

NEC

**MultiSync XG85RP/XG85RPW
MultiSync XG135RP**

**Large Screen MultiSync Rear Projection System
Operation Manual**

**Model Number:
XG-852C/XG-1352C**

CAUTION: To turn off main power, be sure to remove the plug from power outlet. The power outlet socket should be installed as near to the equipment as possible, and should be easily accessible.

3. GSGV Acoustic Noise Information Ordinance:

The sound pressure level is less than 70 dB(A) according to ISO 3744 or ISO 7779.

WARNING

TO PREVENT FIRE OR SHOCK HAZARDS, DO NOT EXPOSE THIS UNIT TO RAIN OR MOISTURE. ALSO DO NOT USE THIS UNIT'S POLARIZED PLUG WITH AN EXTENSION CORD RECEPTACLE OR OTHER OUTLETS, UNLESS THE PRONGS CAN BE FULLY INSERTED. REFRAIN FROM OPENING THE CABINET AS THERE ARE HIGH-VOLTAGE COMPONENTS INSIDE. REFER SERVICING TO QUALIFIED SERVICE PERSONNEL.

AVERTISSEMENT

POUR EVITER UN FEU OU UN RISQUE D'ELECTROCUTION NE PAS EXPOSER CET ENSEMBLE A LA PLUIE OU A L'HUMIDITE; DE MEME, NE PAS BRANCHER LA PRISE POLAIRE AVEC UNE RALLONGE A MOINS QUE LES DENTS DE LA PREMIERE NE S'Y INSERENT PLEINEMENT. EVITER D'OUVRIER LE COFFRET CAR IL Y A, A L'INTERIEUR, DES COMPOSANTS SOUMIS A UNE HAUTE-TENSION; POUR LES REPARATIONS, S'ADRESSER A UN PERSONNEL QUALIFIE.

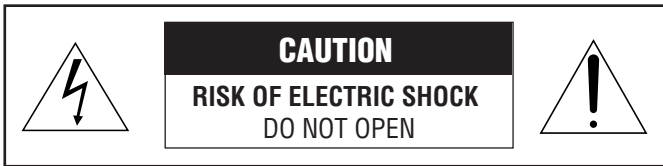



CAUTION: TO REDUCE THE RISK OF ELECTRIC SHOCK, DO NOT OPEN COVER. NO USER-SERVICEABLE PARTS INSIDE. REFER SERVICING TO QUALIFIED SERVICE PERSONNEL.

ATTENTION: POUR EVITER LES RISQUES D'ELECTROCUTION, NE PAS OUVRIR LE COUVERCLE. AUCUN DES ELEMENTS INTERNES NE DOIT ETRE REPARÉ PAR L'UTILISATEUR. NE CONFIER L'ENTRETIEN QU'A UN PERSONNEL QUALIFIE.

 This symbol warns the user that uninsulated voltage within the unit may have sufficient magnitude to cause electric shock. Therefore, it is dangerous to make any kind of contact with any part inside of this unit.

 L'éclair fléché dans un triangle équilatéral est destiné à avertir l'utilisateur de la présence, dans l'appareil, d'une zone non-isolée soumise à une haute-tension dont l'intensité est suffisante pour constituer un risque d'électrocution.

 This symbol alerts the user that important literature concerning the operation and maintenance of this unit has been included. Therefore, it should be read carefully in order to avoid any problems.

 Le point d'exclamation dans un triangle équilatéral est destiné à attirer l'attention de l'utilisateur sur la présence d'informations de fonctionnement et d'entretien importantes dans la brochure d'accompagnement l'appareil.

DOC compliance Notice

This Class A digital apparatus meets all requirements of the Canadian Interference-Causing Equipment Regulations.

DOC avis de conformation

Cet appareil numérique de la classe A respecte toutes les exigences du Règlement sur le Matériel D'interférence du Canada.

WARNING

This equipment has been tested and found to comply with the limits for a Class A digital device, pursuant to Part 15 of the FCC Rules. These limits are designed to provide reasonable protection against harmful interference when the equipment is operated in a commercial environment. This equipment generates, uses, and can radiate radio frequency energy and, if not installed and used in accordance with the installation manual, may cause harmful interference to radio communications. Operation of this equipment in a residential area is likely to cause harmful interference in which case the user will be required to correct the interference at his own expense.

Important Safeguards

The following are important safety instructions designed to ensure the long life of your projector and to prevent fire and shock hazards. Be sure to read these safety instructions carefully and follow all warnings given below.

Installation

The projector must be installed by trained personnel.

Place the projector on a flat, level surface and in a dry area free from dust and moisture. Do not place the projector in direct sunlight, near stoves or other heat radiating appliances. Smoke, steam and exposure to direct sunlight could adversely affect the internal components. Avoid rough handling when moving your equipment as a strong shock could damage its internal components.

Power supply

The XG85RP/XG85RPW and XG135RP projector are designed to operate on 120 V 60 Hz AC power supply. Make sure your local power supply matches these requirements before operation.

Handle the power cord carefully and avoid excessive bending. A damaged cord may cause electric shock or fire. If the projector is not to be used for an extended period, remove the plug from the power outlet.

Cleaning

Always unplug the projector from the wall outlet before cleaning.

Cleaning the cabinet and front panel periodically with a soft cloth. If heavily stained, use a mild detergent solution. Never use strong detergents or solvents such as alcohol or a thinner to clean your projector.

Cleaning the screen

Clean the screen by rubbing lightly with a dry or slightly damp cloth. When the screen becomes dirty or badly or stained, use a mild detergent solution.

NOTE: Never attempt to remove dirt from the grooves by cleaning the grooves individually, as this will damage the screen.

Fire and Shock Precautions

Adequate ventilation must be provided to prevent heat build-up inside the projector. Make sure the ventilation holes are unobstructed.

Keep the inside of the projector free from foreign objects, such as paper clips, nails, paper, etc. Do not attempt to retrieve such objects yourself or insert metal objects such as wire and screw-drivers inside the projector. If a hazardous object falls inside the projector, unplug it immediately and call a qualified electrical repairman for removal. Do not set liquids on top of the projector.

Mesures de sécurité importantes

Les instructions de sécurité importantes ci-dessous ont été conçues pour garantir une longue durée de service du projecteur et éviter les risques d'incendie et de décharge électrique. Lire attentivement ces instructions et suivre les mises en garde indiquées en bas de page.

Installation

Le projecteur doit être installé par un personnel qualifié. Placer le projecteur sur une surface plate, stable et uniforme, dans un endroit sec sans poussière ni humidité. Ne pas placer le projecteur en plein soleil, près de fours ou d'autres appareils émettant de la chaleur. De la fumée, de la vapeur et une exposition en plein soleil pourrait affecter les composants internes. Éviter une manipulation brusque lorsque l'appareil est déplacé, car un choc violent pourrait endommager ses composants internes.

Alimentation

Le projecteur est conçu pour fonctionner sur une source d'alimentation secteur de 120V 60Hz CA. Vérifier que l'alimentation locale correspond à cette tension avant de brancher l'appareil. Manipuler le cordon d'alimentation avec précaution et éviter de trop le courber. Un cordon endommagé peut provoquer une décharge électrique ou un incendie. Si le projecteur ne doit pas être utilisé pendant longtemps, débrancher la fiche de la prise secteur.

Nettoyage

Débrancher le projecteur de la prise d'alimentation avant de le nettoyer. Nettoyer périodiquement le coffret avant avec un chiffon doux. S'ils sont très tachés, utiliser une solution de détergent doux. Ne jamais utiliser de détergents ou solvants puissants comme de l'alcool ou un diluant pour nettoyer le projecteur.

Nettoyage de la lentille: Éviter de toucher les surfaces de la lentille.

Un revêtement spécial a été appliqué sur les surfaces de la lentille.

Consulter votre revendeur pour le nettoyage de la lentille.

Précautions à prendre contre l'incendie et les décharges électriques

Une bonne aération doit être prévue pour éviter l'accumulation de chaleur à l'intérieur du projecteur. Vérifier que les ouvertures d'aération ne sont pas bouchées. Ne laisser pénétrer aucun objet étranger, comme des épingles, des clous, du papier, etc. à l'intérieur du projecteur et ne pas essayer de récupérer soi-même de tels objets en insérant des objets métalliques comme un fil ou un tournevis à l'intérieur du projecteur. Si un objet tombe à l'intérieur du projecteur, débrancher immédiatement celui-ci et appeler un électricien qualifié pour qu'il le retire.

Ne pas poser de liquides sur le projecteur.

LIMITED WARRANTY

NEC Technologies, Inc. (hereafter NECTECH) warrants this product to be free from defects in material and workmanship under the following terms.

HOW LONG IS THE WARRANTY

The chassis parts and labor are warranted for (2) Two Years and cabinet for (1) One Year from the date of the first customer purchase.

WHO IS PROTECTED

This warranty may be enforced only by the first purchaser.

WHAT IS COVERED AND WHAT IS NOT COVERED

Except as specified below, this warranty covers all defects in material or workmanship in this product. The following are not covered by the warranty:

1. Any product which is not distributed in the U.S.A. or Canada, by NECTECH or which is not purchased in the U.S.A. or Canada from an authorized NECTECH dealer.

If you are uncertain as to whether a dealer is authorized, please contact NECTECH at 800-836-0655.

2. Any product on which the serial number has been defaced, modified or removed.
3. Damage, deterioration or malfunction resulting from:
 - a. Accident, misuse, abuse, neglect, fire, water, lightning or other acts of nature, unauthorized product modification, or failure to follow instructions supplied with the product.
 - b. Repair or attempted repair by anyone not authorized by NECTECH.
 - c. Any shipment of the product (claims must be presented to the carrier).
 - d. Removal or installation of the product.
 - e. Any other cause which does not relate to a product defect.
 - f. Burns or residual images upon the phosphor of the tubes.
4. Cartons, carrying cases, batteries, external cabinets, magnetic tapes, or any accessories used in connection with the product.

WHAT WE WILL PAY FOR AND WHAT WE WILL NOT PAY FOR

We will pay labor and material expenses for covered items, but we will not pay for the following:

1. Removal or installation charges.
2. Costs of initial technical adjustments (set-up), including adjustment of user controls. These costs are the responsibility of the NECTECH dealer from whom the product was purchased.
3. Payment of shipping charges.

HOW YOU CAN GET WARRANTY SERVICE

1. To obtain service on your product, consult the dealer from whom you purchased the product, or ship it prepaid to any authorized NECTECH service center.
2. Whenever warranty service is required, the original dated in voice (or a copy) must be presented as proof of warranty coverage, and should be included in any shipment of the product. Please also include in any mailing, your name, address and a description of the problem (s).
3. For the name of the nearest NECTECH authorized service center, call NECTECH at 800-836-0655.

LIMITATION OF IMPLIED WARRANTIES

All implied warranties, including warranties of merchantability and fitness for a particular purpose, are limited in duration to the length of this warranty.

EXCLUSION OF DAMAGES

NECTECH's liability for any defective product is limited to the repair or replacement of the product at our option. NECTECH shall not be liable for:

1. Damage to other property caused by any defects in this product, damages based upon inconvenience, loss of use of the product, loss of time, commercial loss; or
2. Any other damages whether incidental, consequential or otherwise. Some states do not allow limitation on how long an implied warranty lasts and/or do not allow the exclusion or limitation of incidental or consequential damages, so the above limitations and exclusions may not apply to you.

HOW STATE LAW RELATES TO THE WARRANTY

This warranty gives you specific legal rights, and you may also have other rights which vary from state to state.

FOR MORE INFORMATION, TELEPHONE 800-366-5213
NEC TECHNOLOGIES, INC.
1250 N. Arlington Heights Road, Suite 500
Itasca, Illinois 60143-1248

NOTE: All products returned to NECTECH for service MUST have prior approval. To get approval, call NEC Technologies at 800-836-0655.

INTRODUCTION

Before operating this projector, please read this manual carefully and completely. This manual will provide you with the basic instructions for operation of the projector. Installation, preliminary adjustments and procedures which require the opening of the projector and contact with electrical components should be performed by service personnel. For continued safe and reliable operation, use only cables supplied by the manufacturer for power. Adhere to all notes and warnings.

Features

- ▶ Multi scan circuit automatically locks on video, superdata from 15 to 85 kHz (XG85RP/XG85RPW) and graphics signals from and 15 to 135 kHz (XG135RP). You can interface video and high resolution RGB signals from various computers, workstations and graphics boards.
- ▶ 8" CRTs with deflection angle 90 degrees produce a detailed picture with a resolution of 2500×2000 (addressable). (XG85RP/XG85RPW: 1600×1200 dots)
- ▶ Big, beautiful and bright 72" / 66" diagonal screen.
Large 72" (4 : 3 aspect ratio) and 66"(16 : 9 aspect ratio) screen provides a bright and highly realistic color picture produced.

*The XG85RP/XG135RP is a 72" model ; XG85RPW is a 66" model.
- ▶ Newly developed video output circuit makes possible 110 MHz of Video Bandwidth (XG85RP/XG85RPW) and 150MHz (XG135RP) with 1100 lumens peak light output (XG85RP/XG85RPW) and 1200 lumens (XG135RP).
- ▶ ECP lens produces an image with true color reproduction.
- ▶ AKB circuit provides stable white balance.
- ▶ Two 5×19" rack mounts
- ▶ Digital convergence provides high accuracy for projecting fine graphic displays.
- ▶ On-screen menus provide easy access to adjustment items.
- ▶ ISS-6020/ISS-6020G interface allows 100 inputs.
- ▶ Video system compatible with NTSC, PAL, SECAM and NTSC 4.43.
- ▶ Up to 100 sources can be stored in digital memory.
- ▶ Quick copy convergence for fast easy set up from one pre-set signal.
- ▶ Built in self diagnostics for on-sight troubleshooting.
- ▶ Built in test patterns such as "CROSS HAIR", "CROSS HATCH", "DOT", "WINDOW", "ALL WHITE", "GRAY SCALE", and "H (FOCUS)" for accurate setup.
- ▶ Source information status display.
- ▶ The SEQUENCER function allows the projector to automatically select input signals one after another as programmed by the user.
- ▶ Gamma Correction for improved Gray Scale and improved Gray Scale Tracking.

CONTENTS

PART NAMES AND FUNCTIONS	8
Rear Panel	9
Front Panel	9
Remote Control Unit	10
Battery installation and replacement	11
Remote control cautions	11
Handling remote control and batteries	11
EXAMPLES OF CONNECTIONS	12
Cautions on Connections	12
When Used in Stand Alone Operation	12
When Used with One Switcher (ISS-6020/ISS-6020G)	13
When Used with Two or More Switchers (100 Inputs)	14
REMOTE 1 Terminal	16
BASIC OPERATION	18
Picture Projection	18
Displaying the Menu and Adjustment Screens	19
Storing Projector Settings (Automatic Save Feature)	20
Picture Adjustment	22
Position Adjustment	23
Sound Adjustment	25
Input Selection	27
Source Information	29
Static Convergence Adjustment	30
Closed Caption Mode Selection	31
Setting Timer	32
Mute	36
Normal, Load, and Cancel Function	36
Data Area for Output and Storage	37
Searching Registered Signals	38
Screen Format in Projecting a Picture	39
SPECIFICATIONS	40
Cabinet Dimensions	41

This manual covers the XG85RP, XG85RPW and XG135RP projectors.
The operating procedures are common to the three models.

PART NAMES AND FUNCTIONS

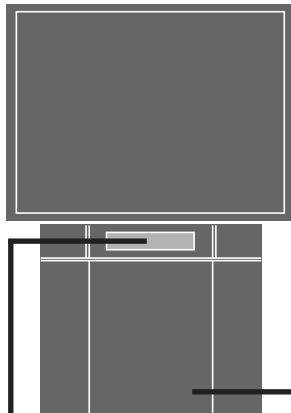

Rear

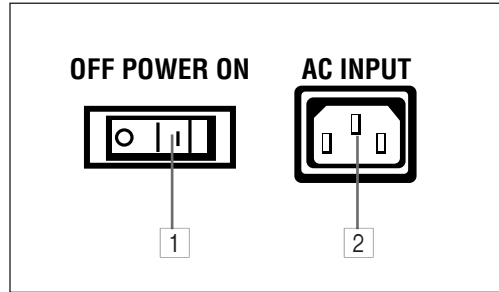

Open the front access cover to access the terminal panel.
To remove the front access cover, grasp at top and bottom, and pull with quick firm pressure.

Front

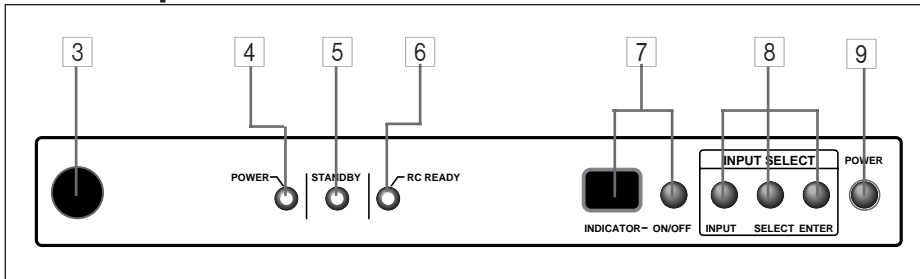

Terminal Panel

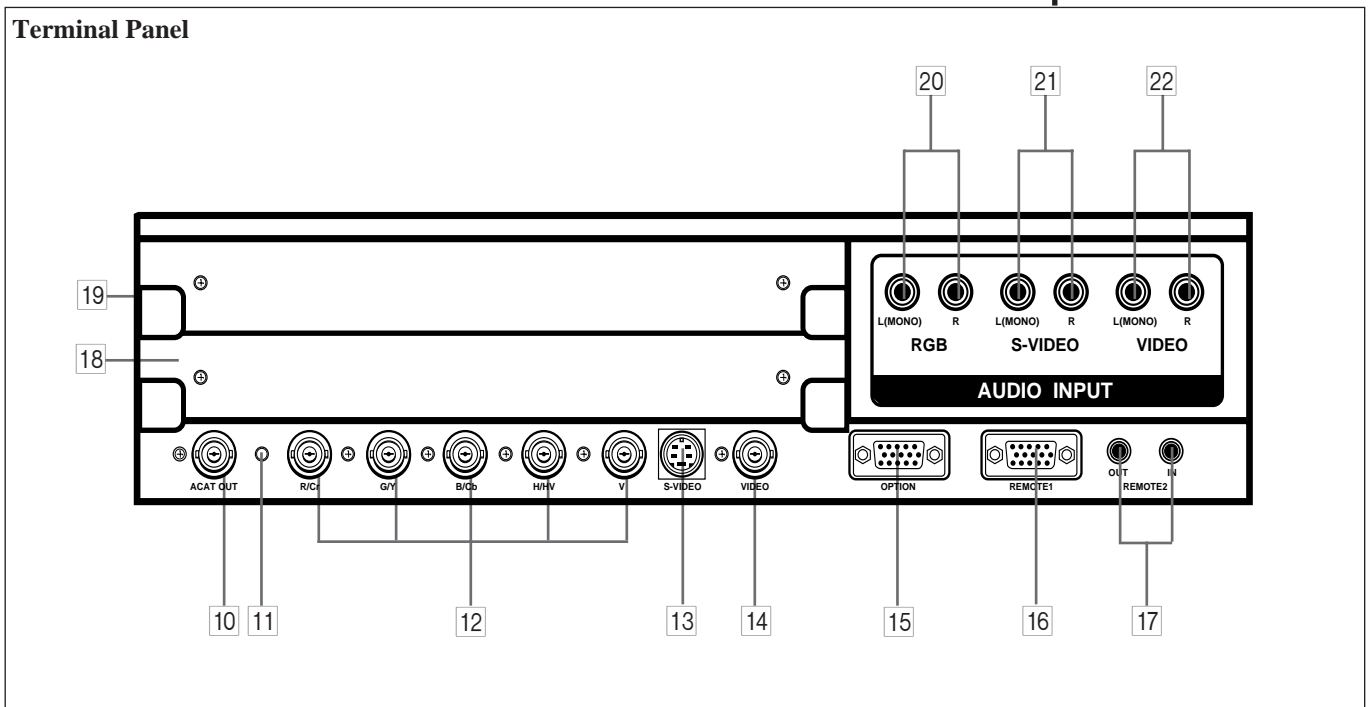

Rear Panel

1 Power Switch (Main power)

To turn on the main power to the projector press the switch to the ON position (I). The STANDBY and the RC READY indicator will light.

In this condition you can start up the projector by pressing the POWER ON button on the remote control or the POWER button on the rear panel.

Press to the OFF position (O) to turn the main power off.

NOTE: When turning off the main power, first return the projector to the standby condition by pressing the POWER OFF button on the remote control or the POWER button on the rear panel and then turn off the main POWER switch. These procedures are necessary to protect your projector and the connected equipment.

2 AC INPUT

Connect the supplied power cord here.

Front Panel

3 Remote Sensor

Receives the signal from the supplied remote control when used in the wireless mode.

4 POWER Indicator

Lights up when the projector is turned on.

5 STANDBY Indicator

Lights up when the projector's main POWER switch is on. Flashes when the projector is not connected with the Switcher correctly or when the Switcher is turned off.

6 RC READY Indicator

Lights up when the projector's main POWER switch is on. Flashes when the projector receives a signal from the remote control.

7 Two Digit Display INDICATOR:

Displays projector error codes. ("00" in normal operation)

ON/OFF Switch:

Turns the INDICATOR on or off.

8 INPUT SELECT Buttons

INPUT: press to display the INPUT SELECT screen.

SELECT: press to select an input by highlighting the input terminal.

ENTER: press to execute selection and to switch input.

9 POWER Button

Turns the projector on or off when the projector is in the standby condition (Main Power switch must be on and the STANDBY and the RC READY indicator lit).

10 ACAT OUT Terminal

This is a video output connector for the optional built in CCD camera. The CCD camera is needed in order to perform automatic convergence with the optional ACAT software.

11 Active Indicator (green LED)

Lights up when the INPUT A slot is selected.

12 R/Cr,G/Y, B/Cb, H H/V and V Input Terminals (INPUT A)

Connect R,G,B,H (Horizontal sync) and V (Vertical sync) outputs of the external equipment (such as the Switcher). If using a component with a combined sync (SYNC) output, connect it to the H/V terminal. When using luminance and color-difference signals of HDTV and DVD, connect a Pr/Cr to the R, a Y to the G and a Pb/Cb to the B input of the projector.

13 S-VIDEO Input Terminal (INPUT A)

Connect to the S-video output of the external equipment such as a VCR with an S-video output. This terminal allows switching between S2 and S1 VIDEO input modes.

14 VIDEO Input Terminal (INPUT A)

Connect to the video output of the external equipment such as a VCR or laser disk player.

15 OPTION Terminal

For system expansion such as PC-control.

16 REMOTE 1 Terminal

This terminal allows external control of the projector from either the Switcher or from an external control. When the Switcher is used, connect to the REMOTE 1 terminal on the back of the Switcher.

NOTE: The ISS-6020/ISS-6020G Switcher is compatible with this projector.

17 REMOTE 2 Terminal

IN: for the supplied service remote control.

OUT: connect to a second projector's IN terminal to relay the input at the IN terminal.

NOTE: The wireless control does not work when the plug of the supplied remote cable is inserted into the REMOTE 2 IN terminal.

18 INPUT B

Slot for adding optional RGB or video input cards.

19 INPUT C

Slot for adding optional RGB or video input cards.

NOTE: The optional RGB INPUT and VIDEO INPUT modules can be installed in the INPUT B and INPUT C slots.

20 RGB Audio Input Terminals (L/R)

Connect to the audio outputs of the external equipment such as ISS-6020/6020G or a PC.

21 S-VIDEO Audio Input Terminals (L/R)

Connect to the S-video audio outputs of the external equipment such as a VCR with S-video outputs.

22 VIDEO Audio Input Terminals (L/R)

Connect to the audio outputs of the external equipment such as a VCR.

PART NAMES AND FUNCTIONS

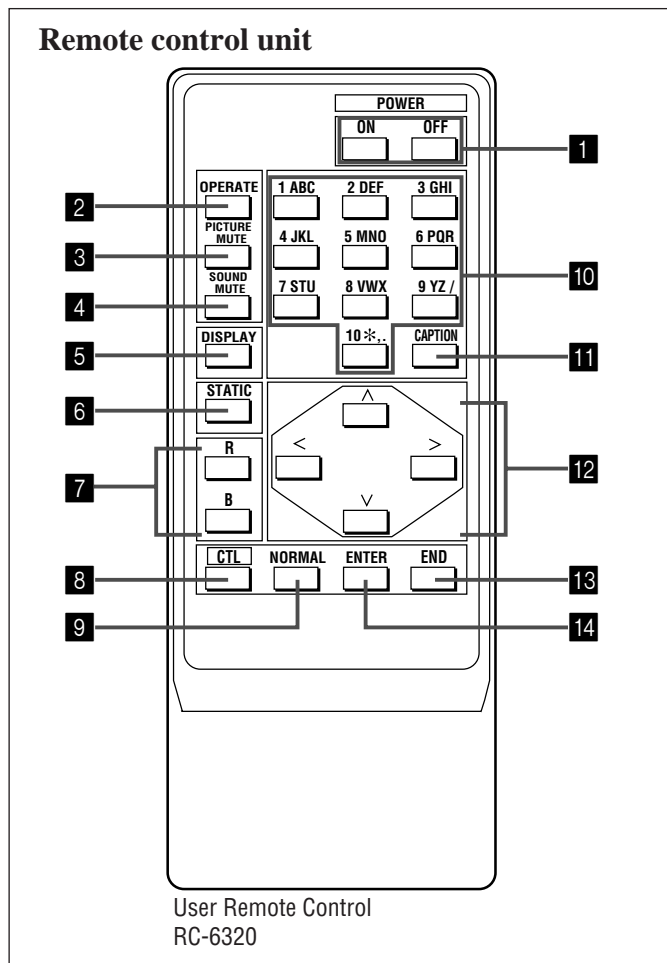

NOTE: The full function remote control is designed for setup adjustment. Use the user remote control for normal operation.

1 POWER Buttons (ON/OFF)

Press the ON button to turn the projector on when the projector is in the standby condition (STANDBY and RC READY indicators lit). Press the OFF button to return the projector to the standby condition.

2 OPERATE Button

Press to display the "OPERATE" menu.

3 PICTURE MUTE Button

Press to mute the picture. Press again to display the picture. You can also mute the picture by holding down CTL and pressing PICTURE MUTE buttons. To restore the picture, holding down CTL and press PICTURE MUTE again. Or simply press END.

NOTE: When the picture is muted by using CTL and PICTURE MUTE buttons, even if an input is switched to another or the power is turned off using the remote POWER OFF button, the mute cannot be canceled. Turning off the main power will cancel the mute.

4 SOUND MUTE Button

Press to mute the sound. Press again to return the sound.

5 DISPLAY Button

Press to turn on or off the on-screen display. Pressing with CTL eliminates the on-screen display; pressing with CTL again restores it.

NOTE: Even if the on-screen display may be turned off with pressing CTL and DISPLAY, any adjustment will still change the projector's memory settings. This mode is available even when an input is switched to another or the power is turned off using the POWER OFF button on the remote control. On-screen display mute function can be canceled by turning off the main power.

6 STATIC Button

Press to enter the STATIC mode. You can adjust the static convergence.

7 R and B Buttons

Turn each CRT beam on and off separately. When using with the CTL button, you can select the CRT to be adjusted during static convergence.

8 CTL Button

Used in conjunction with other buttons, similar to a shift key on a computer.

9 NORMAL Button

Returns the standard level for each signal. When pressed once, the confirmation message will be displayed. When "YES" is selected and ENTER is pressed, the data will be returned to the standard level. While holding down the CTL button, press the NORMAL button to display the "LOAD/CANCEL" menu to select either LOAD (last stored level) or CANCEL (data cancelled).

10 INPUT Buttons

Select menu and switches input signals.

11 CAPTION Button

Press to display the CLOSED CAPTION menu.

12 CURSOR Buttons

Used for increasing and decreasing control levels, cursor movement and convergence adjustments.

13 END Button

Ends the adjustment mode.

14 ENTER Button

Executes menu selection and switches to selected input.

Battery installation and replacement

User remote control (RC-6320)

1 Press down on the battery compartment cover and slide the cover in the direction of the arrow.

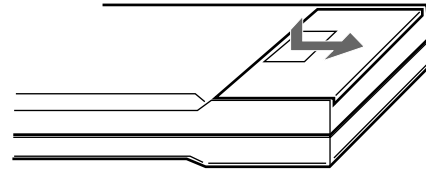

2 Install the two new batteries, making sure that their polarity matches the \oplus \ominus diagrams inside the battery compartment. Incorrect polarity could damage the unit.

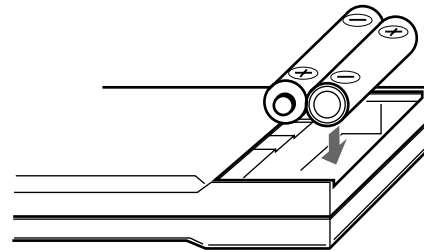

3 Close the battery compartment cover.

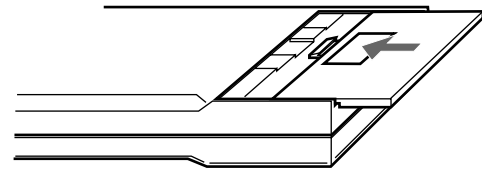

NOTE: The remote control is powered by two alkaline 1.5V AA batteries.

Remote control cautions

Use the remote control within a distance of about 7m (23 ft.) and at 30 degrees angle left and right.

Handling remote control and batteries

- Do not drop or mishandle the remote.
- Do not get the remote wet. If the remote gets wet, wipe it dry immediately.
- Avoid heat and humidity.
- When not using the remote for a long period, remove the batteries.
- Do not use new and old batteries together, or use different types together.
- Do not take apart the batteries, heat them, or throw them into a fire.

EXAMPLES OF CONNECTIONS

CAUTIONS ON CONNECTIONS:

- Unplug the projector and other equipment from the AC supply before making connections.
- Make sure that the plug of the power cord is properly connected to the power outlet. A loose connection may cause hum or noise.
- Confirm your connection layout with the user's manual accompanying the equipment to be connected with the ISS-6020/ISS-6020G Switcher.

When Used in Stand Alone Operation

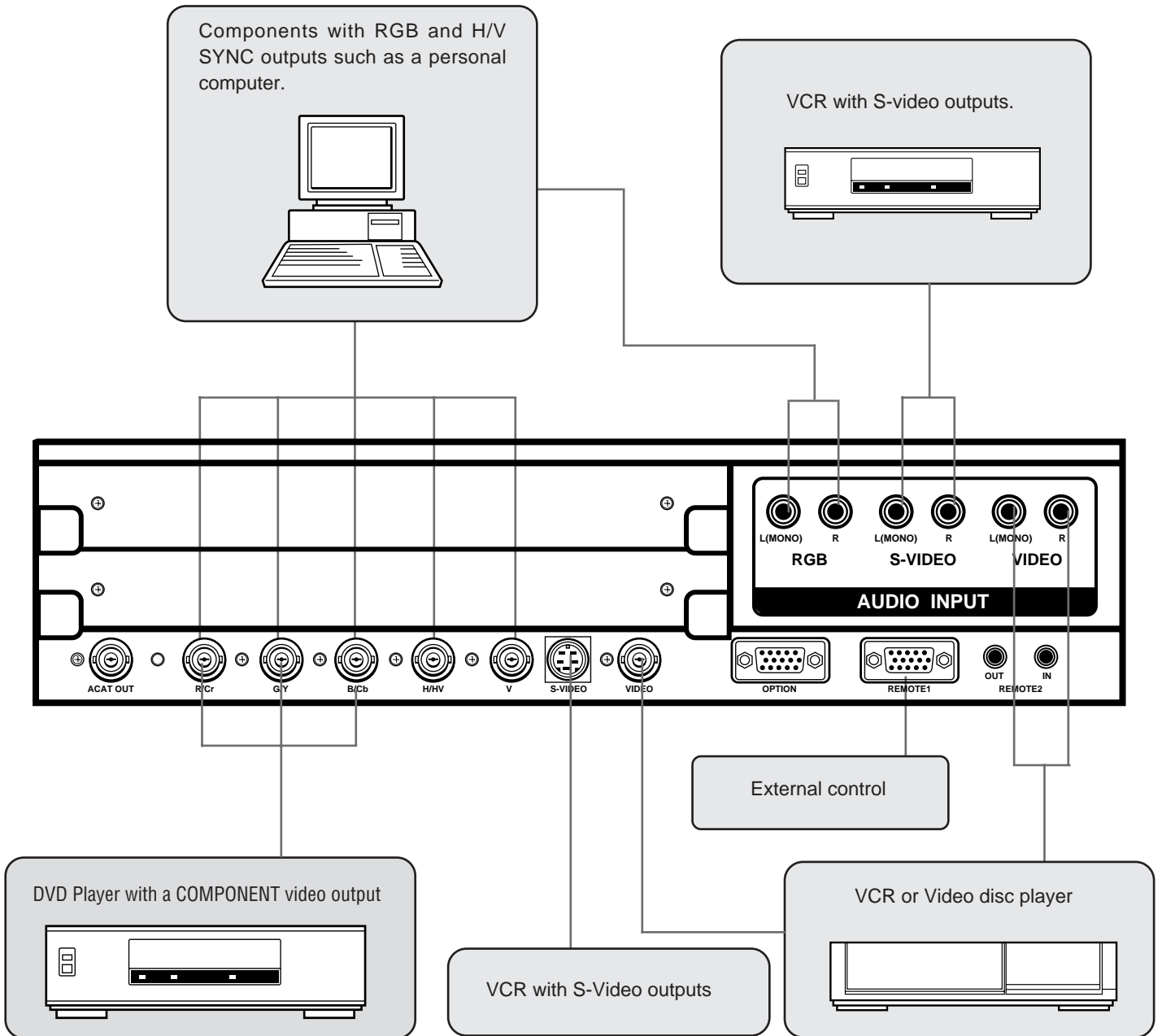

- Make sure that the STANDALONE mode is selected from the CONNECT CONDITION menu. See the Set-up manual for connecting the Switcher.

When Used with One Switcher (ISS-6020/ISS-6020G)

Up to 10 input signals can be accepted when the projector is connected to one Switcher. Using the projector with the Switcher allows easy adjustment and signal selection.

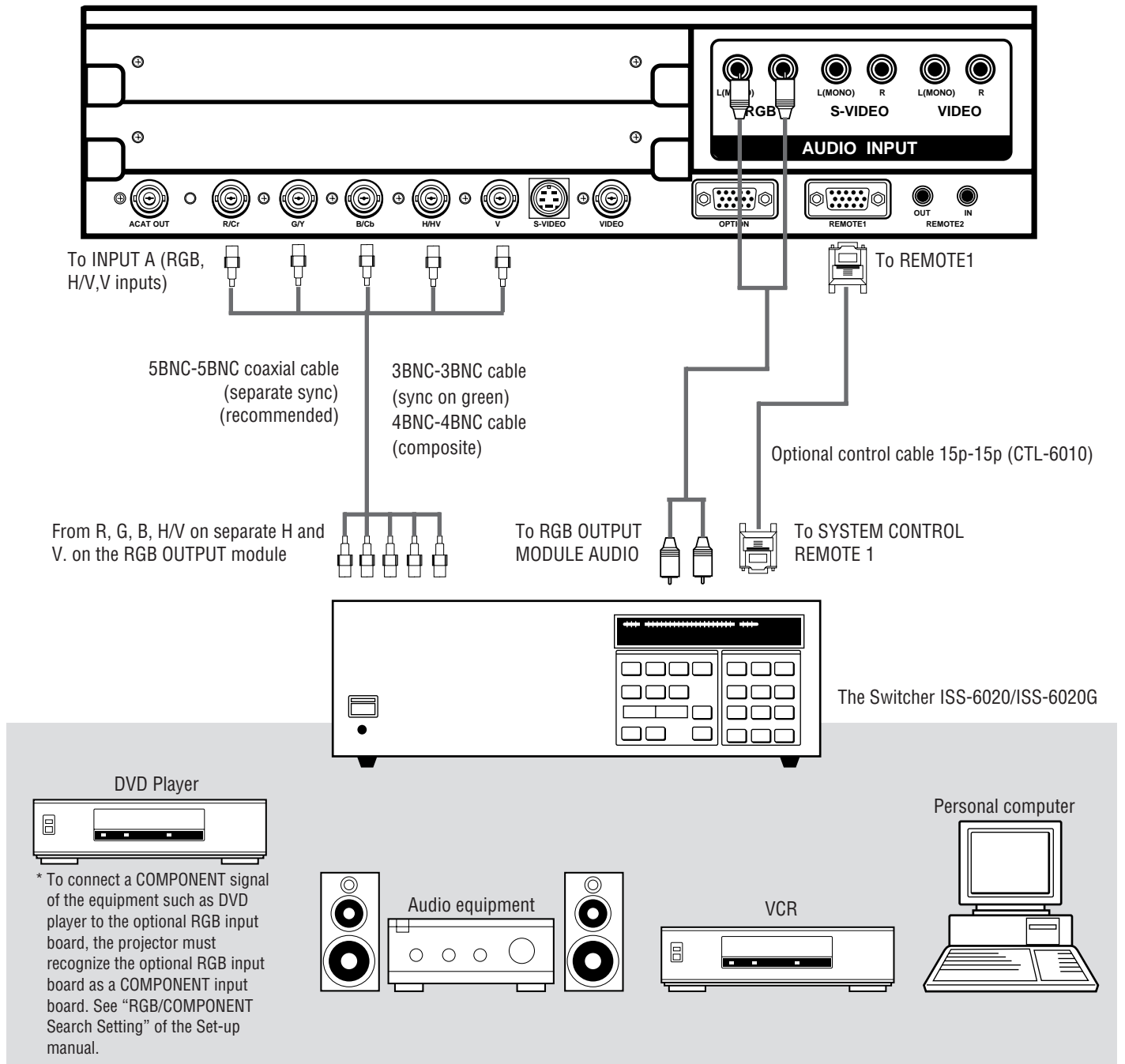

- Make sure that the SW1 LEVEL mode is selected from the CONNECT CONDITION menu. See the Set-up manual for the information in detail.
- For more information on the Switcher, refer to the user's manual accompanying the ISS-6020/ISS-6020G Switcher.
- All cables mentioned above are optional.

EXAMPLES OF CONNECTIONS

When Used with Two or More Switchers (100 Inputs)

Up to 100 inputs can be accepted using the Switcher.

How to make connections:

- ① Connect the REMOTE 1 terminal of the master Switcher to the REMOTE 1 of the projector using the optional control cable (15p-15p/CTL-6010).
- ② Next connect the REMOTE 2 terminal of the master Switcher to the REMOTE 1 terminal of the first slave Switcher using the same optional control cable as mentioned above. Third, connect the REMOTE 2 terminal of the first slave to the REMOTE 1 of the second slave, and the REMOTE 2 terminal of the second slave to the REMOTE 1 terminal of the third slave (— and the REMOTE 2 of the ninth slave to the REMOTE 1 of the tenth slave). Connect all the Switchers with optional control cables.

NOTE:

- Be sure to set all the slide switches (S8603) of the Switcher to RS-422 positions. Set the one on the last slave Switcher to the appropriate position to match the connected equipment such as a personal computer. (RS-422/RS-232C for PC control of projector)
- Set the DIP switch S8601 of the Switcher.

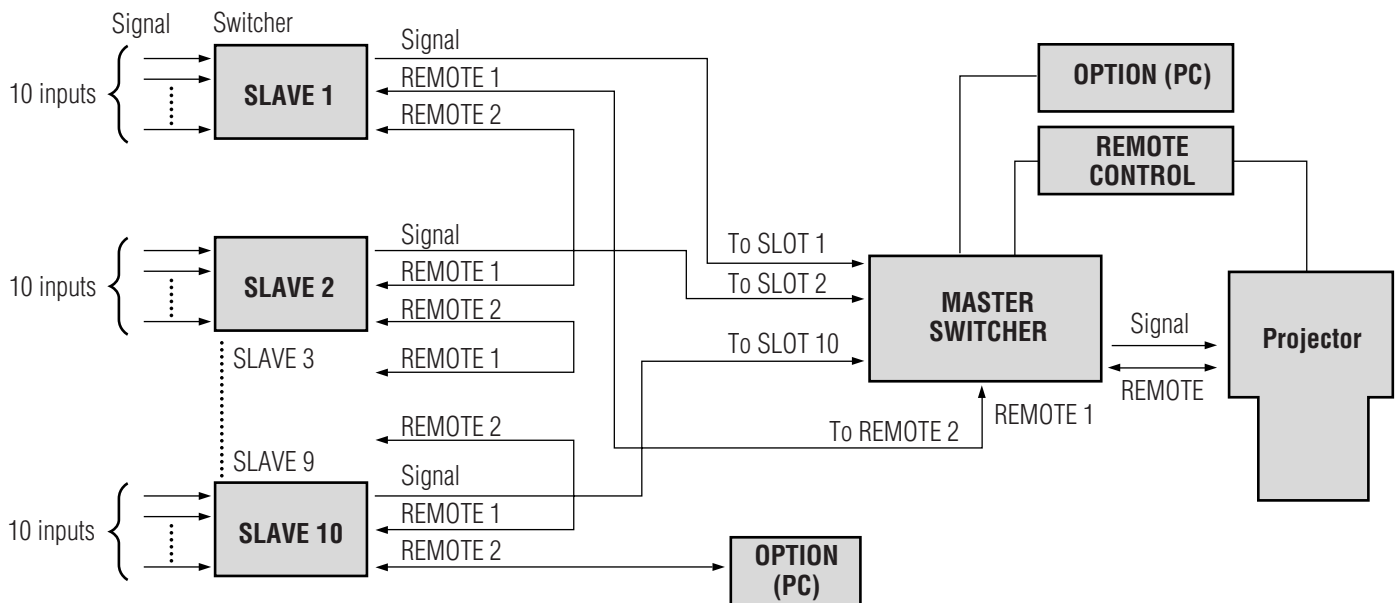

- Make sure that the SW2 LEVEL mode is selected from the CONNECT CONDITION menu. See the Set-up manual for the information in detail.
- Refer to the user's manual accompanying the Switcher.
- Cables mentioned are not included with the projector.

Set the DIP switch (S8601) of the Switcher as follows:

NOTE: Slave numbers 1 to 10 must correspond to the master's slot numbers 1 to 10.

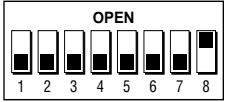
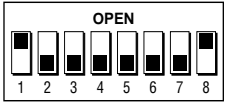
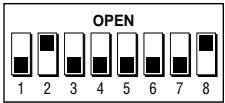
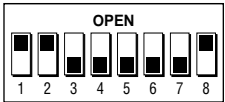
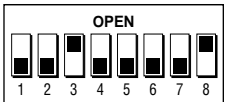
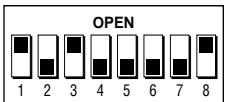
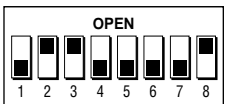
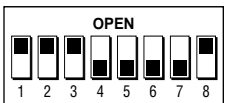
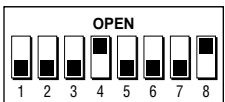
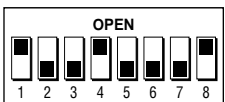
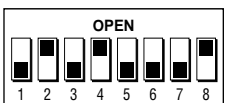
ISS-6020 ISS-6020G	Output to	Setting of S8601
Master	The Projector	
Slave 1	Slot 1 of the Master	
Slave 2	Slot 2 of the Master	
Slave 3	Slot 3 of the Master	
Slave 4	Slot 4 of the Master	
Slave 5	Slot 5 of the Master	
Slave 6	Slot 6 of the Master	
Slave 7	Slot 7 of the Master	
Slave 8	Slot 8 of the Master	
Slave 9	Slot 9 of the Master	
Slave 10	Slot 10 of the Master	

EXAMPLES OF CONNECTIONS

REMOTE 1 Terminal

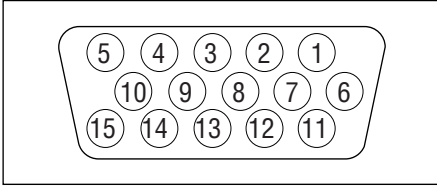

This terminal is used for either connecting the ISS-6020/ISS-6020G Switcher or a third party external control device. When the Switcher is used, connect it with the optional control cable (15-15 pin; 50 ft./16m; CTL-6010) to this terminal.

When used with the Switcher.

Pin No.	FUNCTION
1, 2, 6 and 7	Sending and receiving data when the Switcher is used.
9	Identifying the Projector
15	Ground
Others	Used inside the Projector. Normally set to OPEN.

When using with the Switcher ISS-6020/ISS-6020G, connect no. 1,2,6,7,9 and 15 pins of the projector to the same no. pins of the switcher as shown below.

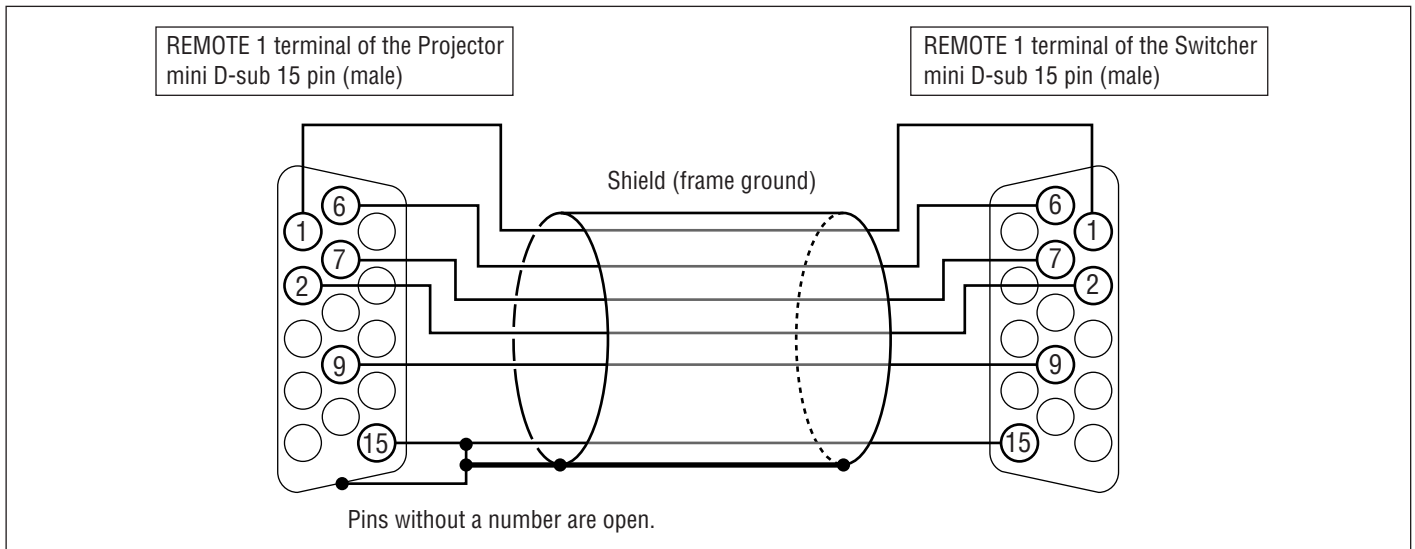

Pin Configuration of Optional CTL-6010 Cable

When used in stand alone operation.

Pin No.	SHORT/OPEN			FUNCTION	
14	SHORT OPEN			External control mode ON External control mode OFF	
5	SHORT OPEN			POWER ON POWER OFF	
10	SHORT OPEN			PICTURE MUTE ON PICTURE MUTE OFF	
4,8, and 12	12	8	4		
	OPEN	OPEN	OPEN	INPUT A	RGB*1
	OPEN	OPEN	SHORT	INPUT A	VIDEO
	OPEN	SHORT	OPEN	INPUT A	S-VIDEO
	OPEN	SHORT	SHORT	INPUT A	COMPONENT
	SHORT	OPEN	OPEN	INPUT B	*2
	SHORT	OPEN	SHORT	INPUT B	*3
	SHORT	SHORT	OPEN	INPUT C	*2
	SHORT	SHORT	SHORT	INPUT C	*3

*1 Some settings allow you to retrieve a COMPONENT signal automatically. See “RGB/COMPONENT Search Setting” of the Set-up manual.

*2 When the optional RGB input board is installed and the RGB input is set, an RGB signal will be selected; when the RGB input board is installed and the COMPONENT input is set, a COMPONENT signal will be selected; when the optional RGB input board is installed and the VIDEO input is set, a VIDEO signal will be selected.

When the optional VIDEO input board is installed, a VIDEO signal will be selected.

*3 An S-VIDEO signal will be selected when :

1. the optional RGB input board is installed and the VIDEO input is set.
2. the optional VIDEO input board is installed.

The term “SHORT” means to connect with pin 15

- When in the external control mode, the POWER, INPUT and PICTURE MUTE buttons on the remote control will not function.

NOTE: Pin 13 is the external remote signal terminal. The projector can be controlled by the same format signal as the supplied remote control from the external controller regardless of setting Pin 14.

NOTE: When turning the power on using the external control, short Pin 5 about three seconds after supplying the AC power to the projector; when turning the power off using the external control, power off the AC supply to the projector about three seconds after opening Pin 5. These procedures are to protect your projector and the connected equipment.

BASIC OPERATION

Picture Projection

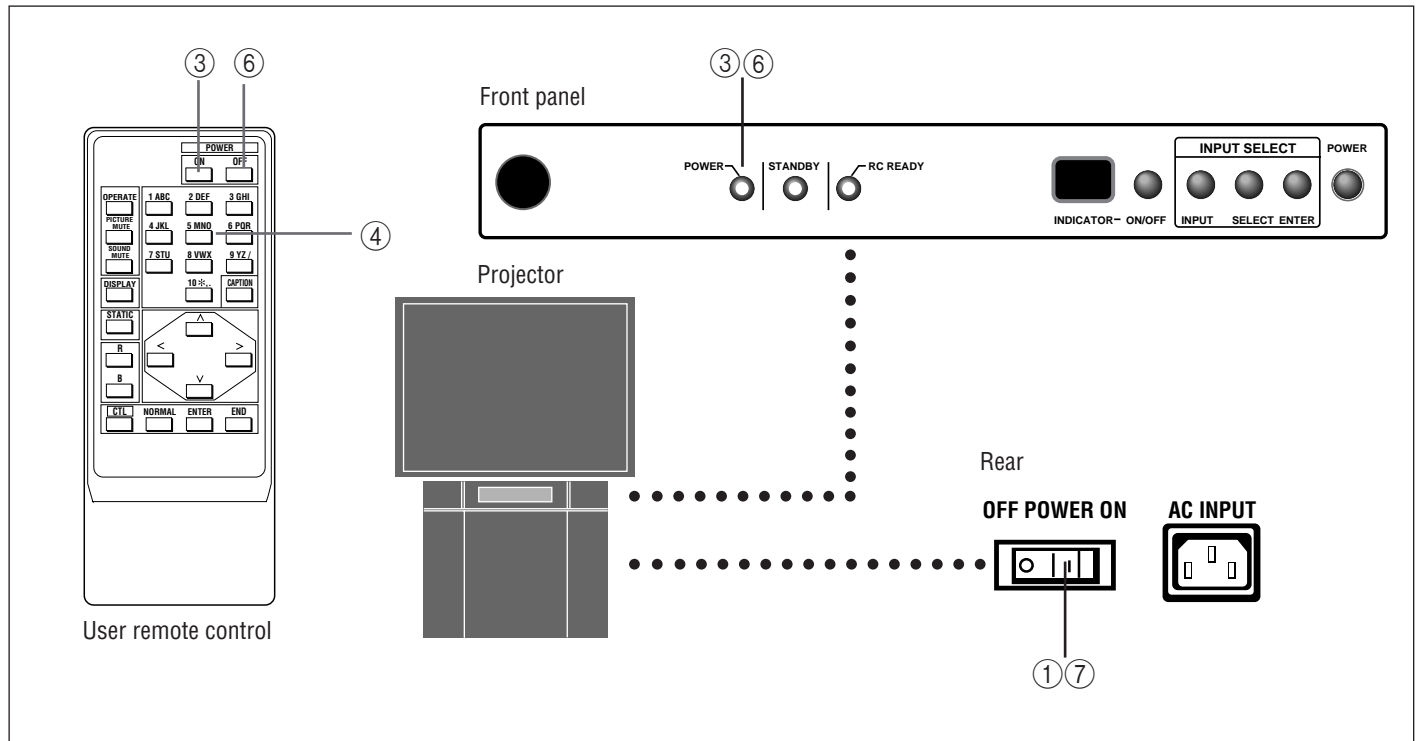

To project a picture source, proceed as follows:

- ① Turn on the main power of the projector.
 - Press the POWER switch on the rear to the ON position (I).
- ② Turn on the power of the connected equipment.
- ③ Turn on the power of the projector.
 - Press the POWER ON button on the remote control or the POWER button on the front panel.
- ④ Select an input signal source by pressing one of the ten INPUT buttons on the remote control. You can also select a signal from the “INPUT SELECT” list.
 - See “INPUT SELECTION” on page 27 for more details.
- ⑤ Adjust the picture and sound.
 - See pages 22 through 26 for more details.
- ⑥ To turn off the power, press the POWER OFF button on the remote control or the POWER button on the front panel.
- ⑦ Press the POWER switch on the front panel to the OFF position (O) to turn off the main power of the projector.
- ⑧ Last, turn off the connected equipment power.

Displaying the Menu and Adjustment Screens

You can easily access your desired screen by selecting menus.

Depending upon button selection, your desired screen will be displayed as shown below:

OPERATE menu

NOTE: Some function items will not be used depending on the input signal or peripheral equipment connected.

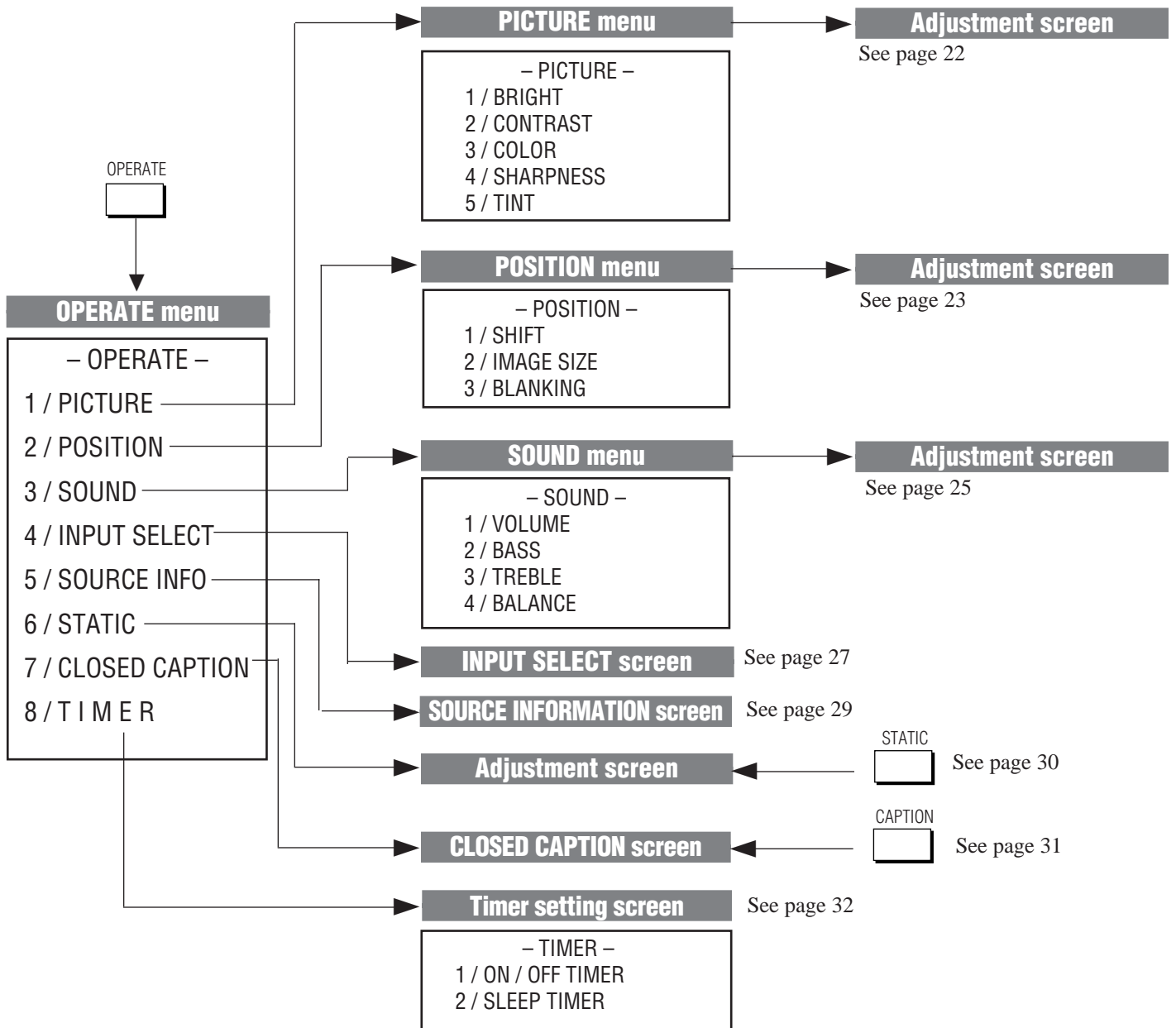

CAUTION: Do not display a bright and still picture for longer than 20 minutes. This could damage the CRTs.

NOTE: The explanation of the operation on the following pages is for use with the remote control.

Storing Projector Settings (Automatic Save Feature)

You have two options to store projector settings in the memory: automatically and manually.

NOTE:

Storing time is four seconds.

- The Automatic Save Feature mode has been set to **DISABLE** by factory. For information on setting, see “Automatic Save Feature” in the Set-Up manual.

■ When the Automatic Save Feature mode is set to “**ENABLE**”, projector settings will be stored in the projector’s memory automatically.



Settings are stored automatically when any one of the following procedures is performed:

- The **END** button is pressed several times to return the adjustment screen to the source screen.
- One input is switched to another.
- The projector is turned off.
- After every 10 minutes of elapsed time.

■ When the Automatic Save Feature mode is set to “**DISABLE**”, projector settings can be stored in the projector’s memory manually.

When you try to return the source screen by pressing **END** several times, the “**STORE ?**” menu is displayed.

To manually save settings, proceed as follows:

1. Use the **END** button to display the “**STORE**” menu from the current adjustment screen or menu.
2. Use the **CURSOR**  or  button to highlight “**CURRENT**”, “**NEW**”, or “**CANCEL**” and press **ENTER**.



Items to select

- **CURRENT** ----- Overwrites the currently projected signal and saves the settings. **NOTE:** An unregistered signal cannot be stored under the "CURRENT" settings.
- **NEW** ----- Starting at memory location No.51, this function saves an unregistered signal as a new signal in memory.
- **CANCEL** ----- Does not save settings.

■ When selecting “NEW”

The current settings are registered as a new signal and are saved to an unassigned line starting at memory location No.51.

A registered name is automatically given.

The “NEW ENTRY?” menu will be displayed.

Use the CURSOR or button to highlight “YES” or “NO” and press ENTER.



Items to select

- YES ----- Registers settings as a new signal and saves the signal in an unassigned location starting at memory location No.51.
- NO ----- Does not register settings.

A registered name is given as follows:

VIDEO/S-VIDEO ----- Video standard with a list number e.g. NTSC51 or PAL52.
 RGB ----- ”RGB” with a list number e.g. RGB60.

NOTE:





- If the Input list does not have any unassigned memory location starting at No. 51 then, the “NEW” item will be selectable. For signal registration see “SIGNAL ENTRY” in the Set-Up manual.
- The Automatic Save Feature is available only for signals listed in the INPUT LIST.

BASIC OPERATION

Picture Adjustment

To adjust the picture for each input, proceed as follows:





NOTE: The color, sharpness, and tint controls are not selected in the "PICTURE" menu for RGB signal. The tint control is not selected in the "PICTURE" menu for SECAM/PAL signal.

- ① Press the OPERATE button.
 - The "OPERATE" menu is displayed.
- ② Use the CURSOR  or  button to highlight the "1/PICTURE" line and press ENTER to display the "PICTURE" menu. You can also select the "PICTURE" menu directly by pressing the INPUT "1" button.
- ③ Use the CURSOR  or  button to select a picture function and then press ENTER. You can also select an item directly by pressing the corresponding number button.
 - The picture adjustment screen will be displayed.

Items to select:

- BRIGHT (Brightness control)
- CONTRAST (Contrast control)
- COLOR (Color intensity control)
- SHARPNESS (Picture detail control)
- TINT (Red and green values control)

NOTE: When you are in the BRIGHT adjustment mode, all the CRTs will be in use. The CRT beam cannot be cut-off.

- ④ Use the CURSOR buttons to adjust a picture to your preference.
 - The CURSOR  or  button increases the level.
 - The CURSOR  or  button decreases the level.
- ⑤ To end this adjustment, press the END button.
 - Wherever the END button is pressed, the screen changes in this order:
"PICTURE" menu → "OPERATE" menu → Source screen

```
  - OPERATE -  
  1 / PICTURE  
  2 / POSITION  
  3 / SOUND  
  4 / INPUT SELECT  
  5 / SOURCE INFO  
  6 / STATIC  
  7 / CLOSED CAPTION  
  8 / T I M E R
```

```
  - PICTURE -  
  1 / BRIGHT  
  2 / CONTRAST  
  3 / COLOR  
  4 / SHARPNESS  
  5 / TINT
```

PICTURE





- BRIGHT -

.....▼..... 60%

Position Adjustment

Adjust the position(SHIFT), the size (IMAGE SIZE) and the screen area (BLANKING).

Proceed as follows:

- ① Press the OPERATE button.
 - The “OPERATE” menu is displayed.
- ② Use the CURSOR  or  button to highlight the “2/POSITION” line and press ENTER to display the “POSITION” menu. You can also select the “POSITION” menu directly by pressing the INPUT “2” button.
- ③ Use the CURSOR  or  button to select either “SHIFT”, “IMAGE SIZE”, or “BLANKING” and then press ENTER. You can also select each item directly by pressing the INPUT “1”, “2” or “3” button.
 - The selected adjustment screen will be displayed.

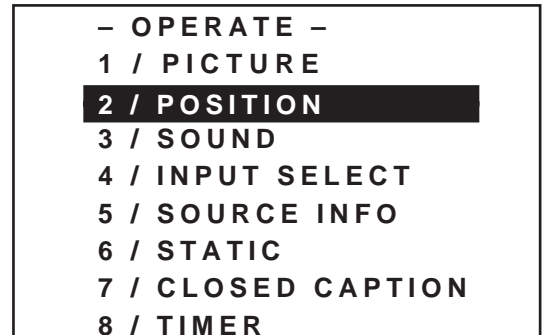





Items to select

- SHIFT (Position of the picture)
- IMAGE SIZE (Picture size)
- BLANKING(Screen area)

- ④ Adjust the position, size, or screen area.

When selecting SHIFT:

Use the CURSOR buttons to move the position of the picture.

- Pressing  or  moves the picture left or right.
- Pressing  or  moves the picture up or down.

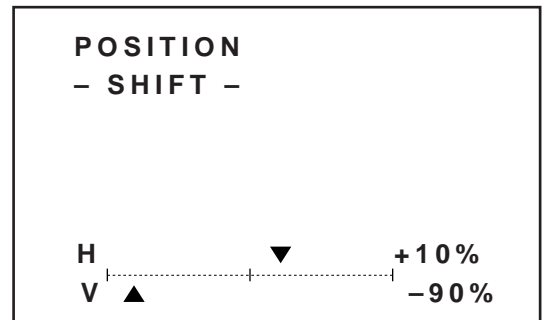

You can also finely adjust the shift .

To do so:

While displaying the SHIFT screen, press and hold CTL and press any one of the CURSOR buttons to display the SHIFT FINE screen.

Pressing  or  moves the picture left or right finely.

Pressing  or  moves the picture up or down finely.



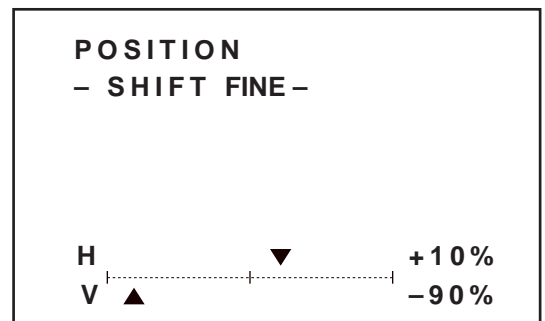

To return to the SHIFT screen, press and hold CTL, then press any one of the CURSOR buttons.



BASIC OPERATION

When selecting IMAGE SIZE:

Use the CURSOR buttons to adjust the size of image.



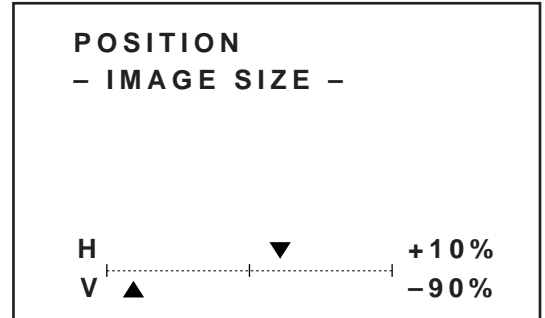

- Pressing  or  button increases or decreases the horizontal size.
- Pressing  or  button increases or decreases the vertical size.







When selecting BLANKING:

- 1) Hold down the CTL button and press CURSOR buttons to choose the right, left, top, or bottom edge.
 - The marker on the selected side will turn to a solid color.

- 2) Adjust the blanking using the CURSOR buttons.

Top and Right Pressing  or  increases the adjustment values.
Pressing  or  decreases the adjustment values.



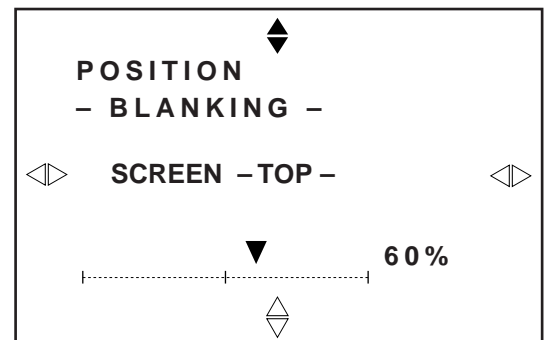

Bottom and Left Pressing  or  increases the adjustment values.
Pressing  or  decreases the adjustment values.

- ⑤ To end this adjustment, press the END button.
 - Whenever the END button is pressed, the screen changes in this order:
"POSITION" menu → "OPERATE" menu → Source screen







Sound Adjustment

Adjust the sound functions to your preference.
Proceed as follows:

- ① Press the OPERATE button.
 - The “OPERATE” menu is displayed.
- ② Use the CURSOR  or  button to highlight the “3/SOUND” line and press ENTER to display the “SOUND” menu. You can also select the “SOUND” menu directly by pressing the INPUT “3” button.
- ③ Use the CURSOR  or  button to select a sound function and press ENTER. You can also select an item directly by pressing the corresponding number button.
 - The sound adjustment screen will be displayed.

Items to select

- VOLUME
- BASS
- TREBLE
- BALANCE



- ④ Use the CURSOR button to adjust sound controls.
 - The CURSOR  or  button increases the level.
 - The CURSOR  or  button decreases the level.



When using the projector in stand alone:

This feature adjusts the speaker volume of the projector.

When using the projector with the switcher:

This feature adjusts the speaker volume of the projector.



The CURSOR  or  button increases or decreases the main speaker volume of the projector (M).

The CURSOR  or  button increases or decreases the sound level of the switcher (S).

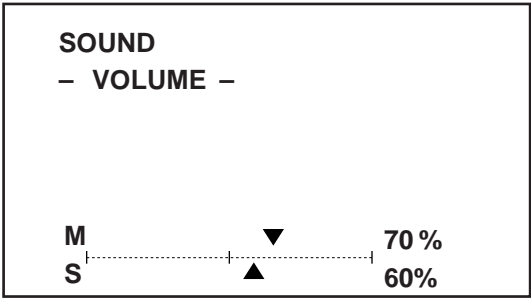
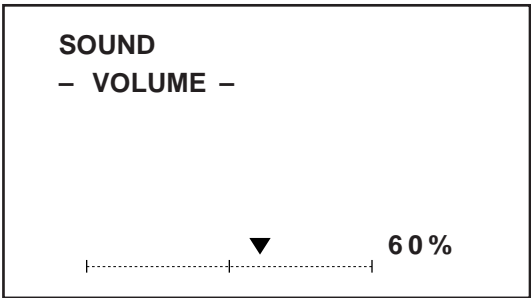
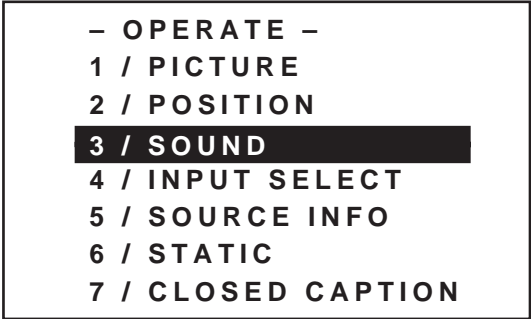
M ----- sound level for the projector
 S ----- sound level for the switcher







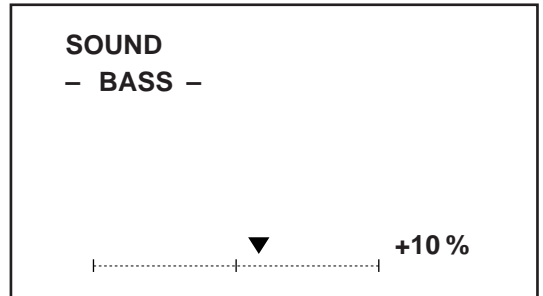
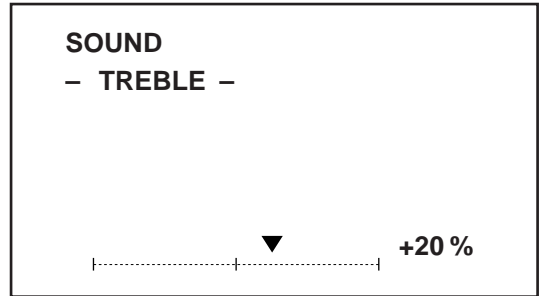
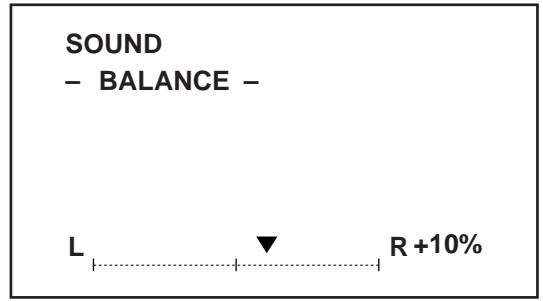

BASIC OPERATION



- ⑤ To end this adjustment, press the END button.
- Whenever the END button is pressed, the screen changes in this order:
“SOUND” menu → “OPERATE” menu → Source screen.
 - The VOLUME function is effective for each input in stand alone mode. (The adjustments are stored in memory.)
 - The VOLUME function (M and S) is effective for each input when connected with the switcher. (The adjustments are stored in memory.)
 - The BALANCE, TREBLE, and BASS are effective for each input respectively.
 - When no menu is selected with the “OPERATE” and “ADJUST” menu, the CURSOR  or  button works as VOLUME (M), but not as VOLUME (S).



Input Selection

You can switch from one input to any other input signal.
Proceed as follows:

- ① Press the OPERATE button.
 - The “OPERATE” menu is displayed.
- ② Use the CURSOR  or  button to highlight the “4/INPUT SELECT” line and press ENTER to display the “INPUT SELECT” list. You can also select the “INPUT SELECT” list directly by pressing the INPUT “4” button.
- ③ Use the CURSOR  or  button to highlight the signal to be switched to and press ENTER to switch to the selected input signal.
Press the  or  button to change the sheet.

NOTE: To advance to the next page or to the previous page, hold down the CTL button then press the CURSOR  or  button. To directly access the page, hold down the CTL button then any one of the INPUT buttons.

- ④ To end the INPUT SELECT list, press the END button.
 - Whenever the END button is pressed, the screen changes in this order:
“OPERATE” menu → Source screen

To select inputs using the INPUT SELECT buttons on the rear control panel:

- 1) Press the INPUT button.
 - The INPUT SELECT menu is displayed.
- 2) Press the SELECT button to select an input terminal you wish to input.
- 3) Press the ENTER button to execute selection and to switch to the selected input.

NOTE: Pressing the INPUT button deletes the INPUT SELECT menu during input selection.

```

- OPERATE -
1 / PICTURE
2 / POSITION
3 / SOUND
4 / INPUT SELECT
5 / SOURCE INFO
6 / STATIC
7 / CLOSED CAPTION
8 / TIMER
    
```

P01/10-1 INPUT SELECT

		STANDALONE	
NO	NAME	SOURCE	INPUT
01	NTSC3.58	VIDEO	A
02	NTSC4.43	VIDEO	A
03	PAL	VIDEO	A
04	SECAM	VIDEO	A
05	VESA1024	RGB	A
06			
07			
08			
09			
10			

OUTPUT DATA : LIST NO.**

```

INPUT SELECT
INPUT A RGB
INPUT A VIDEO
INPUT A S-VIDEO
INPUT A COMPONENT
INPUT B RGB
INPUT B VIDEO
INPUT B S-VIDEO
INPUT B COMPONENT
INPUT C RGB
INPUT C VIDEO
INPUT C S-VIDEO
INPUT C COMPONENT
    
```

BASIC OPERATION

NOTE:

- While you are viewing a source screen, you can also select the input signal directly by pressing the INPUT "1" through "10" button. In this case INPUT buttons function as follows:

When using the projector in stand alone operation:

Input Mode		RGB	VIDEO	S-VIDEO	COMPONENT	
Input Module						
A		1	2	3	10*1	Standard
With RGB board*2	B	4	4	5	4	Optional (XGRGBIN(A))
	C	7	7	8	7	
With VIDEO board	B	–	4	5	–	Optional (XGVIDIN(B))
	C	–	7	8	–	

*1 Some settings allow you to automatically retrieve a COMPONENT signal after an RGB signal by pressing the INPUT "1" button. See "RGB/COMPONENT Search Setting" on the Set-up manual.

*2 When the RGB input is set, an RGB signal is selected; when the VIDEO input is set, a VIDEO or S-VIDEO is selected.

The RGB input board allows you to switch input signals depending on settings. See the "Part Names and Functions-Optional Boards" on the Set-up manual for more detailed information.

Numbers designate INPUT buttons on the remote control.

When using the projector with the ISS-6020/ISS-6020G:

INPUT 1 through 10 → Selects the corresponding number slot of the ISS-6020/ISS-6020G

When using the projector with two ISS-6020/ISS-6020G or more:

To switch to another input signal, enter the master slot number, then the slave slot number by using INPUT buttons and press ENTER.

Example: If you want to select a signal from the no.3 slot of the slave Switcher which is connected to the no.2 slot of the master Switcher, first press the INPUT "2" button, then the INPUT "3" button and then press ENTER.

- You can switch to any input signal of NO 01 through 10 on the INPUT SELECT list by holding down the CTL button and pressing one of the INPUT buttons corresponding to the input number. To activate this function you must first select ENABLE in the DIRECT ENTRY ACCESS mode. For further details, contact your dealer.

- If there are two or more memory locations that contain the same signal information the projector will reference the signal nearest the beginning of the list. To select the next signal use the CURSOR  or  button and press ENTER.

INPUT SELECT List Format

Page / total pages – sheet No.

Connect condition of the Switcher

P01/10-1 INPUT SELECT				P01/10-2 INPUT SELECT			
STANDALONE				STANDALONE			
NO	NAME	SOURCE	INPUT	NO	DATE	FH	FV
01	NTSC3.58	VIDEO	A	01	00/00/00	15.74kHz	60.00Hz
02	NTSC4.43	VIDEO	A	02	00/00/00	15.74kHz	60.00Hz
03	PAL	VIDEO	A	03	00/00/00	15.74kHz	50.00Hz
04	SECAM	VIDEO	A	04	00/00/00	15.74kHz	50.00Hz
05	VESA1024	RGB	A	05	00/00/00	48.60kHz	60.00Hz
06				06			
07				07			
08				08			
09				09			
10				10			
OUTPUT DATA: LIST NO.**				OUTPUT DATA: LIST NO.**			
Signal name			Registered input module	Entry date		Horizontal Frequency	Vertical Frequency

Output data for the signal currently projected.

Source Information

This is for viewing the signal information and the current status of various settings.

Proceed as follows:

- ① Press the OPERATE button.
 - The “OPERATE” menu is displayed.
- ② Use the CURSOR \blacktriangleleft or \blacktriangleright button to highlight the “5/SOURCE INFO” line and press ENTER to display the “SOURCE INFORMATION” screen. You can also select the “SOURCE INFORMATION” screen directly by pressing the INPUT “5” button.
- ③ Press the CURSOR \blacktriangleleft or \blacktriangleright button to select the page.
- ④ To end the “SOURCE INFORMATION” screen, press the END button.
 - Whenever the END button is pressed, the screen changes in this order:
“OPERATE” menu → Source screen

- OPERATE -	
1 /	PICTURE
2 /	POSITION
3 /	SOUND
4 /	INPUT SELECT
5 /	SOURCE INFO
6 /	STATIC
7 /	CLOSED CAPTION
8 /	TIMER



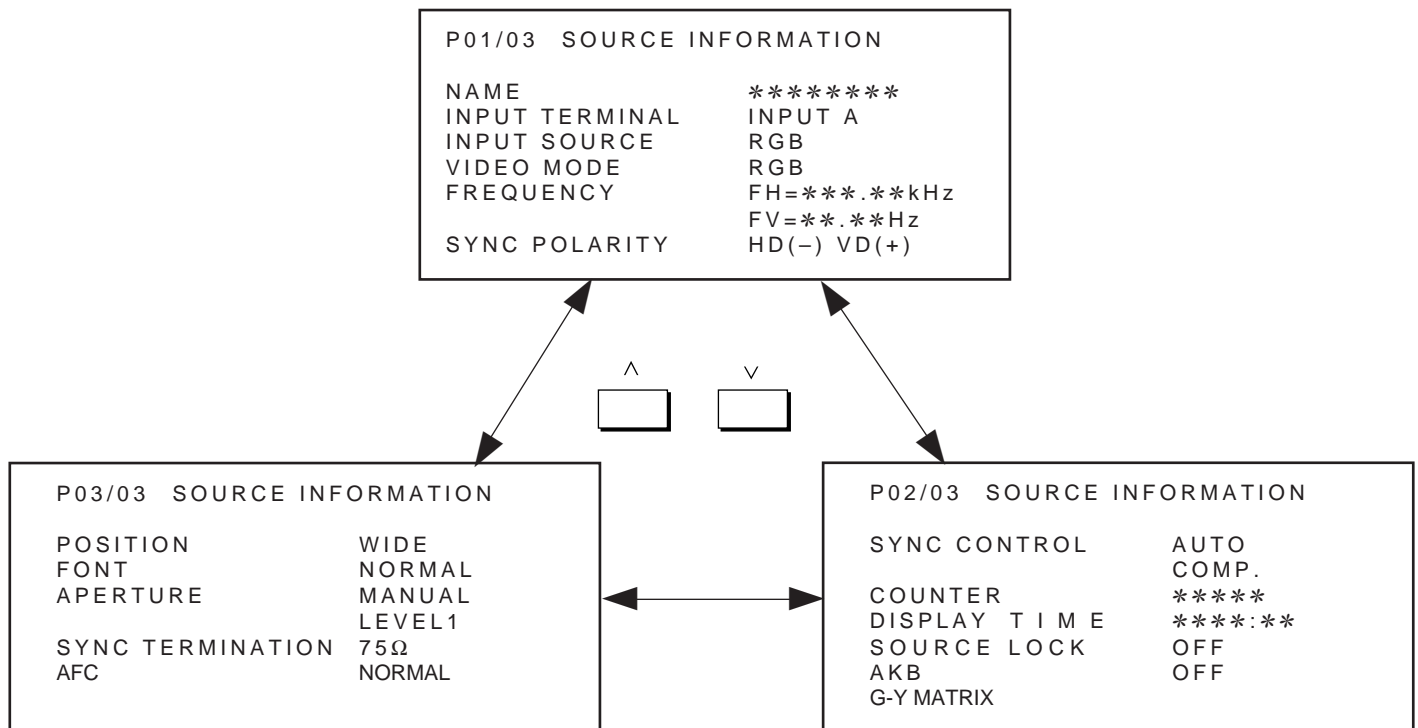

NOTE: The items below cannot be set in the OPERATE mode.



Closed Caption Mode Selection

Several closed caption modes can be set for text to be superimposed on the projection screen.

To select and set a mode, proceed as follows:

- ① Press the OPERATE button.
 - The “OPERATE” menu is displayed.
- ② Use the CURSOR  or  button to highlight the “7/CLOSED CAPTION” item and then press ENTER to display the “CLOSED CAPTION” menu. You can also select the “CLOSED CAPTION” menu directly by pressing the INPUT “7” button.
 - You can also select the CLOSED CAPTION menu by pressing the CAPTION button on the remote control.
- ③ Use the CURSOR  or  button to select a mode, then press ENTER.
 - The mode selection is executed.

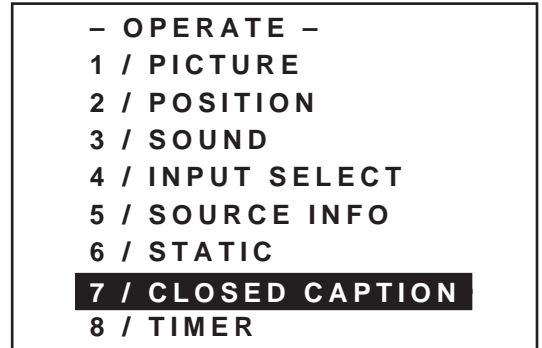

Items to select

- CAPTION 1-4 Text is superimposed
- TEXT 1-4 Text is displayed in full screen
- OFF This exits the CLOSED CAPTION mode

NOTE:

- 1) The closed caption feature will only work with an NTSC3.58 source.
- 2) Pressing ENTER executes store function. Switching to source other than NTSC3.58 will cancel this setting. To activate, select the NTSC3.58 source again.

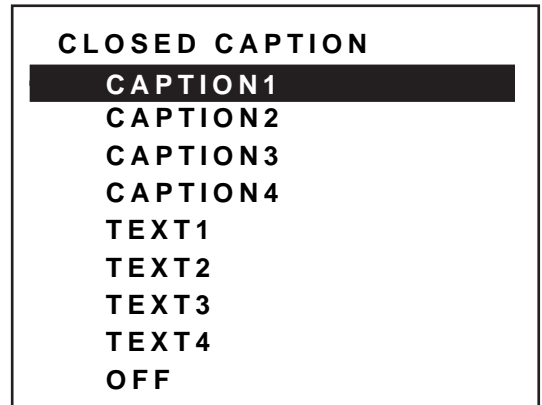

- ④ To return to the operate menu, press the END button.
 - Wherever the END button is pressed, the screen changes in this order:
“OPERATE” menu → source screen

Setting Timer





Your projector can be programmed to turn on or off automatically at a specified time. The two timer functions are available: ON/OFF TIMER and SLEEP TIMER.

NOTE:

When the ON TIMER is set and the projector is in standby, the two digit indicator flashes "00" to indicate that the ON TIMER is active.

Proceed as follows:

- Before setting ON/OFF TIMER, make sure that the DATE, TIME PRESET feature is set.
- Even after setting ON/OFF TIMER, turning the projector on or off with the remote control is possible.
- This timer setting is defeated when the projector carries out a Sequencer program. See "Auto Sequence Setting" in Set-Up manual for more information.
- There are two time display formats: 24-hour or AM/PM format. You can set either format in the "DATE TIME DISPLAY" of the OPTION menu. See "Various Settings-Setting DATE, TIME DISPLAY Setting" in the Set-Up manual.

- ① Press the OPERATE button.
 - The "OPERATE" menu is displayed.
- ② Use the CURSOR  or  button to highlight the "8/TIMER" item and then press ENTER to display the "TIMER" menu. You can also select the "TIMER" menu directly by pressing the INPUT "8" button.
- ③ Use the CURSOR  or  button to select "ON/OFF TIMER" or "SLEEP TIMER".





Items to select

- ON/OFF TIMER Programs to turn on or off the power at a predetermined time.
- SLEEP TIMER Programs to turn off the power at a predetermined time, up to two hours later in 30-minute increments.

- OPERATE -
1 / PICTURE
2 / POSITION
3 / SOUND
4 / INPUT SELECT
5 / SOURCE INFO
6 / STATIC
7 / CLOSED CAPTION
8 / TIMER

- TIMER -
1 / ON / OFF TIMER
2 / SLEEP TIMER

■ Setting ON/OFF TIMER

- 1) Use the CURSOR  or  button to select "ON/OFF TIMER" and press ENTER to display the "ON/OFF TIMER" menu. You can also select the "ON/OFF TIMER" menu directly by pressing the INPUT "1", or by holding down CTL and pressing POWER ON on the remote control.
- 2) Use the CURSOR  or  button to highlight the program number and press ENTER to display the selected "PROGRAM" screen. You can also select the "PROGRAM" screen by INPUT "1" through "8" button.

- 3) Use the CURSOR or button to select “EDIT” or “CLEAR”, and then press ENTER.

Items to select

- EDIT ----- Enters the mode for changing setting time.
- CLEAR ----- Deletes the current setting time.

When making a new setting or selecting “EDIT”:

Select “EDIT”, and press ENTER to display the “DAY” setting menu which allows you to set the day of the week for TIMER.

- a) Use the CURSOR or button to select the day of the week to be registered and press ENTER.
- The “EVERY WEEK” menu is displayed.

Items to select

- MON ----- Monday
- TUE ----- Tuesday
- WED ----- Wednesday
- THE ----- Thursday
- FRI ----- Friday
- SAT ----- Saturday
- SUN ----- Sunday
- MON-FRI ----- Monday thru Friday
- MON-SAT ----- Monday thru Saturday
- MON-SUN ----- Monday thru Sunday

- b) Use the CURSOR or button to select an item and then press ENTER.
- When “YES” is selected, the item on the day field in the ON/OFF TIMER menu is marked with the letter “E” which indicates that the setting time is enabled.

Items to select

- YES ----- Programs to turn on or off every week.
(not deleted after executing the program)
- NO ----- Does not program to turn on or off every week.
(deleted after executing the program)

- The “ON TIMER” setting screen is displayed.
- c) Enter the ON TIMER time in the HH:MM format using INPUT buttons and the CURSOR or button and then press ENTER. Pressing NORMAL cancels the ON TIMER time.

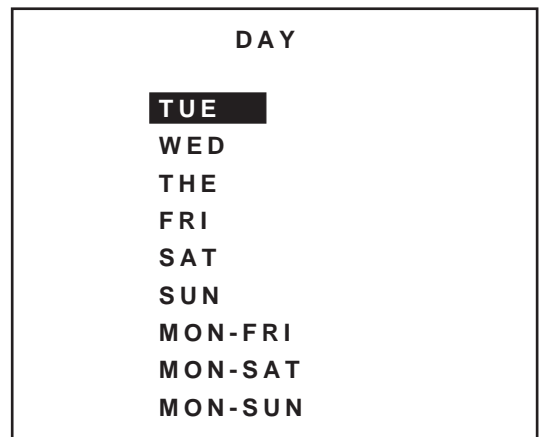
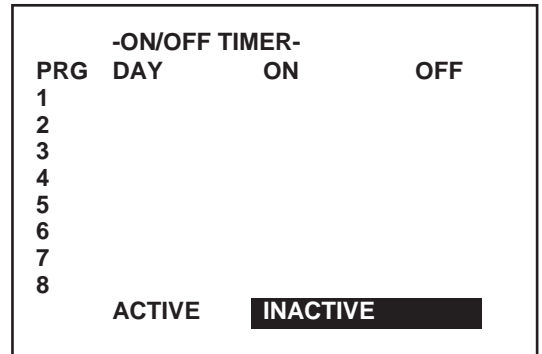

BASIC OPERATION



- The time display format varies depending on the setting in “DATE TIME DISPLAY” of the “OPTION” menu.
- The “OFF TIMER” setting screen is displayed.

NOTE:

When the ON TIMER is set alone, the timer is programmed to turn off after four hours. While this setting is effective, if any button on the remote control or the rear panel is pressed, or if any operation is made from the external control, the timer will extend the current setting time to add four more hours.

ON TIMER 09 : 00

OFF TIMER 12 : 00

- d) Enter the OFF TIMER time in the HH:MM format using INPUT buttons and the CURSOR  or  button and then press ENTER. Pressing NORMAL cancels the OFF TIMER time.
- The time display format varies depending on the setting in “DATE TIME DISPLAY” of the “OPTION” menu.
 - The “ON/OFF TIMER” setting screen is displayed.

-ON/OFF TIMER-			
PRG	DAY	ON	OFF
1	MON	09:00	12:00
2	MON-FRI	14:00	15:30
3	MON-SAT	18:00	19:00
4	TUE	22:00	06:00
5			
6			
7			
8			
		ACTIVE	INACTIVE

When selecting “CLEAR”:

Select “CLEAR” and press ENTER to clear the setting time for the selected program number.

- The “ON/OFF TIMER” menu is displayed.

- 4) Use the CURSOR  or  button to select “ACTIVE” or “INACTIVE” and then press ENTER.

Items to select

- ACTIVE ----- Enables ON/OFF TIMER
- INACTIVE ----- Disables ON/OFF TIMER

-ON/OFF TIMER-			
PRG	DAY	ON	OFF
1	MON	09:00	12:00
2	MON-FRI	14:00	15:30
3	E MON-SAT	18:00	19:00
4	TUE	22:00	06:00
5			
6			
7			
8			
		ACTIVE	INACTIVE

When selecting “ACTIVE”:

Select “ACTIVE” and press ENTER to enable the programmed timer function.

- The “ON/OFF” display appears on the top left of the screen. When the all the programs are completed, this display disappears.
- When the OFF TIMER is set, the “THE PROJECTOR WILL TURN OFF SOON” display appears three minutes before turning off.



MON 01/16/97 12:00:00
ON/OFF

When selecting “INACTIVE”:



Select “INACTIVE” and press ENTER to disable the programmed timer function.

- The screen is returned to the “TIMER” menu and the “ON/OFF” display disappears.

■ Setting SLEEP TIMER

1) Use the CURSOR  or  button to highlight the “2/ SLEEP TIMER” and press ENTER to display the “SLEEP TIMER” menu. You can also select the “SLEEP TIMER” menu directly by pressing the INPUT “2” or by holding down CTL and pressing POWER OFF on the remote control.



2) Use the CURSOR  or  button to select the time between 30 minutes and 2 hours in 30 minutes.



Items to select

- --:-- ----- Does not use SLEEP TIMER
- 0:30 ----- 30 minutes
- 1:00 ----- 1 hour
- 1:30 ----- 1 and half an hour
- 2:00 ----- 2 hours



3) Select the desired time and press ENTER.

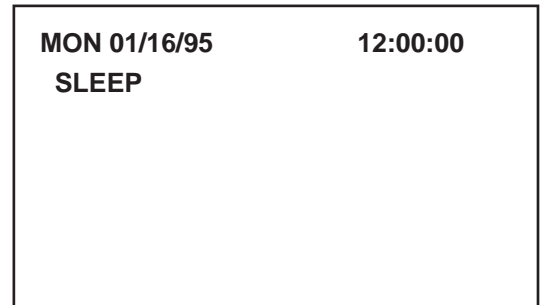

- The “SLEEP” display appears on the top left of the screen.
- When the SLEEP TIMER is set, the “THE PROJECTOR WILL TURN OFF SOON” display appears three minutes before turning off.



4) To refer the remaining time, select the “2/SLEEP TIMER” in the “TIMER” menu and press ENTER to display the SLEEP TIMER screen. This indicates the remaining time.

- You can also display the remaining time by holding down CTL and pressing POWER OFF on the remote control.
- To change the setting time, repeat the step 2).



5) To cancel the setting sleep time, select the “2/SLEEP TIMER” in the “TIMER” menu and press ENTER to display the SLEEP TIMER screen. This indicates the remaining time. Use the CURSOR  or  button to clear the settings. The display changes to “--:--”. Then press ENTER.

- The “SLEEP” display disappears on the top left of the screen.
- You can also cancel the time by holding down CTL and pressing POWER OFF on the remote control.

④ To return to the source screen, press the END button while the TIMER menu is displayed.

- Wherever the END button is pressed, the screen changes in this order:
“TIMER” menu → “OPERATE” menu → source screen

BASIC OPERATION

Mute

This function mutes the picture, sound or on-screen display.

To mute picture:

- Press the PICTURE MUTE button. To restore the picture, press the PICTURE MUTE button again or the END button. You can also mute the picture by holding down CTL and pressing PICTURE MUTE.

To mute sound:

- Press the SOUND MUTE button. To restore the sound, press the SOUND MUTE button again or the END button.

To mute on-screen display:

- Press the DISPLAY button. To restore the on-screen display, press the DISPLAY button again or the END button. Pressing CTL + DISPLAY button together will eliminate the on-screen display: pressing this combination again will restore the display.

NOTE: The OPERATE menu can be accessed in the PICTURE MUTE mode.

See “Remote Control Unit” of “Part Names and Functions” for more details.

Normal, Load, and Cancel Function

Adjustment settings can be returned to the factory preset level, or previously stored level, or can be cancelled.

To return to the standard level (NORMAL):

- ① Press the NORMAL button.
 - A confirmation message will be displayed.
- ② Use the CURSOR or button to select “YES”.
- ③ Press ENTER.
 - The NORMAL function is performed.
 - If you select “NO”, you will exit this mode suspending current status.

To return to the last stored level (LOAD):

- ① Press and hold the CTL button then press the NORMAL button.
 - The “LOAD/CANCEL” menu is displayed.
- ② Use the CURSOR or button to select “LOAD”.
 - A confirmation message is displayed.
- ③ Use the CURSOR or button to select “YES”.
 - If you select “NO”, you will exit this mode suspending current status.
- ④ Press ENTER.
 - The LOAD function is performed.

To cancel the adjustment data (CANCEL):

- ① Press and hold the CTL button then press the NORMAL button.
 - The “LOAD/CANCEL” menu is displayed.
- ② Use the CURSOR or button to select “CANCEL”.
 - A confirmation message is displayed.
- ③ Use the CURSOR or button to select “YES”.
 - If you select “NO”, you will exit this mode suspending current status.
- ④ Press ENTER.
 - The CANCEL function is performed.

XXXXXXXX
DATA NORMALIZE?

YES

NO

XXXXXXXX refers to a specific adjustment item to be normalized

XXXXXXXX

LOAD

CANCEL

XXXXXXXX refers to a specific adjustment item to be loaded or cancelled

XXXXXXXX
DATA LOAD?

YES

NO

XXXXXXXX refers to a specific adjustment item to be loaded

XXXXXXXX
DATA CANCEL?

YES

NO

XXXXXXXX refers to a specific adjustment item to be cancelled

Data Area for Output and Storage

Adjustment data have different reference data areas depending on each operation.

Adjustment data fall into two: REF. ADJUST menu adjustment and the other adjustment data (Operate and Adjust menu).

Data area falls into five:

Adjustment Data

All Gain : All adjustment data except Ref.Adjust data

Ref. Adjust : Ref.Adjust data

Data Area

INPUT LIST (00-99) : Registered data (100) areas corresponding to INPUT LIST

DEFAULT DATA (1-6) : Default (6) areas divided by horizontal frequency.

Cancel Data : Data to be returned to default

Ref.Adjust Data : REF.ADJUST data (1) area

Ref.Adjust (FACTORY AREA) : REF.ADJUST data (1) area for factory preset.

NOTE: See the Set-up manual for ADJUST and REF.ADJUST menus.

Output Data Area

	All Gain	Ref.Adjust Data
Signal Select	Input List (00-99) or Default Data (1-6)	Ref. Adjust Data
Normalize	Default Data (1-6)*	Ref. Adjust Data (Factory Area)
Load	Input List (00-99)*	Ref. Adjust Data
Cancel	Cancel Data*	←

* The above list may be different if NORMAL/LOAD/CANCEL operation is performed during POINT convergence.

Output data during adjusting is the amount of data in each data area and data other than the current adjustment item (data in working area).

Example for FINE adjustment

	Point Data while adjusting Fine
Normalize	Default Data (1-6) + Point data except the current Fine data
Load	Input List (00-99) + Point data except the current Fine data
Cancel	Cancel Data + Point data except the current Fine data

Storage Area of Data

	All Gain	Ref. Adjust
STORE	INPUT LIST (00-99)*	REF. ADJUST

* Point adjustment has more than one item and each item has its own working area. However, there is only one area where data is saved with the Store function, which means no distinction is made among items in data.

Searching Registered Signals

When switching source is performed with the remote control or a signal is input, the projector searches the registered signals and outputs its adjustment data as follows:

By using the horizontal frequency the projector searches up to 100 signals previously stored in the INPUT LIST and up to six signals stored in the DEFAULT AREA for a matching or close data to output.

- * When a matching data is found in the INPUT LIST, the matching data will be displayed.
- * When a data with a different input terminal is found, the input terminal and input signal name will be displayed in yellow and output its data.
- * When the data is found in the DEFAULT AREA, the data will be displayed as NEW SIGNAL.
- * When no matching data is found, the nearest thing to a NEW SIGNAL data will be displayed.

This section helps you resolve problems you may encounter while inputting a COMPONENT signal.

- * When a copy-guard-capable software source is played on a DVD player, white lines outside of a picture may appear. If this happens, perform the blanking adjustment.

Regardless of whether or not using a DVD player, when a copy-guarded signal is input, a picture may be distorted at the top of the screen. If this happens, enlarge the image size to display the portion of distortion outside of the screen.

- * When switching signals with the external equipment, there may be cases where G-Sync and DVD signals with horizontal frequencies of approximately 15 kHz cannot be discriminated. There may be cases where an unregistered G-Sync signal with a horizontal frequency of approximately 15 kHz may be mistaken for a DVD signal and may not be displayed correctly. When using G-Sync and DVD signals with horizontal frequencies of approximately 15 kHz at the same time, do not use the same input terminal.
- * A COMPONENT signal can be input with the RGB input board installed when the projector is used with the ISS-6020 switcher on the SW level mode. To enable this, you must first specify the RGB input board as the COMPONENT input board on the projector. See “Setting Mode-RGB/COMPONENT Searching of the Set-up manual.

Screen Format in Projecting a Picture

NOTE: The example of the screen display is only when used with the ISS-6020/ISS-6020G.

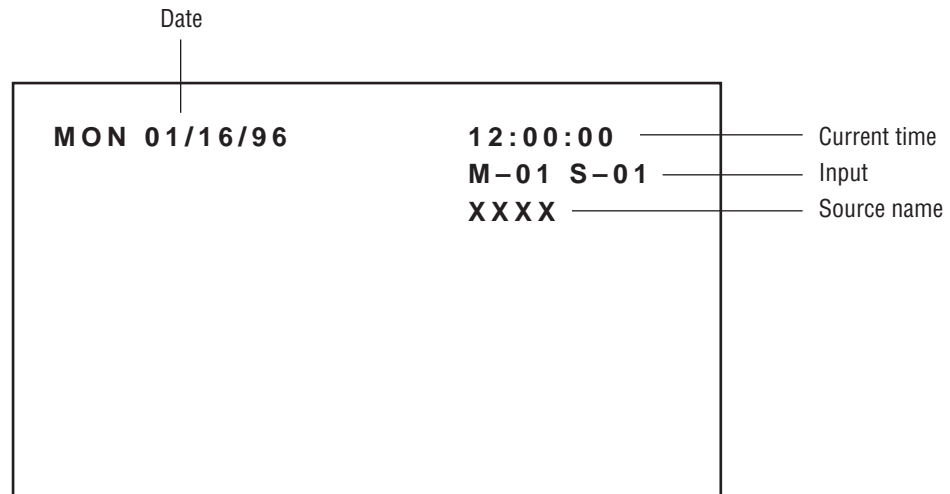
**NOTE:**

- See the Set-Up manual for changing the on-screen display mode.
- If the main power is not supplied to the projector for three days or more, the built-in clock may be reset. If this happens, contact your dealer for setting date and time.

SPECIFICATIONS

Projection type	Rear projection, console	Setup signal	Cross hairs, Cross hatch, Dot, Window Pattern, H test pattern
Projection system	3 lens and 3 CRTs in-line	Power supply	AC 120V 60Hz
Scanning frequency	XG135RP	Input current	7.4A (AC 120V)
	H 15 to 135 kHz/V 40 to 160Hz	Safety and regulation	Meets FCC class A requirements
	XG85RP/XG85RPW		UL Approved (UL 1950, CSA 950)
	H 15 to 85 kHz/V 40 to 160Hz		DHHS Approved
Retrace time	H 6.0 μ S (fH 15 to 30kHz)		Meets DOC (Canada)
	H 2.6 μ S (fH 30 to 77kHz)		Meets RED ACT
	H 2.0 μ S (fH 77 to 120kHz)		
	H 1.4 μ S (fH 120 to 135kHz)		
	V 270 μ S	Cabinet dimensions	
Video bandwidth	150MHz (-3dB) XG135RP	XG85RP/XG135RP	57 11/16 (W) \times 32(D) \times 78 7/16(H) inch
	110MHz (-3dB) XG85RP/XG85RPW		(42 1/4(D) : mirror at the maximum out position)
CRT	8 inch liquid cooled	XG85RPW	57 11/16 (W) \times 32(D) \times 72 15/16(H) inch
	Deflection angle 90 degrees		(42 1/4(D) : mirror at the maximum out position)
Lens	Hybrid lens with ECP and ARC	Weight	217.5 kg/479 lbs
	(ECP: Enhanced Color Purity, except B-lens,	Upper	92.6 kg/204 lbs
	(ARC: Anti-Reflective Coating)	Lower	124.9 kg/275 lbs with chassis projector installed
	HD-70(RGB)(XG85RP/XG85RPW)		61.3 kg/135 lbs without projector
Picture size	72 inches diagonal (4:3)/66 inches diagonal (16:9)	Remote control	Wired application
Resolution	1100TV lines at center (HDTV)		Wireless (operating distance 7m/23ft.)
Pixel resolution	2500 \times 2000 dots (Addressable)	Remote control functions	User remote (RC-6320); Power ON/OFF, Input signal select, Picture mute, Bright, Contrast, Color
	(XG85RP/XG85RPW: 1600 \times 1200 dots)		¹⁾ Sharpness ¹⁾ , Tint ²⁾ , Volume, Sound mute, Source information, Static convergence, Normal-
Light output	850 cd/m ² (White peak)		ize, Enter, End, Closed Caption
High voltage	32kV		Full function remote (RC-6321); Test, Display, Help, Information, Input list, Static focus, Edge focus, H/
Input	RGB signal 0.7Vp-p 75 ohm positive (BNC)		V position, White balance select, Static conver-
	H/V sync 0.7 to 4.0Vp-p 75 ohm/1K ohm negative or positive (BNC)		gence, Wave convergence, Point convergence, H/V
	COMP sync 0.7 to 4.0Vp-p 75 ohm/1K ohm negative or positive (BNC)		amplitude, H/V linearity, H/V key-stone, H/V pin-
	Sync on G 0.3 to 0.6Vp-p 75 ohm negative (BNC)		cushion, H/V blanking, Tilt, Skew, H/V bow, Store, Normalize, Enter, End
	Y, Cr, Cb: Y1.0Vp-p 75 Ω Sync negative (BNC)	Main control function	Power ON/OFF, Input signal select,
	Cr, Cb 0.7Vp-p 75 Ω (BNC)(same as Y, Pb, Pr)	External control	Power ON/OFF, Input signal select, Picture mute, Sound mute, Remote control data input
	COMP Video 1.0Vp-p 75 ohm positive (BNC)	PC control	Acceptable (Optional)
	S-video: Y 1.0Vp-p 75 ohm positive	Supplied accessories	Full function remote control unit (RC-6321), User remote control unit (RC-6320), Remote cable 16m/52ft., AC line cable, Operation manual, Set-Up manual
	C 0.28Vp-p 75 ohm (burst level)	Environment	Temperature 0 to 40 degrees C
	Video system NTSC, PAL, SECAM and NTSC4.43		Humidity 0 to 90% non-condensing
	Audio: 0.5 Vrms, 47k Ω , L, R (RCA)		Storage -10 to 50 degrees C
	RGB, VIDEO, S-Video	Sound emission	Less than 45dB (A). Complies with ISO 3744 or ISO 7779
Convergence	Digital convergence (Pre-set 100 positions)		
	Quick copy convergence		
	Static and wave convergence		
	Point convergence, Zone convergence		
Convergence limits	Less than 0.2% of V-height		
Audio output amplifier	20W+20W, 6 ohm		
Warm up time	20 minutes		

1) This works only for VIDEO and COMPONENT signals.

2) This works only for NTSC video and COMPONENT signals.

Specifications are subject to change without notice.
The dimensions given for the projector do not include protruding parts.

Cabinet Dimensions

Unit=inch

XG-85RP
XG-1352RP

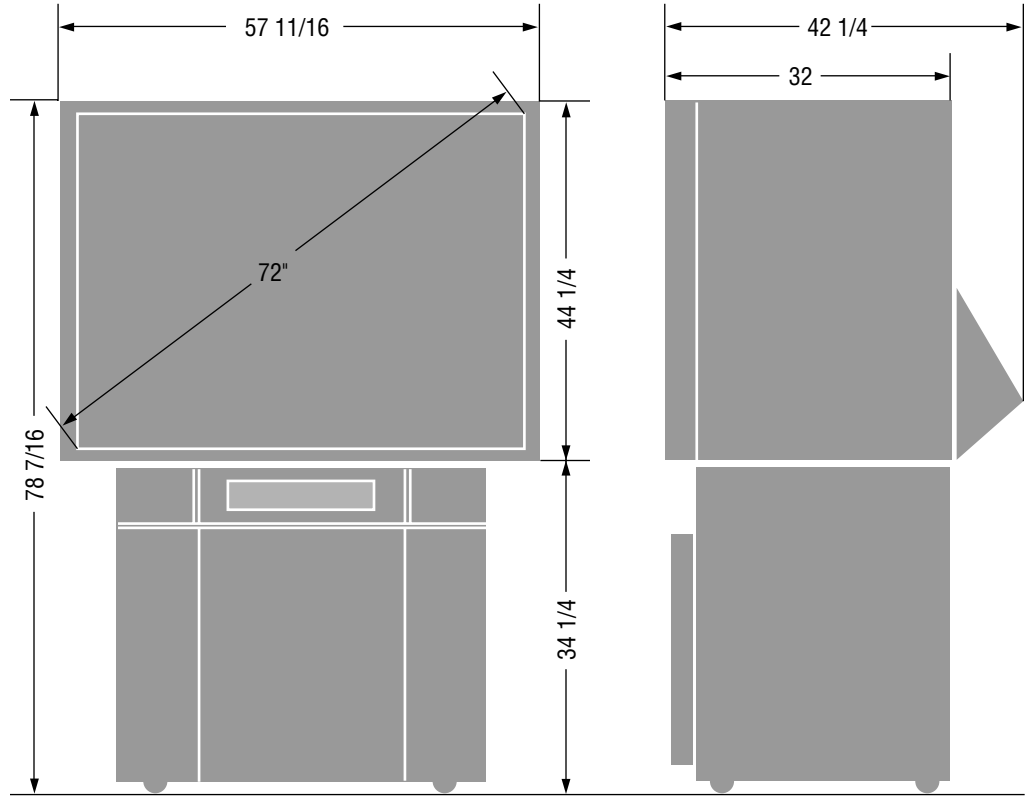

XG-85RPW

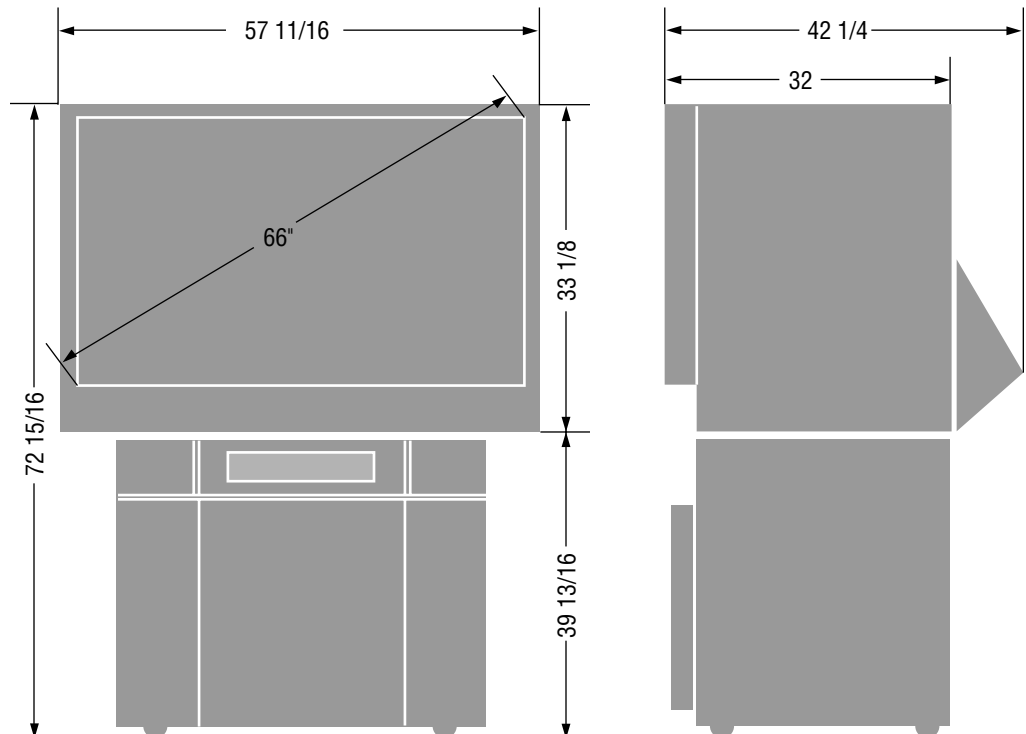

NEC
NEC Corporation