

Operating Instructions

Color Projection System

Models No. **PT-M1085U**
PT-M1083U

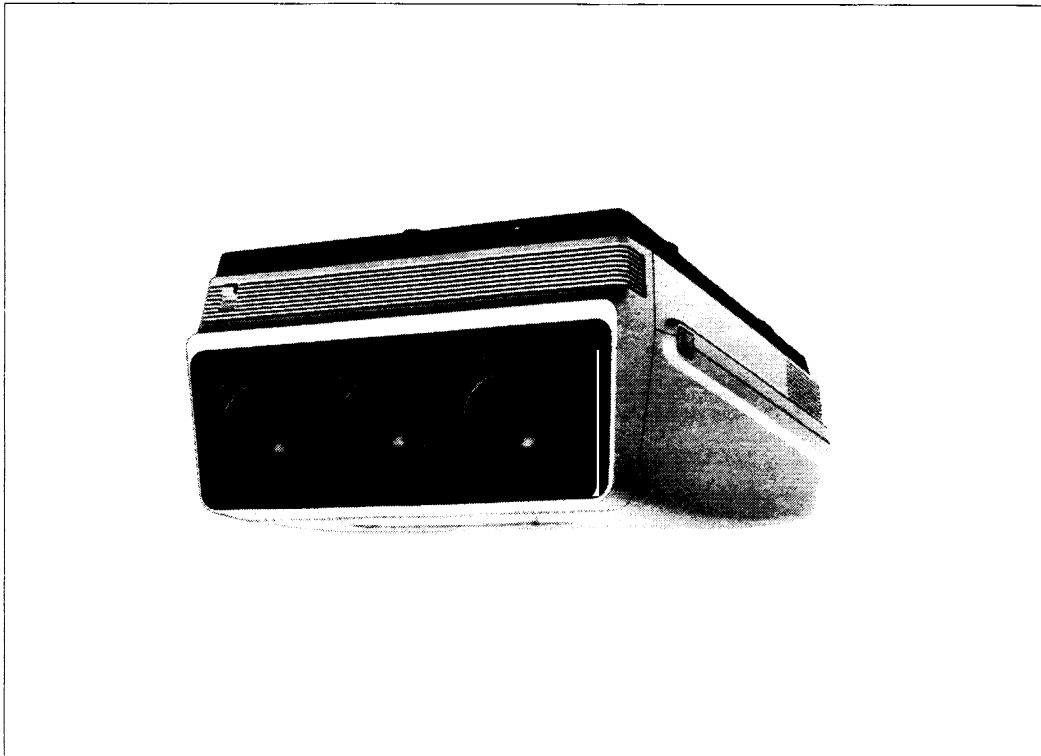

Panasonic[®]

Read these instructions completely before operating this unit.

Dear Panasonic Customer:

Welcome to our Panasonic family of customers. It is our desire that you receive many years of enjoyment from your new Projector. In keeping with the state of the art, we have built quality, reliability, and performance into your unit.

However, for best performance, this unit should be suitably positioned in the viewing area and properly adjusted.

Customer's Record:

The serial number of your product may be found on its side. You should note it in the space provided below and retain this booklet in case service is required.

Model numbers: **PT-M1085U/PT-M1083U** Serial number: _____





Contents

IMPORTANT SAFETY NOTICE	2
Introduction	3
Features	3
Precautions with regard to operation	4
Location of each projector part	8
Location of each remote control unit part	10
Preparation	12
Inserting the batteries	12
Attaching the strap	12
Using the remote control unit without the cable	13
Connecting the remote control unit to the projector	13
Controlling two or more projectors	14
Operating the projector	16
Turning the main power on and off	16
Turning the power on and off	16
Selecting the input	17
Changing the system format	17
Adjusting the picture quality	18
Resetting picture adjustments to default settings	20
Viewing the status and recorded data for input signals	21
ASPECT button	22
Controlling the volume	23
Turning the on-screen display function on and off	24
Using the picture noise reduction function	24
Function menu	25
Using the ID function	26
Using the REMOTE IN 1 connector	27
System configuration examples	28
Input signal recording function	33
Optimum viewing position	34
Setting-up examples	35
Requirements for the screen	38
Troubleshooting	40
Specifications	41

IMPORTANT SAFETY NOTICE

WARNING: To prevent damage which may result in fire or shock hazard, do not expose this appliance to rain or moisture.

Power Supply: This Projector is designed to operate on 120 volts, 60Hz, AC house current only.

 <div style="border: 1px solid black; padding: 2px; display: inline-block;"> CAUTION <small>RISK OF ELECTRIC SHOCK DO NOT OPEN</small> </div> 	 <p>The lightning flash with arrowhead symbol, within an equilateral triangle, is intended to alert the user to the presence of uninsulated "dangerous voltage" within the product's enclosure that may be of sufficient magnitude to constitute a risk of electric shock to persons.</p>
<p>CAUTION: TO REDUCE THE RISK OF ELECTRIC SHOCK, DO NOT REMOVE COVER (OR BACK). NO USER-SERVICEABLE PARTS INSIDE. REFER SERVICING TO QUALIFIED SERVICE PERSONNEL.</p>	 <p>The exclamation point within an equilateral triangle is intended to alert the user to the presence of important operating and maintenance (servicing) instructions in the literature accompanying the product.</p>

CAUTION: This equipment is equipped with a three-pin grounding-type power plug. Do not remove the grounding pin on the power plug. This plug will only fit a grounding-type power outlet. This is a safety feature. If you are unable to insert the plug into the outlet, contact an electrician. Do not defeat the purpose of the grounding plug.

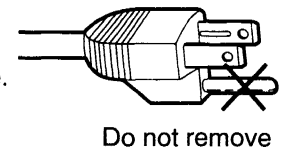

WARNING: This equipment has been tested and found to comply with the limits for a Class A digital device, pursuant to Part 15 of the FCC Rules. These limits are designed to provide reasonable protection against harmful interference when the equipment is operated in a commercial environment. This equipment generates, uses, and can radiate radio frequency energy and, if not installed and used in accordance with the instruction manual, may cause harmful interference to radio communications. Operation of this equipment in a residential area is likely to cause harmful interference in which case the user will be required to correct the interference at his own expense.

CAUTION: Any unauthorized changes or modifications to this equipment would void the users authority to operate.

CAUTION: Recommended shielded cable must be used in order to meet FCC emission limits and also to prevent interference to nearby radio and television reception.

PRECAUTION: To prevent permanent burning of the picture tubes do not operate the projector with a still picture for an extended time period when not necessary and be certain to turn power off when not in use.

Burned picture tubes are not covered under warranty.

Introduction

The PT-M1085U/1083U multi-scan projector automatically tracks the frequency of incoming analog RGB signals and projects them using a newly-developed electrostatically-focused projection tube and a large-diameter F1.03 hybrid lens. It accepts composite video and S-VIDEO signals in four different formats (NTSC, M-NTSC, PAL and SECAM), and can distinguish what type of signal is being input and automatically switches input circuits depending on what type of signal it detects. The projector can receive RGB signals with horizontal scanning frequencies of up to 100 kHz and vertical frequencies of up to 150 Hz. (*1)

The incoming signals are distinguished by their scanning frequencies, and one of three adjustment configurations can be applied to each type of signal to change properties such as the aspect ratio.

The projector has a number of remote connectors which make it possible for the projector to be connected to an external control device. Furthermore, the remote control is provided with a cable which can be used to connect the remote control unit to the projector. An ID number function can also be used to run multiple projectors simultaneously as a whole system. Once the projector to be operated is specified, all operations from adjustment to operation can easily be carried out using the remote control unit.

(*1): These figures are for the PT-M1085U. The PT-M1083U can receive RGB signals with horizontal scanning of up to 70 kHz and vertical scanning frequencies of up to 150 Hz.

Features

■ A wide variety of terminals and automatic frequency tracking

To enable the projector to be connected to a wide variety of different types of signal sources, the following terminals and connectors are provided.

- Analog RGB IN 1 terminals (BNC × 5)
- Analog RGB IN 2 terminal (D-SUB HD15-pin)
- S-VIDEO IN terminal (Mini DIN 4-pin)
- LINE (composite video) IN/OUT terminals (BNC × 2)
- Audio IN/OUT terminals (Stereo RCA jack × 4)

In addition, the projector is equipped with a multi-scan function automatically tracks the frequency of input signals. The following types of signals can be tracked using this function.

- Analog RGB signals
 - Horizontal scanning frequency 15 ~ 100 kHz (*2)
 - Vertical scanning frequency 38 ~ 150 Hz
- Composite video and S-VIDEO signals
 - NTSC, M-NTSC, PAL and SECAM

■ The latest in design and development technology

This projector features the latest in projection technology to provide high-contrast color reproduction and high-quality projected images. Features include the following:

- 7-inch liquid cooled high-brightness focusing tubes
- Electrostatic focus
- Large-diameter F1.03 hybrid lenses with red and green color lenses
- G1 brightness control circuit
- High-voltage rectangular wave circuit
- ABL circuit for each projection tube
- Gamma compensation circuit
- High-frequency 90 MHz video output circuit (*3)
- High resolution 1,600 × 1,280 dots (*4)

■ Multi-function remote control unit

All functions from adjustment to operation can be carried out using the accessory single remote control unit which has 43 buttons and can perform up to 62 functions. The remote control unit can be operated in either of two modes: one mode is for normal daily operation, and the other mode should only be used by a qualified technician when carrying out adjustment.

A button illumination function makes it easy to see the buttons even in dark rooms, plus there is a battery check function to warn you when the battery power is getting low. A strap is provided for easy carrying, and you can choose between wired operation (connecting the remote control unit to the projector by means of a cable) and wireless operation.

■ ID number function

This function lets you operate two or more projectors as a single system. A maximum of eight ID numbers can be used as ID numbers for remote control operation. You can select which projectors are to be operated by selecting the corresponding ID number for those projectors.

■ Built-in self-diagnosis function

If a problem should develop, the self-diagnosis circuit displays the cause of the problem in a two-digit format on the projector's LED display, thereby making maintenance much easier.

■ 21-zone convergence adjustment function and seven built-in test pattern signals

The 21-zone convergence adjustment function makes it possible to adjust the convergences right to the edge of the picture area in order to eliminate color misalignment.

Seven test patterns (crosshatch, dot, H character, window, full white, pluge and crosshair) are also included to give improved adjustment precision.

■ External control connectors

The projector is supplied with connectors which can be used to connect an external control device or a personal computer.

(*2): This figure is for the PT-M1085U. The maximum horizontal scanning frequency for the PT-M1083U is 70 kHz.

(*3): This figure is for the PT-M1085U. The value for the PT-M1083U is 75 MHz.

(*4): This figure is for the PT-M1085U. The value for the PT-M1083U is 1,500 × 1,200 dots.

Precautions with regard to operation

■ Precautions with regard to setting up

The following points should always be observed when setting up this projector.

1. Installation and adjustment of this projector should only be carried out by a qualified technician. In order to maintain full safety and precision during installation and adjustment, such work should only be carried out by a qualified technician.
2. If changing the installation method from ceiling to floor mounting or setting up behind the screen, or if changing the screen size from between 60 ~ 79 inches to between 121 ~ 300 inches, it will be necessary to replace and adjust some of the projector components.
3. This unit weighs 136.4 lbs. (62 kg). Installing this unit in a place which is not strong enough to bear the projector's weight could result in a serious accident occurring. Check with a qualified technician before the projector is set up, and if the desired place is not strong enough, reinforce it accordingly so that there will be no problems with safety.

4. Avoid setting up in places which are subject to vibration or shocks.
If the projector is set up in locations with strong vibration, such as near a motor, or if it is installed inside a vehicle or on board a ship, the projector may be subjected to vibration or shocks which can damage the internal parts and cause malfunction, misalignment or accidents. For increased reliability, set up the projector in a place which is free from such vibrations and shocks.
5. Environmental conditions
The projector should be set up in a place with an ambient temperature of -5 to 40°C and a relative humidity of 20 to 80%. Furthermore, several fans inside the projector radiate heat through vents in the projector cabinet in order to prevent the temperature inside the projector from rising too high, so do not restrict the flow of air past these vents.
6. Do not place the projector near strong magnetic fields.
If the projector is placed close to objects such as magnets, speakers, high-voltage wires or motors which generate magnetic fields, color or picture distortion or other electromagnetic interference may occur.
7. Do not move the projector after setup and adjustment.
If the distance between the projector and the screen is changed or if the projector is moved to a different place after setup and adjustment, color mis-convergence may occur which will require readjustment to be carried out. Be particularly careful of this if setting up the projector on the floor.
8. A special attachment (sold separately) is necessary for ceiling installations.
If suspending the projector from the ceiling, please use the special attachment (ET-PK180).
9. If changing the system connections, readjustment may be necessary.
If you change around the components which are connected to the system, operations such as convergence or amplitude adjustment may need to be carried out once more.
Please consult with a qualified technician before changing the system connections.

Using the adjusters on the front legs

The front legs which are attached to the base of the projector are equipped with adjusters which make it possible to adjust the angle of the projector so that it can sit horizontally on surfaces which are not perfectly level.

- Do not turn these adjusters after projection adjustment has been completed, as this will cause the relative angle between the projector and the screen to change.

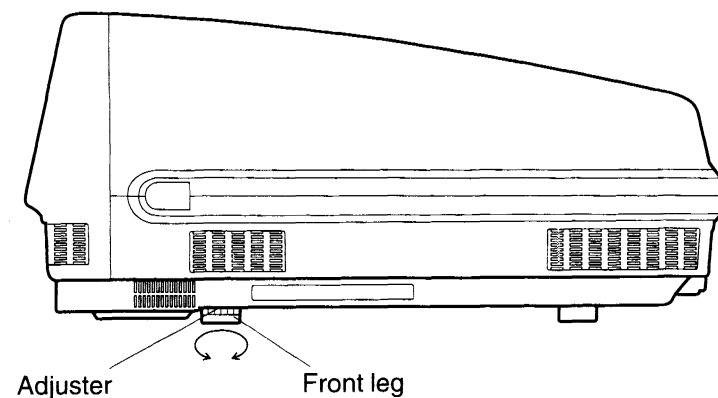

Precautions with regard to safety

To ensure safe operation, please observe the following.

- If there is a problem, immediately turn off the power and then contact the place of purchase.
If no image is projected, if smoke comes out from the projector, or if any strange noises or smells are observed, you should not continue using the projector. Turn off the power immediately, disconnect the plug from the wall outlet and then ask your dealer to carry out repairs.
- Do not modify the projector yourself or use it with the cover open.
High voltages are present inside the projector, and you can receive a dangerous electric shock if you touch these places. Any internal inspection and repair work should be referred to a qualified technician.
- If the projector is not used for long periods.
If you will not be using the projector for long periods, disconnect the plug from the wall outlet.
- Do not let foreign materials get inside the projector.
Be careful not to spill any liquids or drop any flammable or metallic items onto the projector. If any foreign substances should get inside the projector, turn off the power immediately, disconnect the plug from the wall outlet and then contact your dealer. If you continue to use the projector in this condition, fire or other serious malfunctions could result.
- Handle the power cord carefully.
If the power cord becomes damaged in any way, live wires may become exposed, which could result in fires or electrical shocks. Ask your dealer if you need to have the power cord or plug repaired or replaced.
- Clean inside the projector once a year.
If dust is allowed to collect inside the projector, fires or other serious malfunctions may result. To prevent this, please have a qualified technician to clean inside the projector at least once a year. In particular, this should be carried out before seasons when high humidity is common.
- Check the power supply voltage.
If the voltage of the power supply being used is too high or too low, the working life of the projector will be adversely affected, or malfunctions could result. Ask your dealer to measure the power supply, and have them carry out any remedial measures if necessary before using the projector.
- Do not expose the projector to direct heat from steam, kerosene heaters or air conditioners.
This will damage the internal components of the projector.
- Do not subject the projector to shocks.
Be particularly careful not to hit or scratch the surfaces of the magnification lenses.
- Do not place heavy objects on the projector.
Never drop the projector, place heavy objects on it or otherwise subject it to heavy loads, as such things can seriously damage the projector.
- Do not look into the magnification lenses while the projector is operating.
Strong light is emitted from the magnification lenses in order to magnify the image being projected. If you look directly into a lens, the strong light can be extremely harmful to your eyes.

Precautions during use

- In order to get the finest best picture quality
If outside light or light from indoor lamps is shining onto the screen, the images projected will not have good contrast. Draw curtains over any windows, turn off any fluorescent lights near the screen and cover any highly-reflective floor and wall surfaces with carpet or wallpaper to prevent reflection.
- Do not pause the image projection for long periods.
If the same image is continuously projected for long periods of time or a bright signal which is above the rated level is input, the image may become burned into the fluorescent surface of the projection tube.
- Using the remote control unit
The functions of the remote control for the projector can be switched between service mode (for use by qualified service personnel during setup and adjustment) and normal operation mode (which is used for daily use). If the incorrect mode is set when using the remote control unit, it may be necessary to readjust the projector, so always leave the switch in the battery compartment at the OFF position.
- Do not touch the surfaces of the magnification lenses with your bare hands.
Do not touch the lenses with your bare hands. If the surfaces of the magnification lenses become dirty from fingerprints or anything else, it will impair image quality. Moreover, cover the lenses with the accessory lens caps when not using the projector.
- Take proper care of the screen.
If the screen you are using is dirty, damaged or discolored, attractive projections cannot be obtained. Do not apply any volatile substances to the screen, and do not let it become dirty or damaged.

Before carrying out cleaning and maintenance, be sure to remove the power cord plug from the wall outlet.

■ Wipe the cabinet with a soft, dry cloth.

If the cabinet is particularly dirty, soak the cloth in water with a small amount of neutral detergent in it, squeeze the cloth very well, and then wipe the cabinet. After cleaning, wipe the cabinet dry with a dry cloth.
If using a chemically-treated cloth, read the instructions supplied with the cloth before use.

■ Do not wipe the lenses with a cloth that is dusty or which produces lint.

If any dust or lint gets onto the lenses, such dust or lint will be magnified and projected onto the screen.
Use the blower end of a vacuum cleaner to clean any dust and lint from the lens surfaces, or use a chamois cloth to wipe off any dust or lint.

Clean lenses with a vacuum cleaner or chamois cloth

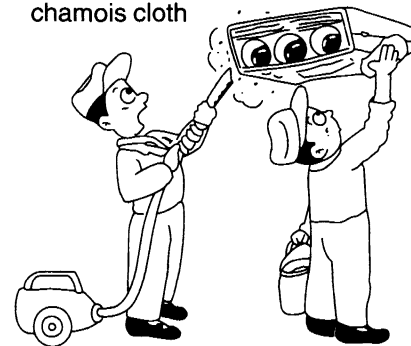

Wipe the cabinet with a soft, dry cloth

We recommend that you use Luminex™ cloth to clean the projector. For details on where you can obtain this cloth, please contact the following.

Toray Marketing & Sales (America), Inc.
600 Third Ave. New York, NY 10016-1901
Tel: (212) 697-8150 Fax: (212) 972-4279

Location of each projector part

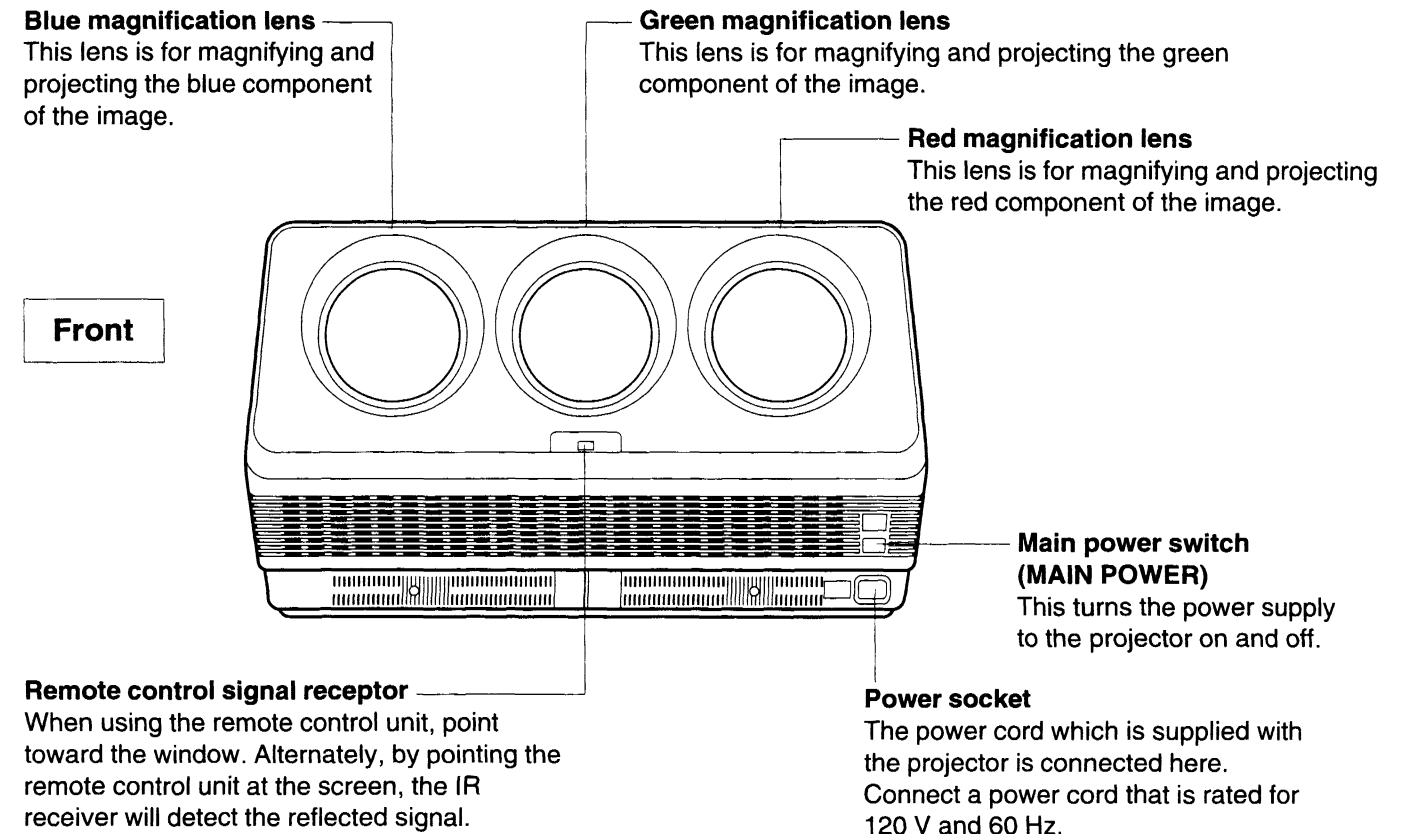

Using the main control panel

Push the placed marked "PUSH", and then open the operation panel cover.

Projecting direction

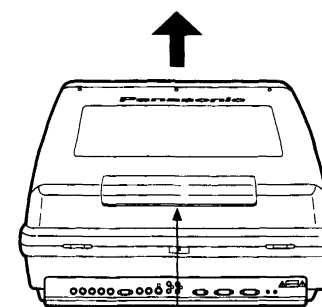

"PUSH" mark

If the power is turned on when the operation panel cover is opened, the operation panel light will illuminate. This makes it easy to see the operation panel when using the projector in dark places.

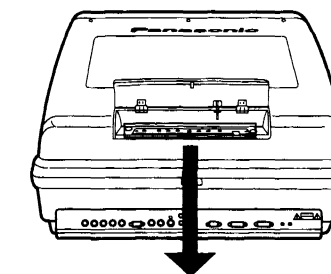

NOTE:

The panel cover can only be opened to an angle of 120°. If you try to open it further than that, the panel cover may be broken.

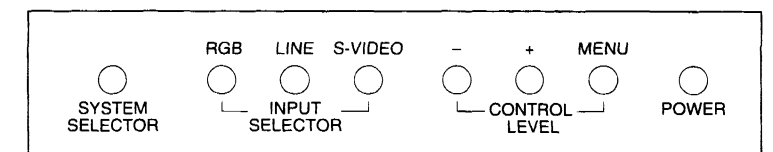

The projector user controls can always be adjusted by using the buttons on the operation panel, even if you don't have the remote control unit with you.

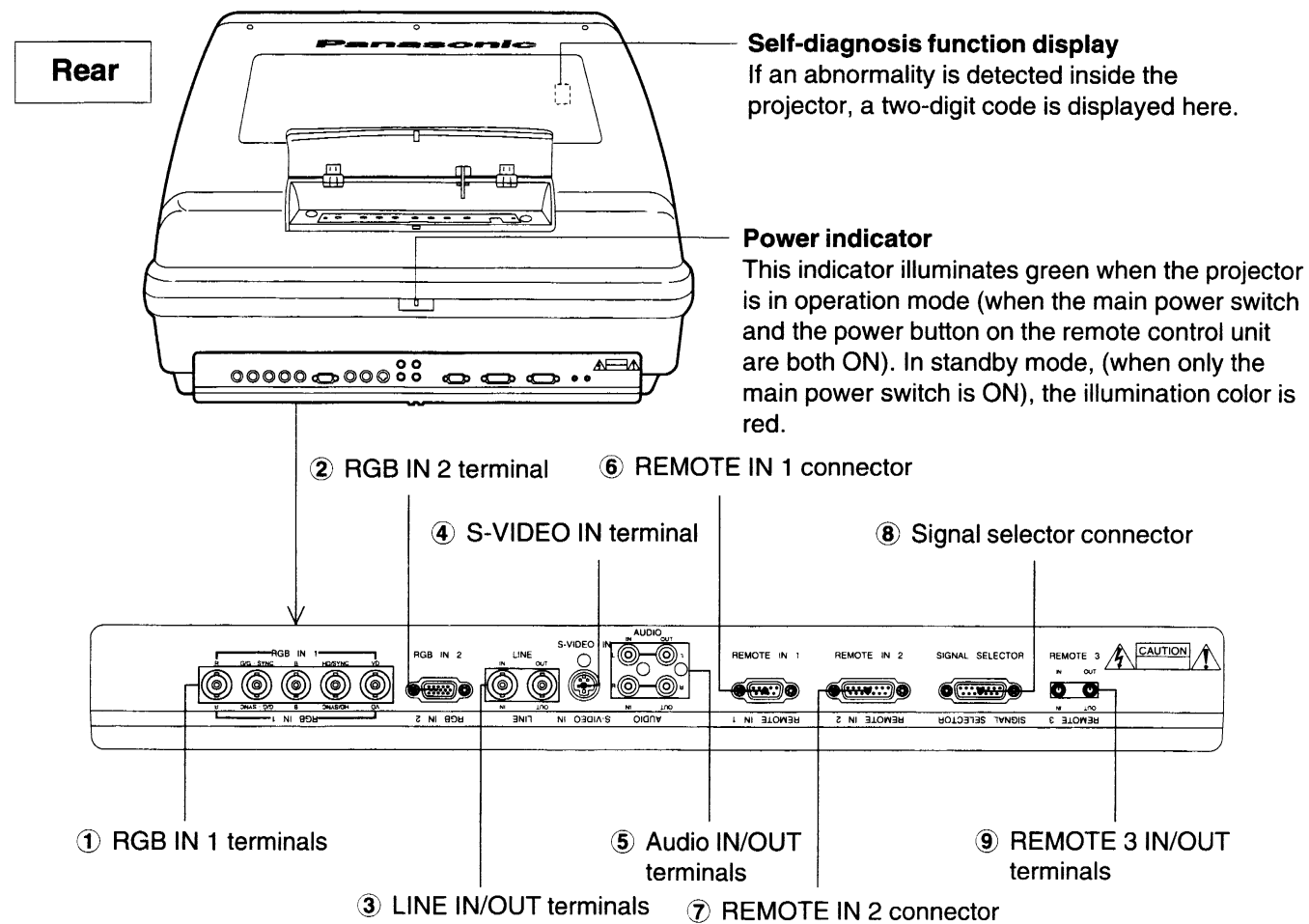

Self-diagnosis function display
If an abnormality is detected inside the projector, a two-digit code is displayed here.

Power indicator
This indicator illuminates green when the projector is in operation mode (when the main power switch and the power button on the remote control unit are both ON). In standby mode, (when only the main power switch is ON), the illumination color is red.

- ① **RGB IN 1 terminals (BNC × 5)**
These terminals are used to input analog RGB signals.
- ② **RGB IN 2 TERMINAL (D-SUB HD15-pin × 1)**
This terminal can be used to input signals directly from a VGA-compatible personal computer, without the need for a video signal interface.
- ③ **LINE IN/OUT terminals (BNC × 2)**
These terminals are used to input and output video signals.
- ④ **S-VIDEO IN terminal (Mini DIN 4-pin)**
This terminal is used to input the Y and C separation signals.
- ⑤ **Audio IN/OUT terminals (RCA × 4)**
These terminals are used to input and output sound in stereo.
The projector remote control unit cannot be used to switch the audio source. Furthermore, the projector is not equipped with built-in speakers.

- ⑥ **REMOTE IN 1 connector (D-SUB 9-pin × 1)**
This connector is used when connecting an external control circuit.
- ⑦ **REMOTE IN 2 connector (D-SUB 15-pin × 1)**
This connector is used when connecting a personal computer in order to make adjustments to the projector during setup. It should only be used by a qualified technician.
- ⑧ **Signal selector connector**
This connector is reserved for use with a signal selector which is to be developed in the future. It cannot be used at the present.
- ⑨ **REMOTE 3 IN/OUT terminals (M3 plug)**
These terminals are used to connect the remote control unit to the projector using the accessory remote control cable.

Location of each remote control unit part

STD (Standard) button
This button is used to reset all of the projector adjustment values (BRIGHT, CONTRAST, TINT, COLOR, SHARPNESS) to the standard setting values.

ESC (Escape) button
This button is used to clear the screen of any characters that are being displayed.

STATUS button
This button is used to display the timing of signals which are being input and to list data that has been recorded.

POWER button
This button is used to turn the power supply for the projector on or to the standby mode.

Input selector buttons
These buttons are used to select the source for input signals received by the projector. It is not possible to switch over the audio signal source.

Numeric buttons
These buttons are used to input the ID number for the remote control.

Control pattern switch
This switch is used to change the functions of some of the remote control keys. It is only for use by a qualified technician, and should always be left at the NORMAL position during ordinary use.

ASPECT button
This switch is used to switch the projector to one of three modes. It is used when setting functions such as the aspect ratio.

ON SCREEN button
This button is used to turn the on-screen display of characters on and off.

SYSTEM SELECTOR button
This button is used to switch in coming video signal between VIDEO and S-VIDEO.

PNR (Picture noise reduction) button
This button is used to turn the picture noise reduction function on and off.

Picture adjustment buttons
These buttons are used to switch the projector to one of the picture adjustment modes (BRIGHT, CONTRAST, COLOR, TINT, SHARPNESS).

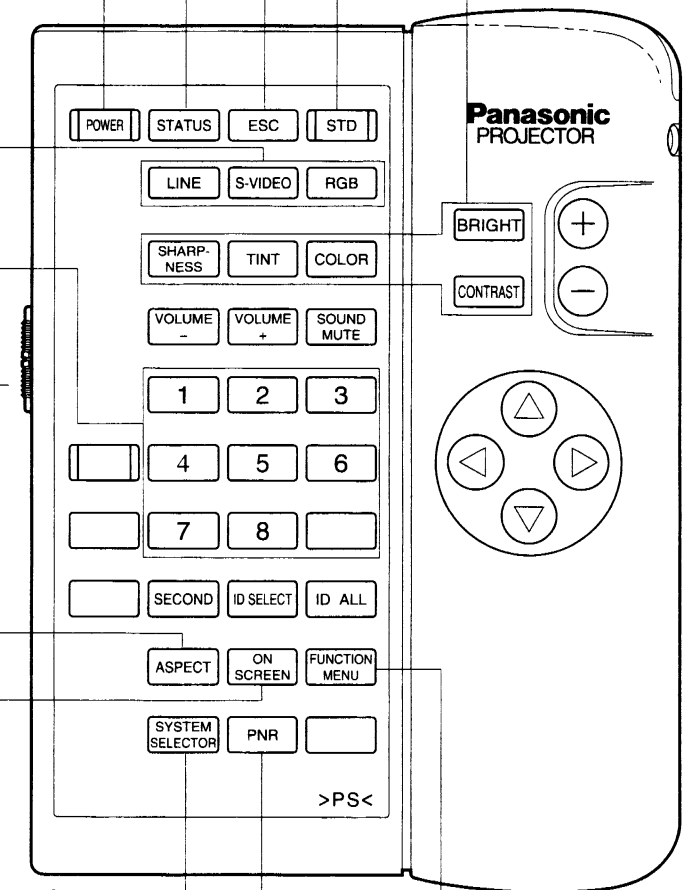

FUNCTION MENU button
This button is used to set the ID number, raster swing, baud rate and V-shift.

VOLUME + and VOLUME - buttons

These buttons are used to control the output level of the signal from the AUDIO OUT terminals.

Transmitter

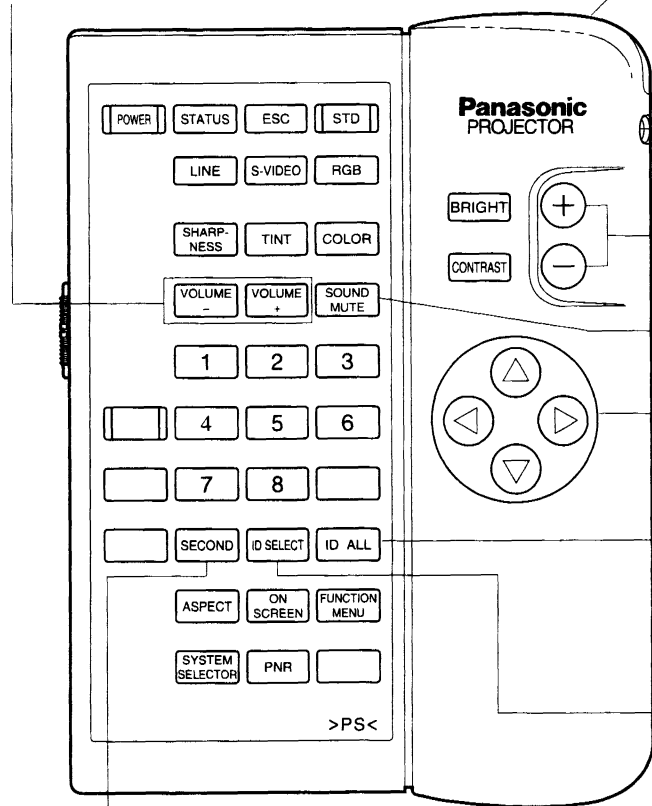

Remote control cable terminal

This terminal is used to connect the accessory remote control cable.

CONTROL LEVEL buttons

These buttons are used to control the adjustment level in any of the picture adjustment modes.

SOUND MUTE button

This button is used to turn off the sound which is being output from the AUDIO OUT terminals.

Arrow buttons

These buttons are used to input adjustment values.

ID ALL button

This button is used to set the ID number of the remote control to ALL.

ID SELECT button

This button is used to record an ID number for the remote control.

SECOND button

This button is reserved for operation of a signal selector which is to be developed in the future. The function of this key changes when the remote control unit is being used by a qualified technician to record signals.

Rear of remote control unit

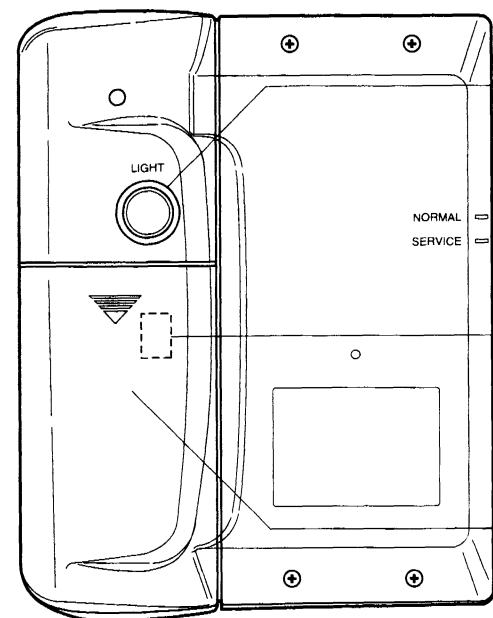

Light button

The buttons on the front of the remote control unit will be illuminated while this button is pressed. The button illumination will switch off approximately ten seconds after this button is released.

Function selection switch

The setting for this switch determines whether the operation mode is changed or not when the service mode switch is operated. It should be left at the OFF position during daily use so that service mode is disabled.

Battery compartment cover

Preparation

Inserting the batteries

- Insert the AA batteries supplied with the remote control unit, making sure that the polarities are correct.
- The batteries also need to be inserted when the remote control unit is connected to the projector using the remote control cable.

1 Open the battery compartment cover.

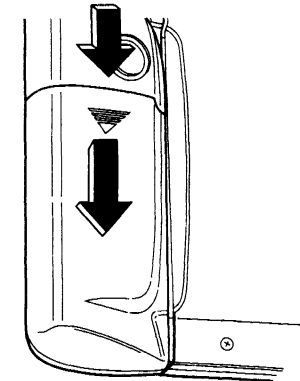

Push the ▼ mark firmly in the direction of the arrow to slide the cover, and then pull it toward you to remove it.

2 Insert the batteries.

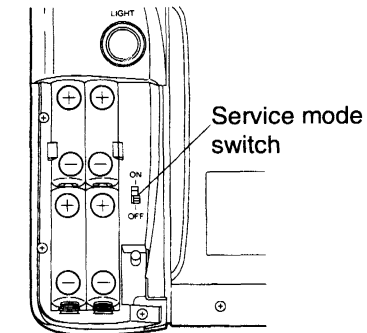

Insert the batteries so that their direction matches the polarity markings inside the compartment.

CAUTION:

- Be sure not to move the function selection switch from the OFF position.

3 Close the battery compartment cover.

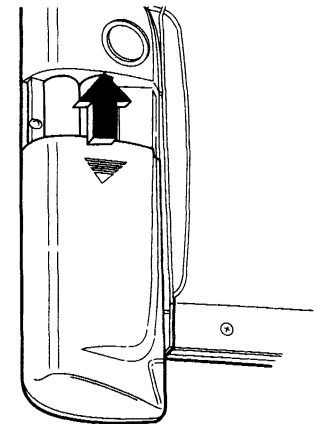

Return the battery compartment cover to its original position.

Notes on using the batteries

The following should be observed in order to prevent damage to or leaking of the batteries.

- Do not mix old and new batteries or batteries of different types.
- Do not recharge the batteries.
- Do not short the (+) and (-) terminals.
- Do not disassemble the batteries.
- Do not burn spent batteries or put them in with combustible garbage.

Notes when using the remote control unit

- Do not spill any liquids onto the remote control unit.
- Do not drop the remote control unit.

If the button illumination starts flashing

When the batteries are nearly spent, the battery check function will cause the button illumination to start flashing when a button is pressed. If this happens, replace the batteries with fresh ones.
* Do not use rechargeable (Ni-Cd) batteries.

Attaching the strap

A strap is provided with the remote control unit. You can use this strap to hang the remote control unit around your neck for easy carrying. Attach the strap as shown in the illustrations below.

1 Open the battery compartment cover.

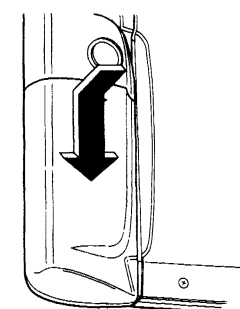

2 Attach the supplied strap as shown in this illustration.

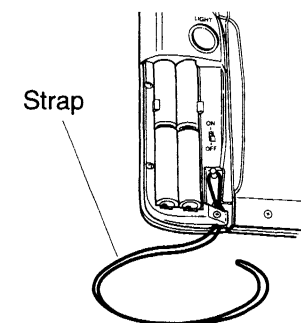

3 Close the battery compartment cover.

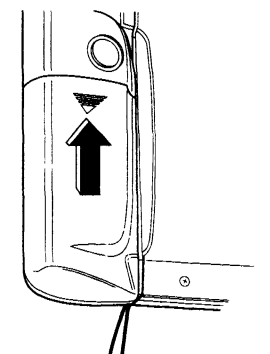

Using the remote control unit without the cable

To use the remote control unit without connecting it to the projector, point the transmitter of the remote control unit toward the remote control signal receptor of the projector or the screen and press the buttons on the remote control unit.

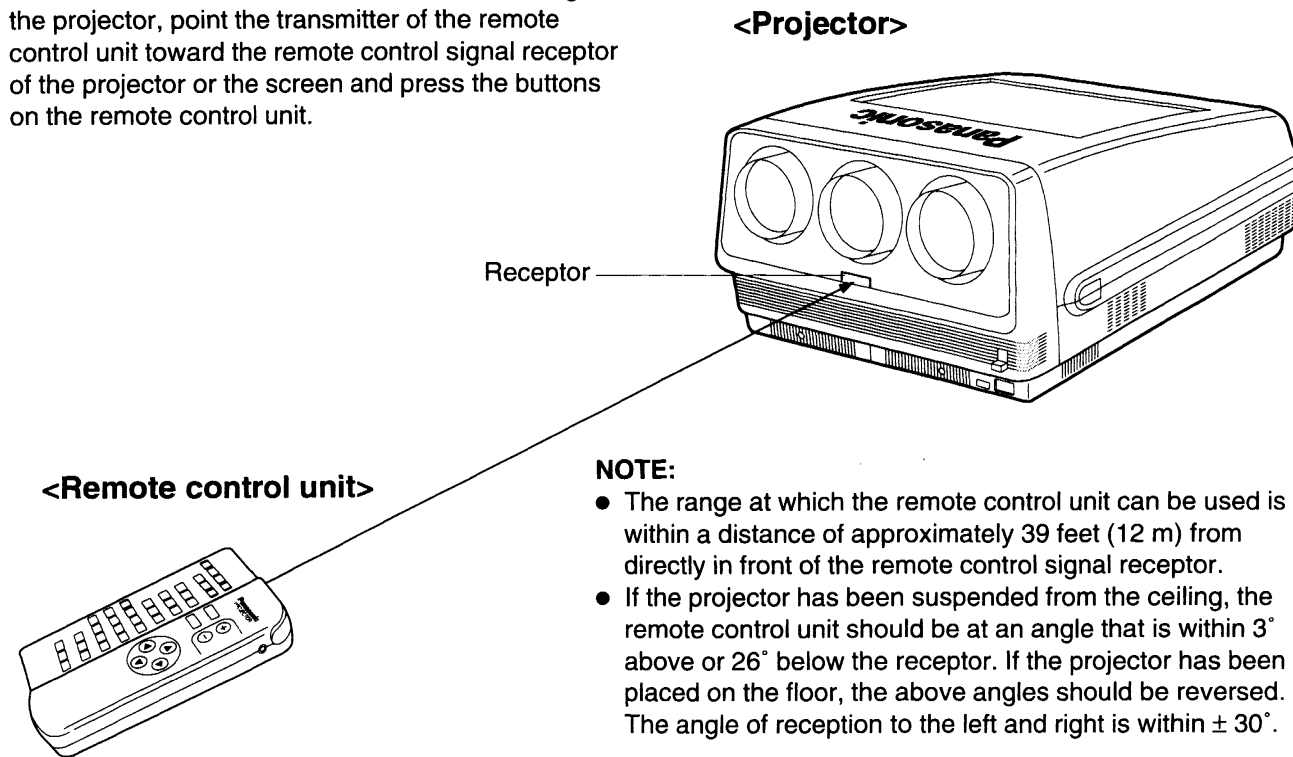

NOTE:

- The range at which the remote control unit can be used is within a distance of approximately 39 feet (12 m) from directly in front of the remote control signal receptor.
- If the projector has been suspended from the ceiling, the remote control unit should be at an angle that is within 3° above or 26° below the receptor. If the projector has been placed on the floor, the above angles should be reversed. The angle of reception to the left and right is within ± 30°.

Connecting the remote control unit to the projector

The remote control unit can be connected to the projector using the accessory remote control cable. This cable should be connected to the REMOTE 3 IN terminal at the rear of the projector and to the remote control cable terminal.

NOTE:

- The maximum length for the cable used to connect the remote control unit is 49 feet (15 m).

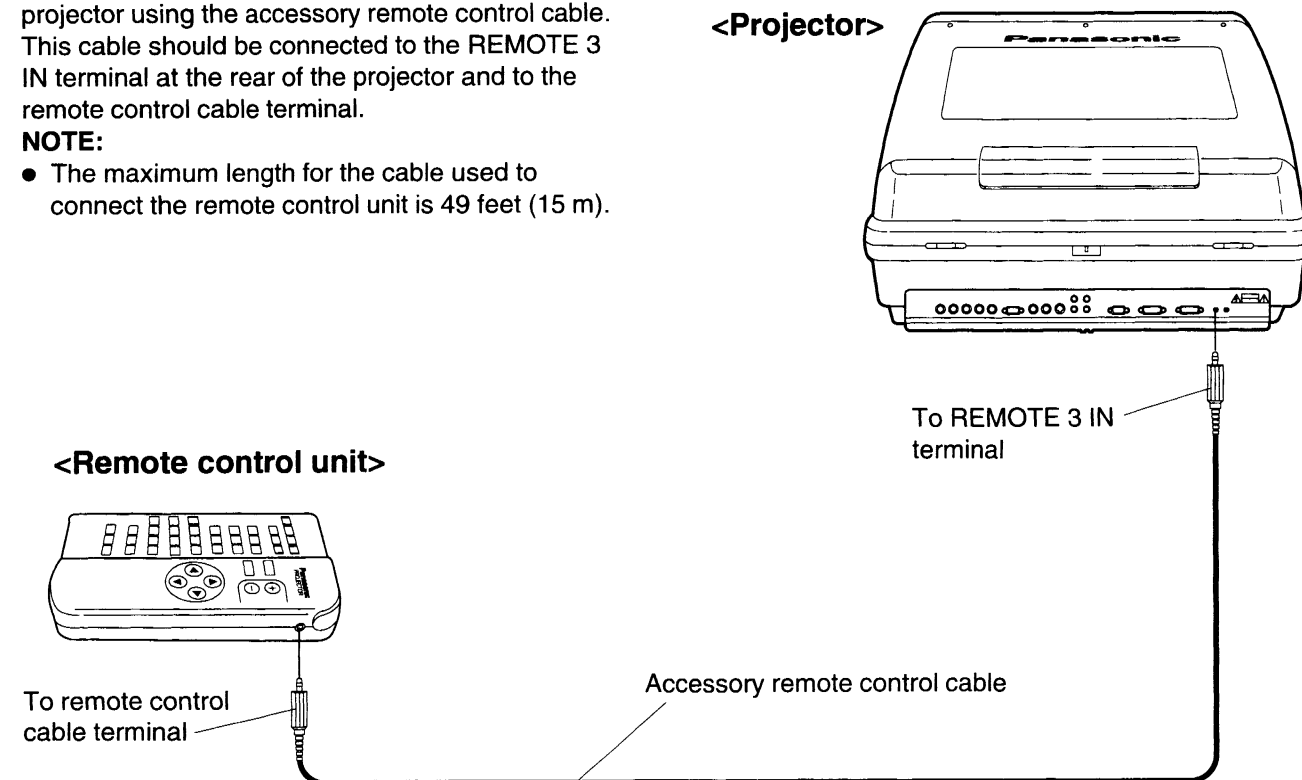

Controlling two or more projectors

If using two or more projectors at the same time, you can control each projector individually or all projectors at once by programming each projector with an ID number.

Setting ID numbers

ID numbers are set from the Function menu. You can set the ID number of each unit to a number from 1 to 8.

The projector is operated by the following procedure.

1. Set the ID number of the remote control unit to ALL.
Press the ID ALL button on the remote control unit.

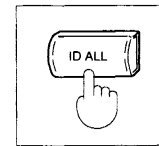

2. If using two or more projectors together at the same time, use the remote control unit in one of the ways shown below so that projectors other than the one you currently wish to use will not be operated.

- Bring the remote control unit close to the remote control signal receptor of the unit you wish to operate.

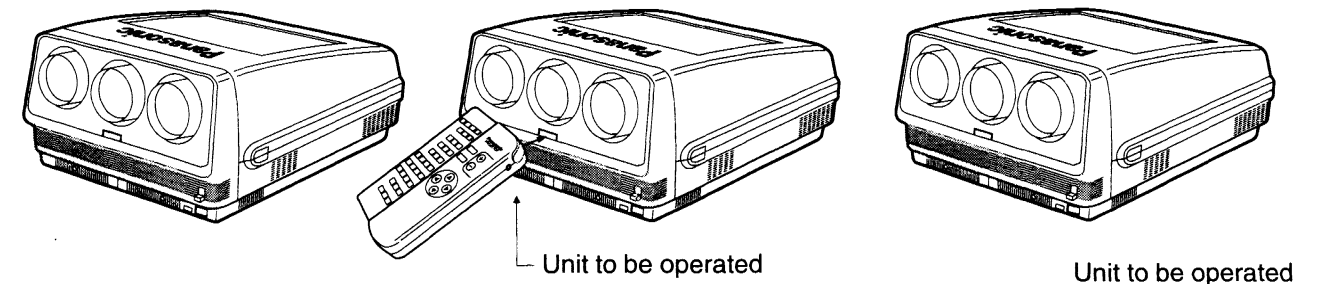

- Use the remote control cable to connect the remote control unit to the unit to be operated.

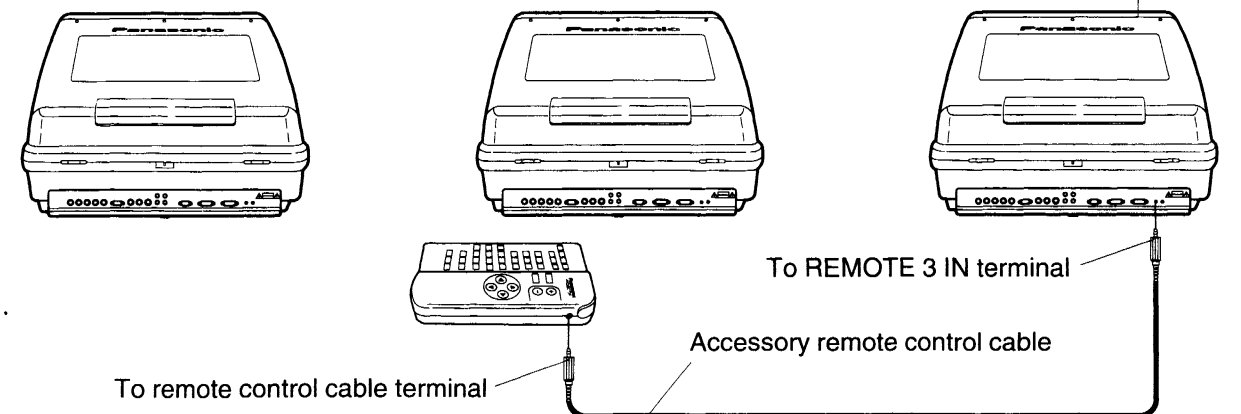

- Turn off the power for all units other than the unit you wish to operate.

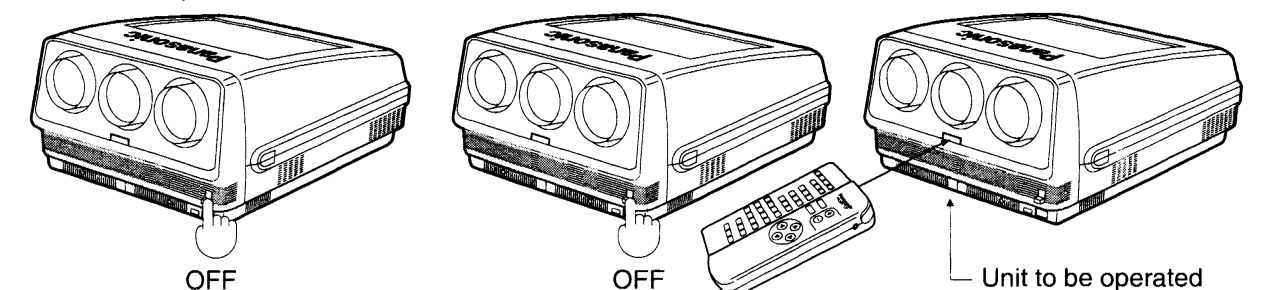

3. Setting function mode

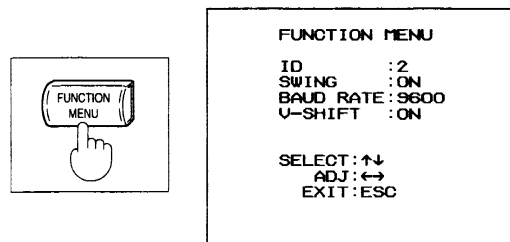

Press the FUNCTION MENU button on the remote control unit.

NOTE:
The V-SHIFT item will not be displayed while the projector is receiving a LINE/S-VIDEO signal.

4. Use the arrow keys to change the ID number.

Use the up or down key to select "ID", and then use the left and right keys to set the number. The number changes as shown below each time a key is pressed.

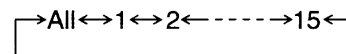

However, the remote control unit can only be used to set projector ID numbers from 1 to 8. If a qualified technician is using a personal computer to make the settings, it is possible to use the personal computer to set further ID numbers from 9 to 15. If the projector ID number is set to "ALL", then that projector can be operated irrespective of which ID number is selected on the remote control unit. If you would like all projectors to operate together, set the ID numbers to "ALL"

ID No.	Remote control unit	Personal computer
1 } 8	Operation possible	Operation possible
9 } 15	Operation not possible	

5. Once the desired ID number is displayed, press the ESC button to record that number and return to the normal screen.

CAUTION:

- Once you have set the ID number for a projector, you will need to specify that ID number on the remote control unit before use, otherwise the remote control unit will not be able to operate that projector. For details on the method of operation, refer to "Using the ID function" on page 26.
- The V-SHIFT item will not be displayed while the projector is receiving a LINE/S-VIDEO signal.

NOTE:

- The remote control unit can be used with the remote control cable connected or disconnected.
- Any number of projectors can be controlled by the remote control unit using ID numbers. All projectors which have been recorded with the same ID number will operate when that ID number is selected. A maximum of 8 such ID numbers that can be set by means of the remote control unit, using the numbers from 1 to 8.
- If using this method with the remote control unit connected to a projector by means of the remote control cable, use the REMOTE 3 IN/OUT terminals to connect the respective projectors as shown in the illustration below.

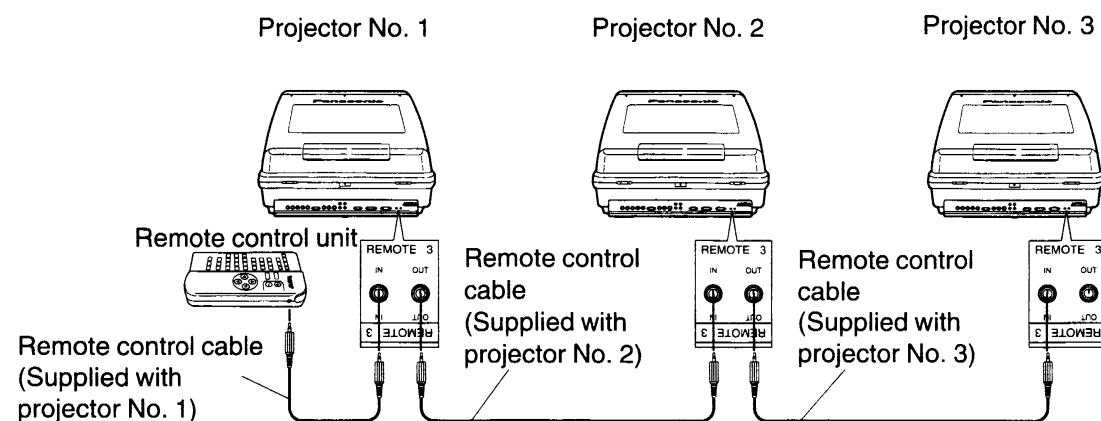

Operating the projector

Turning the main power on and off

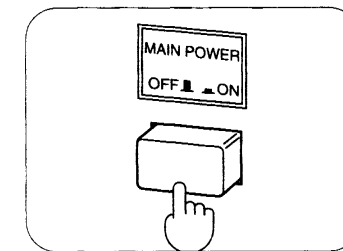

Press the main power switch at the front of the projector. When the main power is turned on, the projector will go to the standby condition and the power indicator at the rear of the projector will illuminate red. The POWER buttons on the remote control unit and on the operation panel can be used to turn the power on and off when the projector is in the standby condition.

NOTE:

If the main power switch is turned to off and then back to on when the power has already been turned on (when light is being projected onto the screen), the projector will go directly to the operation condition without going to the standby condition. Furthermore, if the main power switch is turned off in the standby condition, the power indicator will continue to illuminate for approximately 13 seconds before switching off.

Turning the power on and off

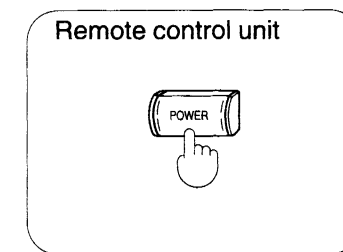

or

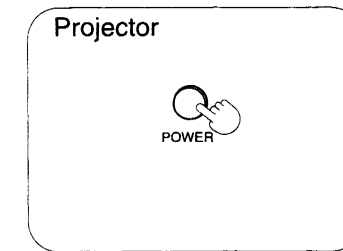

When the projector is in the standby condition (when the main power switch has been turned on), press the POWER button on the remote control unit or on the operation panel to turn the power on. The power will toggle on and off each time this button is pressed.

When the power is turned on, the projector will change to operation mode and the power indicator will illuminate green. Furthermore, the name of the input signal terminal (RGB 1, RGB 2, LINE, S-VIDEO), the signal's format (AUTO, NTSC, M-NTSC, PAL SECAM) and the ID number recorded for that projector (1-15) will be displayed on the screen. Note however that the signal's format will only be displayed when the input terminal is LINE or S-VIDEO.

NOTE:

- The power can also be turned on and off using an external control circuit which is connected to the REMOTE IN 1 connector at the rear of the projector. For details, refer to "Using the REMOTE IN 1 connector" on page 27.
- If the ID number of the projector has been set to "ALL", the ID number will not be displayed.

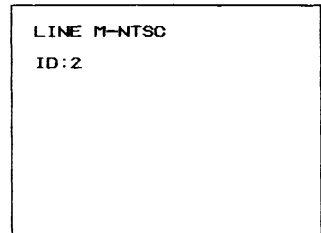

Caution message displays

If horizontal or vertical scanning signals which are outside the projector's specified frequency range are received or no signal is being input, or if an invalid button is pressed in any mode, either one of the following messages will be displayed on the screen. If this occurs, check the equipment which has been connected to the projector or carry out the correct operation.

- When no signal is input or the signal input is outside the frequency range

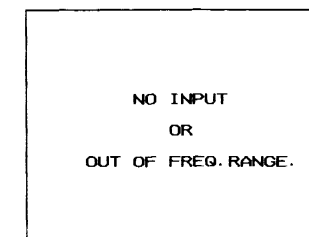

- When an invalid button is pressed

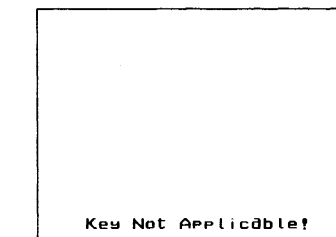

Selecting the input

Press the input selector buttons (RGB, LINE, S-VIDEO) on the projector or on the remote control unit.

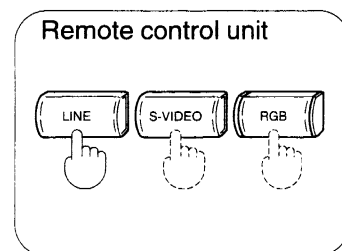

- **RGB button**
This button is used to receive the RGB signal input from the device which is connected to the RGB IN 1 or RGB IN 2 terminals. Input is toggled between RGB IN 1 and RGB IN 2 each time this button is pressed.
- **LINE button**
This button is used to receive the video signal input from the device which is connected to the LINE IN terminal.
- **S-VIDEO button**
This button is used to receive the Y/C separation signal input from the device which is connected to the S-VIDEO IN terminal.

or

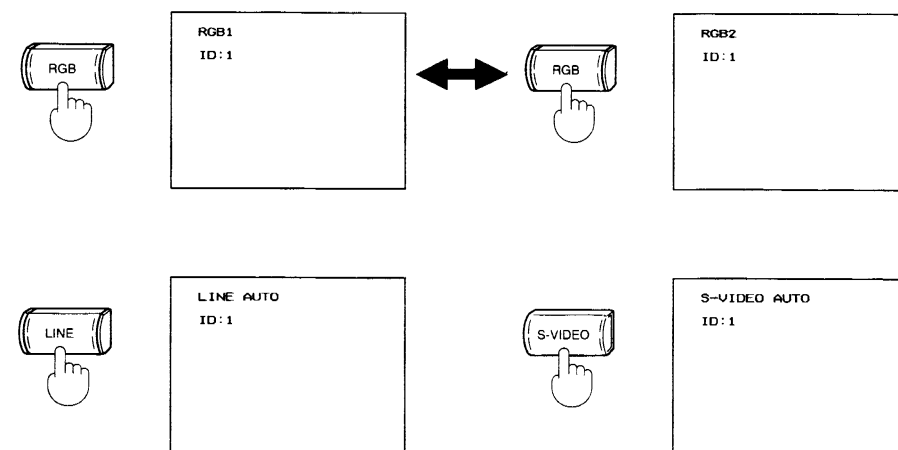
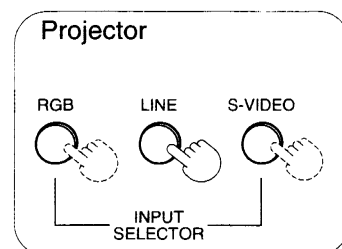

Changing the system format

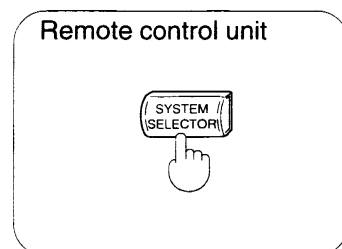

or

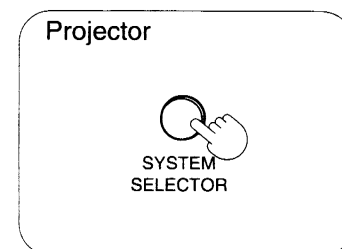

The SYSTEM SELECTOR buttons on the remote control unit and projector can be used to switch the projector circuits to match the format of the signal which is being input from the device connected to the LINE or S-VIDEO input terminals.

Each time one of the buttons is pressed, the format changes in the order "AUTO" → "NTSC" → "M-NTSC" → "PAL" → "SECAM", and the current format setting is displayed on the screen. This on-screen display is cleared approximately ten seconds after the button is released.

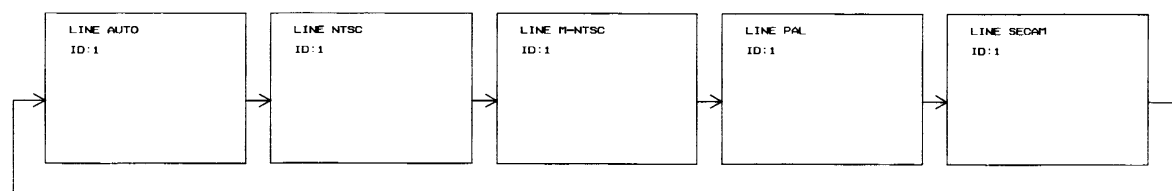

- Signals of any format can usually be received if the system format is set to "AUTO". However, for sources with poor video signal quality, such as copied tapes, normal signal reception may not be possible. In such cases, switch the system selector to the applicable format.
- The system format cannot be switched while RGB signals are being received.

Adjusting the picture quality

1. Selecting a picture adjustment mode

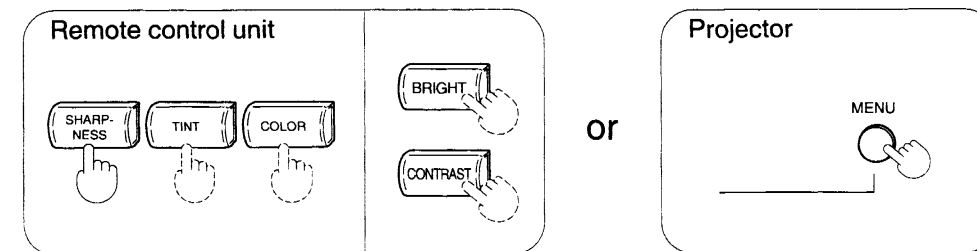

A picture adjustment mode can be selected by pressing the MENU button on the projector or the BRIGHT, CONTRAST, COLOR, TINT or SHARPNESS buttons on the remote control unit. Approximately 10 seconds after one of these buttons is pressed, the screen display will be cleared.

- When using the remote control
Press the button which corresponds to the mode you wish to adjust.
- When using the projector operation panel
Keep pressing the MENU button until the desired item appears on the screen. The items change in the order shown below.

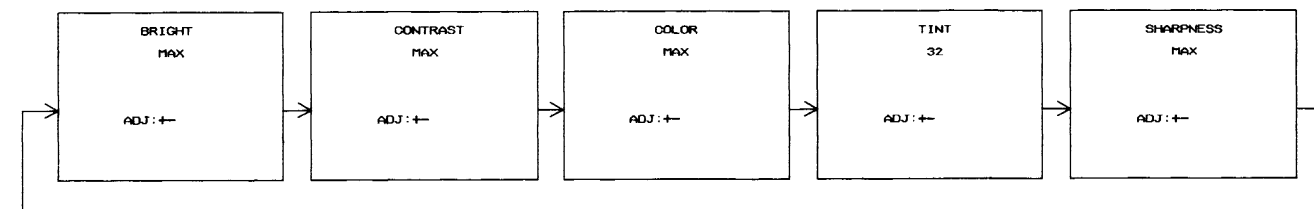

NOTE:

- Some modes may not be able to be adjusted depending on the signal being received. Refer to the table below for a guide to such cases.

SIGNAL SYSTEM		MODE	BRIGHT	CONTRAST	COLOR	TINT	SHARPNESS
RGB1 / RGB2			○	○	×	×	×
VIDEO	PAL/SECAM		○	○	○	×	○
	S-VIDEO NTSC/M-NTSC		○	○	○	○	○

2. Adjust using the CONTROL LEVEL buttons.

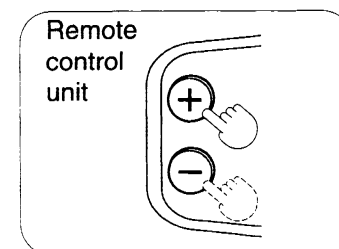

or

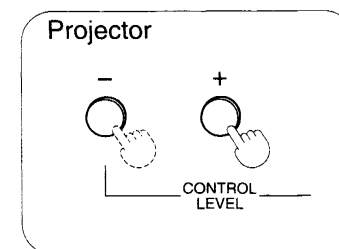

When the projector is in a picture adjustment mode, the setting level for that mode can be changed by pressing the "+" and "-" CONTROL LEVEL buttons. The setting level for each mode can also be adjusted separately for each input signal, and all adjustment settings are stored by the projector.

- If the button is pressed continuously, the values in the on-screen display will also change continuously. Keep pressing the button while watching the picture until the desired adjustment level is reached, and then release the button. The on-screen display will be cleared approximately 10 seconds after the button is released.
- Refer to the following page for details of each adjustment mode.
- If the "+" or "-" CONTROL LEVEL buttons on the unit are pressed while the projector is not in adjustment mode, the projector will switch to volume adjustment mode. Refer to "Controlling the volume" on page 23 for details on how to adjust the volume.

Brightness adjustment mode

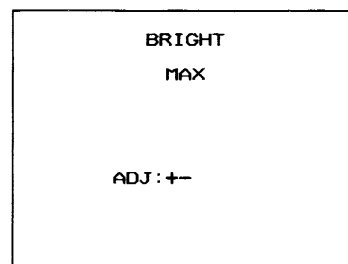

This mode lets you adjust the brightness of the picture.
If the "+" button is pressed continuously, the picture images become brighter.
If the "-" button is pressed continuously, the picture images become darker.

The value can be changed within a range of 0 to 255. The minimum value appears on the screen as "MIN" and the maximum value appears as "MAX".

Contrast adjustment mode

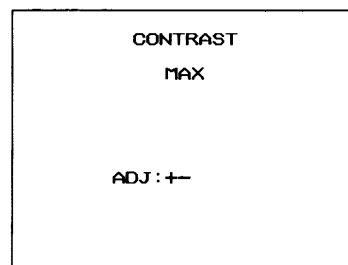

This mode lets you adjust the contrast of the picture.
If the "+" button is pressed continuously, the color contrast is increased.
If the "-" button is pressed continuously, the color contrast is decreased.

The value can be changed within a range of 0 to 255. The minimum value appears on the screen as "MIN" and the maximum value appears as "MAX".

Color adjustment mode

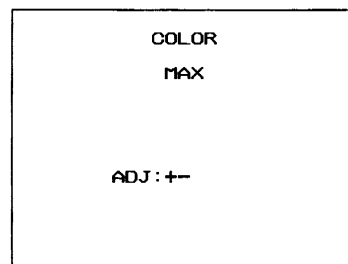

(Color adjustment is unnecessary when RGB signals are being received, so color adjustment mode will be disabled in this input mode.)

This mode lets you adjust the density of the picture color.
If the "+" button is pressed continuously, the color intensity increases.
If the "-" button is pressed continuously, the color intensity decreases.

The value can be changed within a range of 0 to 63. The minimum value appears on the screen as "MIN" and the maximum value appears as "MAX".

Tint adjustment mode

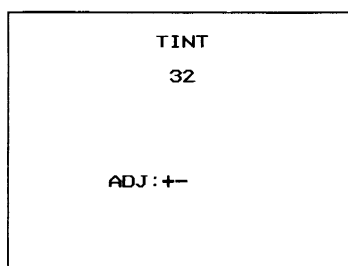

(Tint adjustment is unnecessary when RGB, PAL and SECAM signals are being received, so tint adjustment mode will be disabled at this time.)

This mode lets you adjust the tint of the picture color.
If the "+" button is pressed continuously, flesh tones tend to become greenish.
If the "-" button is pressed continuously, flesh tones tend to become reddish.

The value can be changed within a range of 0 to 63. The minimum value appears on the screen as "MIN" and the maximum value appears as "MAX".

Sharpness adjustment mode

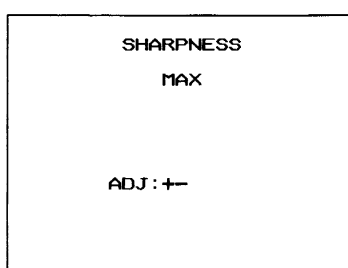

(Sharpness adjustment is unnecessary when RGB signals are being received, so sharpness adjustment mode will be disabled at this time.)

This mode lets you adjust the sharpness of the picture quality.
If the "+" button is pressed continuously, the picture images become sharper.
If the "-" button is pressed continuously, the picture images become softer.

The value can be changed within a range of 0 to 255. The minimum value appears on the screen as "MIN" and the maximum value appears as "MAX".

Resetting picture adjustments to default settings

The projector is provided with a function that returns all picture adjustment settings (BRIGHT, CONTRAST, COLOR, TINT, SHARPNESS) to their default settings (shown in the table below). The method of doing this is explained below.

● Standard values for each setting

BRIGHT	CONTRAST	COLOR	TINT	SHARPNESS
128	190	32	32	32

1. Select the signal.
Press the INPUT SELECTOR button on the remote control unit or on the projector operation panel to select the desired signal. (Refer to "Selecting the input" on page 17.)
2. Select the adjustment mode.
Press the MENU button on the projector or one of the picture adjustment buttons (BRIGHT, CONTRAST, COLOR, TINT or SHARPNESS button) on the remote control unit.
3. Press the STD (standard) button.
Press the STD (standard) button within 10 seconds after the projector switches to adjustment mode. When the button is pressed, the displayed value will change to the corresponding value shown in the above table. The on-screen display will then be cleared approximately 6 seconds after the button is released.

Example: To return the contrast setting to the standard setting

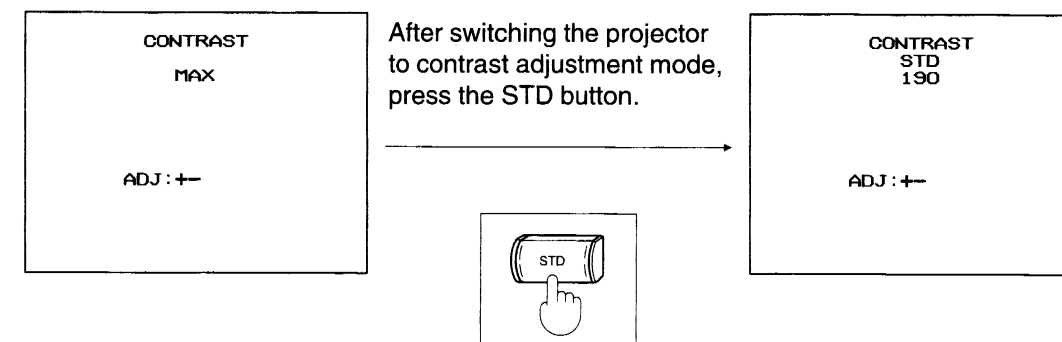

NOTE:

- If the STD button is not pressed within 10 seconds after the projector switches to the adjustment mode, the on-screen display will be cleared and changing the setting will not be possible.

Viewing the status and recorded data for input signals

When the STATUS button on the remote control unit is pressed, the projector will display a table of the status of each signal which is currently being received by the projector, as well as a listing of the data that has been recorded by the projector. The details shown are different when RGB signals are being received and when LINE/S-VIDEO signals are being received. The on-screen display will then be cleared approximately 10 seconds after the STATUS button is released. If you would like to clear the display more quickly, press the ESC button on the remote control unit.

- The screen display will change each time the STATUS button is pressed. However, screens (2) and (3) shown below will only appear when an RGB signal is being received. Furthermore, screen (1) shows the display when a RGB signal is being received. The screen displayed when LINE/S-VIDEO signals are being received is slightly different from this screen.

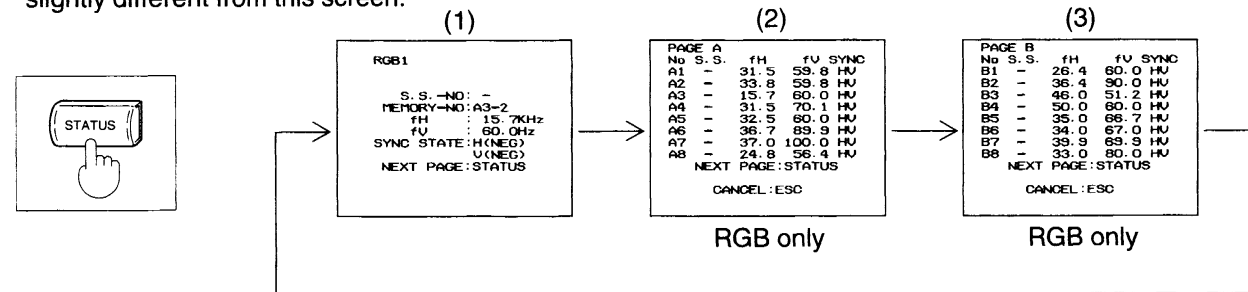

About each status screen

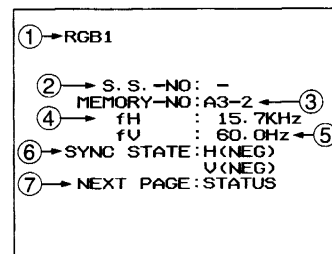

- Signal name (RGB 1, RGB 2, LINE, S-VIDEO) and signal format (AUTO, NTSC, M-NTSC, PAL, SECAM)
- When a signal selector (scheduled for future release) is connected, the number of the signal selector will be displayed here.
- Varies depending on whether RGB or LINE/S-VIDEO signals are being received.
 - For RGB
MEMORY-NO: A3 - 2 ← "A3" indicates the location where the signal which is currently being received is stored. (A1~A8, B1~B8)
"2" indicates the aspect number (1~3). Refer to "ASPECT button" on page 22.
 - For LINE/S-VIDEO
ASPECT-NO: 2 ← "2" indicates the aspect number (1~3). Refer to "ASPECT button" on page 22.
- Horizontal synchronizing frequency
- Vertical synchronizing frequency
- Synchronizing frequency type and characteristics
 "-" When LINE/S-VIDEO signals are being received
 H Horizontal component of separation signal
 V Vertical component of separation signal
 C Composite sync signal
 "POS" Synchronizing signal has positive polarity (red).
 "NEG" Synchronizing signal has negative polarity (blue).
 "G" SYNC ON G (Refer to ⑥ above.)
- Not displayed when LINE/S-VIDEO signal is being received.
- Page (A/B)
- Address No. (A1~8, B1~8)
- When a signal selector (scheduled for future release) is connected, the number of the signal selector will be displayed here.
- Horizontal synchronizing frequency
- Vertical synchronizing frequency
- Synchronizing frequency type and characteristics
 C Composite sync signal } Positive polarity: Shown in red
 HV ... Separation signal } Negative polarity: Shown in blue
 G SYNC ON G (Refer to ⑥ above.)

9 → No
10 → S.S.
11 → fH
12 → fV
13 → SYNC

Address	fH	fV	SYNC
A1	31.5	59.8	HV
A2	33.8	59.8	HV
A3	15.7	60.0	HV
A4	31.5	70.1	HV
A5	32.5	60.0	HV
A6	36.7	89.9	HV
A7	37.0	100.0	HV
A8	24.8	56.4	HV

NEXT PAGE: STATUS
CANCEL: ESC

ASPECT button

The projector can store three different signal settings (including settings for the aspect ratio, for example) for each input signal, and it is possible to switch between these settings by pressing the ASPECT button. However, only the No. 1 aspect memory (aspect ratio 4:3) is set at the time of shipment from the factory. (The settings for the No. 1 aspect memory mode are: ceiling mounting, RGB signal with fh = 31.5 kHz and fv = 60 Hz, with the four types of LINE and S-VIDEO signals recorded. In addition, the aspect ratio is set to 4:3 and the color temperature is set to MID.)

The following settings can be made for each mode.

- Aspect ratio
- Color temperature
- Image center position
- Raster linearity adjustment
- Blanking adjustment
- White balance adjustment
- Convergence adjustment
- Clamp position setting

Consult a qualified technician if you would like to use any of these functions.

Example:

If the aspect ratios have been set to "4:3/16:9/7.1:3" for each mode, the screen aspect ratio will change as shown below each time this key is pressed.

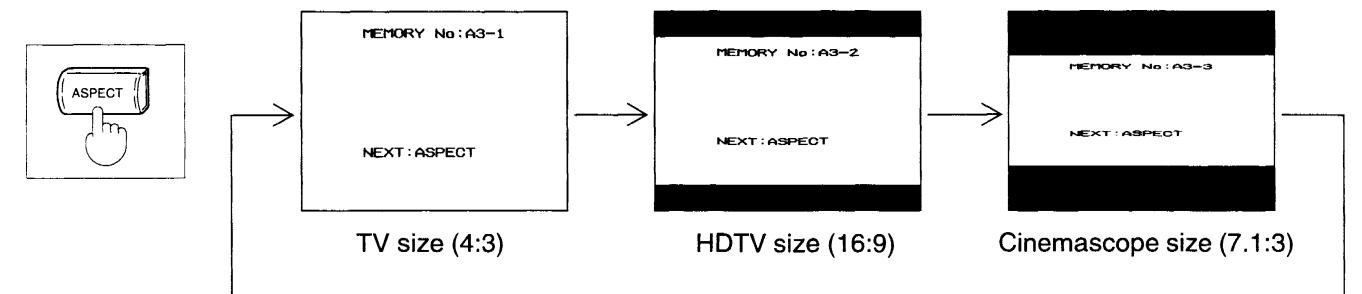

- When this button is pressed once, the memory address number is displayed on the screen. During this time, the number changes each time the button is pressed again.
- "ASPECT NO." is displayed when the projector is receiving LINE/S-VIDEO signals.
- If memory address No. 2 and 3 have not been assigned, the memory address number will not change when the ASPECT button is pressed.

NOTE:

- Assigning memory addresses should only be carried out by a qualified technician. Consult the qualified technician during setting-up and adjustment.
- The on-screen display will be cleared approximately 10 seconds after the ASPECT button is released.

Controlling the volume

It is possible to adjust the volume of the sound which is output from the AUDIO OUT terminals of the projector.

● Adjusting the volume

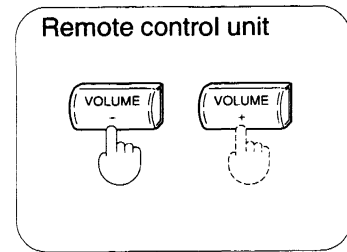

If the VOLUME + or VOLUME - buttons on the remote control unit are pressed, the projector will switch to volume adjustment mode. It will also switch to this mode if the CONTROL LEVEL "+" or "-" buttons on the operation panel are pressed when the projector is not in a picture adjustment mode. If one of these buttons is pressed continuously while in volume adjustment mode, the volume setting will change as displayed on the screen.

If the "+" button is pressed continuously, the volume will become louder. If the "-" button is pressed continuously, the volume will become softer.

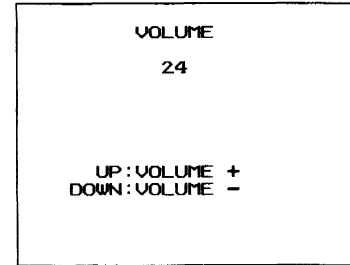

The value can be changed within a range of 0 to 63. The minimum value appears on the screen as "MIN" and the maximum value appears as "MAX".

The on-screen display will be cleared approximately 10 seconds after the button is released.

NOTE:

- The projector is not equipped with built-in speakers, so you will need to connect an external amplifier and speakers.
- The audio source for the projector cannot be changed.

or

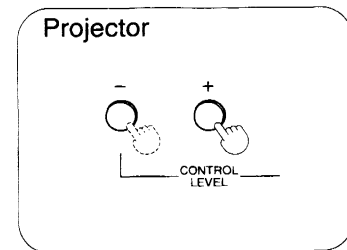

● Turning off the sound

The sound can be turned on and off by pressing the SOUND MUTE button on the remote control unit.

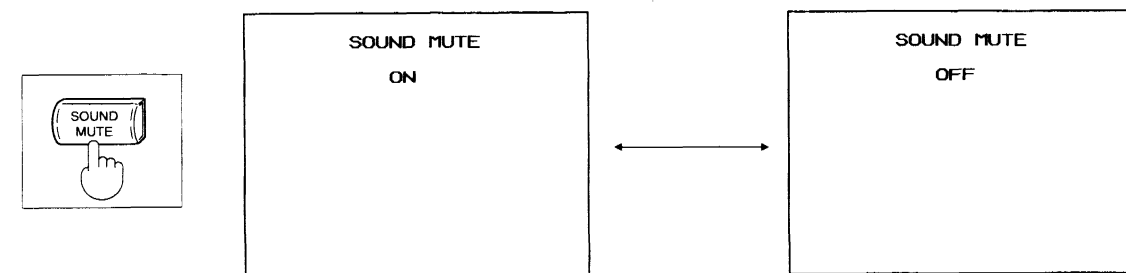

When the SOUND MUTE setting is ON, no sound is output.
When the SOUND MUTE setting is OFF, sound is output.

- If the sound has been turned off by switching the MUTE setting to OFF, it will turn back on again if you press the VOLUME "+" or VOLUME "-" button on the remote control unit or a CONTROL LEVEL key on the operation panel.

NOTE:

- The projector is not equipped with built-in speakers, so you will need to connect an external amplifier and speakers.
- The audio source for the projector cannot be changed.

Turning the on-screen display function on and off

The on-screen display of characters can be turned on and off each time the ON SCREEN button is pressed.

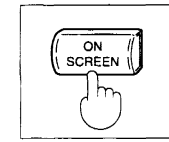

When on-screen character display is turned on, all of the modes which are given in this instruction manual are displayed when the corresponding remote control unit or operation panel buttons are pressed.

- The input signal name (RGB1, RGB2, LINE, S-VIDEO) and the signal format (AUTO, NTSC, M-NTSC, PAL, SECAM) will be displayed on the screen 10 seconds after the power of the projector is first turned on.

When on-screen character display is turned off, none of the modes which are given in this instruction manual are displayed when a button is pressed.

- However, if a new signal which has not been previously recorded during setup and installation is input and the power for the projector is turned on, the name of this signal will be displayed.

NOTE:

When the ON SCREEN button is pressed, nothing will appear on the screen to show that on-screen display has been turned on or off.

Using the picture noise reduction function

(This function is only valid when LINE or S-VIDEO signals are being received.)

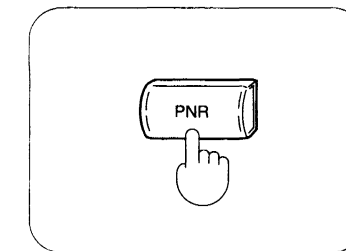

This projector is provided with a picture noise reduction function which corrects scattered interference that may appear in the picture image.

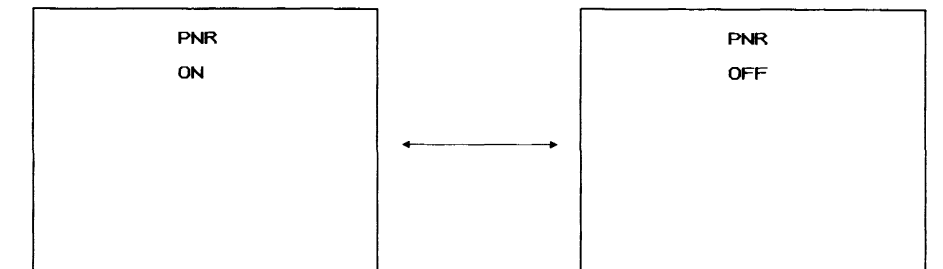

- You can check whether the PNR function has been activated or not by pressing the PNR button on the remote control unit to display the function setting status on the screen. While the PNR function setting status is being displayed, it can be changed from on to off and back again each time the PNR button is pressed.

When the PNR function is on, the correction circuit will operate. When the PNR function is off, the image is processed normally, so dotted patterns such as that shown in the illustration at right might appear in the picture.

NOTE:

The on-screen display will be cleared approximately 10 seconds after the button is released.

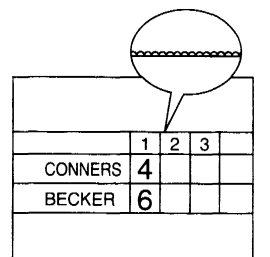

Function menu





The following settings can be made from the function menu.

- **ID**
This item sets the ID number for the projector. For further details, refer to “Setting ID numbers” on page 14.
- **RASTER SWING**
This item is used to turn the raster swing function on and off. The purpose of the raster swing function is to prevent burn-in from occurring with the picture tube when a still or paused picture is displayed for a long period of time. If the function is set to on, the horizontal and vertical positions of the picture are varied little by little in a random sequence. However, if two or more the projectors (dual-type projectors, etc.) are being used together, this will cause the projected images to become misaligned, so in such cases this function should be set to off.
- **BAUD-RATE**
This item is used to set the data transmission speed for the REMOTE IN 2 connector. This setting is used by a qualified technician when a personal computer is connected to the REMOTE IN 2 connector of the projector in order to carry out setting adjustments.
- **V-SHIFT**
This item is used by service personnel to adjust the vertical shift and centering of the projected images.

Operation procedure

Follow the instructions below to make these settings.

1. Follow the procedure given in steps 1~3 on pages 14 and 15 to display the function menu on the screen.
2. Press the arrow keys on the remote control unit to adjust the settings.

-   Use the up and down keys to select the item to be adjusted.
 (The item which is highlighted is the one that is currently selected.)
-   Use the left and right keys to adjust the setting for the selected item.
 Each item's setting changes as shown below each time one of these keys is pressed.

ID	→All←1←2←-----15←
SWING	ON ↔ OFF
BAUD RATE	→1200←2400←4800←9600←
V-SHIFT	ON ↔ OFF

3. Returning to the normal screen

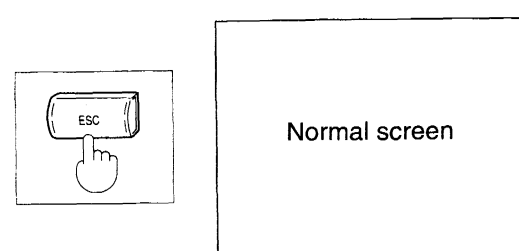

Press the ESC button on the remote control unit. The current setting will be recorded and the display will return to the normal screen.

4. Set the ID number of the remote control unit back to the original ID number.
(Refer to “Using the ID function” on page 26 for instructions on how to do this.)

Using the ID function

In systems where several projectors are being used at the same time, the different projectors can be controlled either individually or all simultaneously using the same remote control unit if ID numbers have been set for each projector as explained in “Setting ID numbers” on page 14. Up to eight different ID numbers can be set with the remote control unit, but two or more projectors can be assigned the same number. In such cases, projectors with the same ID number will operate simultaneously when that number is selected. Furthermore, when using only a single projector, you can set an ID number to ensure that the projector cannot be used unless the ID number is specified.

Controlling all projectors simultaneously

All projectors can be controlled simultaneously by pressing the ID ALL button.

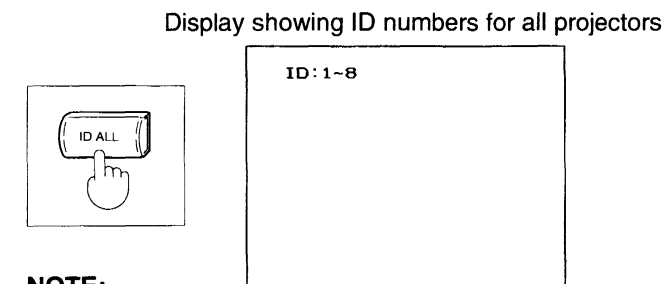

NOTE:

- If no ID numbers have been set, “ID:0” will be displayed.
- The on-screen display will be cleared approximately 10 seconds after the ID ALL button is pressed.
- After this setting has been made, all projectors can be controlled at the same time with a single operation of the remote control unit.

Controlling specified projectors individually

Press the ID SELECT key, and then press a number from 1 to 8 corresponding to the ID number for the projector you wish to operate. The designated projector can then be operated, and projectors with non-designated ID numbers will not operate.

Example: To control the projector which has its ID number set to “3”

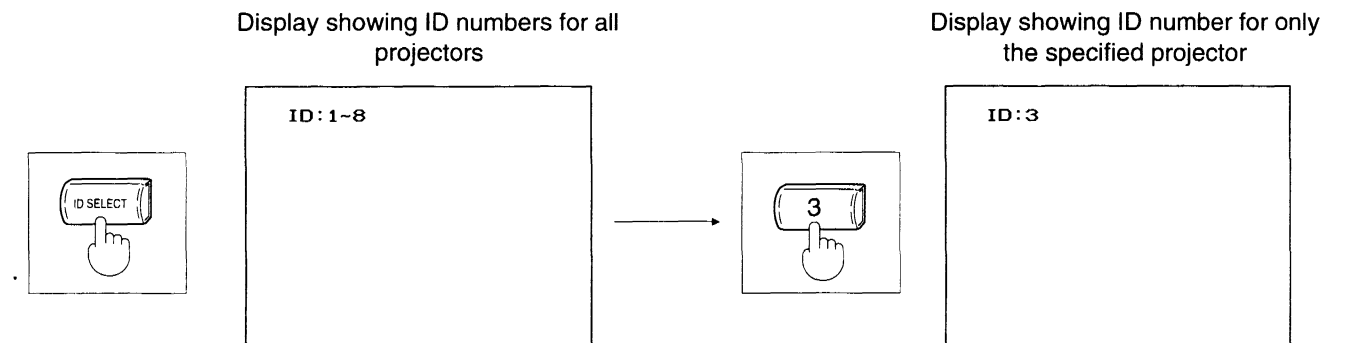

NOTE:

- If the ID number has not been set, “ID:0” will be displayed.
- If no numeric key is pressed to specify an ID number within 10 seconds after the ID SELECT key is pressed, the on-screen display will be cleared and setting will not be possible.
- The on-screen display will be cleared approximately 10 seconds after a numeric key is pressed to specify an ID number.
- After this setting has been made, only the specified projector will operate when a remote control button is pressed.

Setting an ID number when one projector is used

All remote control buttons can be used when the projector is set to either simultaneous or individual operation mode.

System configuration examples

Using the REMOTE IN 1 connector

Turning the projector power on and off and switching the projector input can be carried out externally by connecting an external control circuit such as the one shown in the illustration below to the REMOTE IN 1 terminal of the projector.

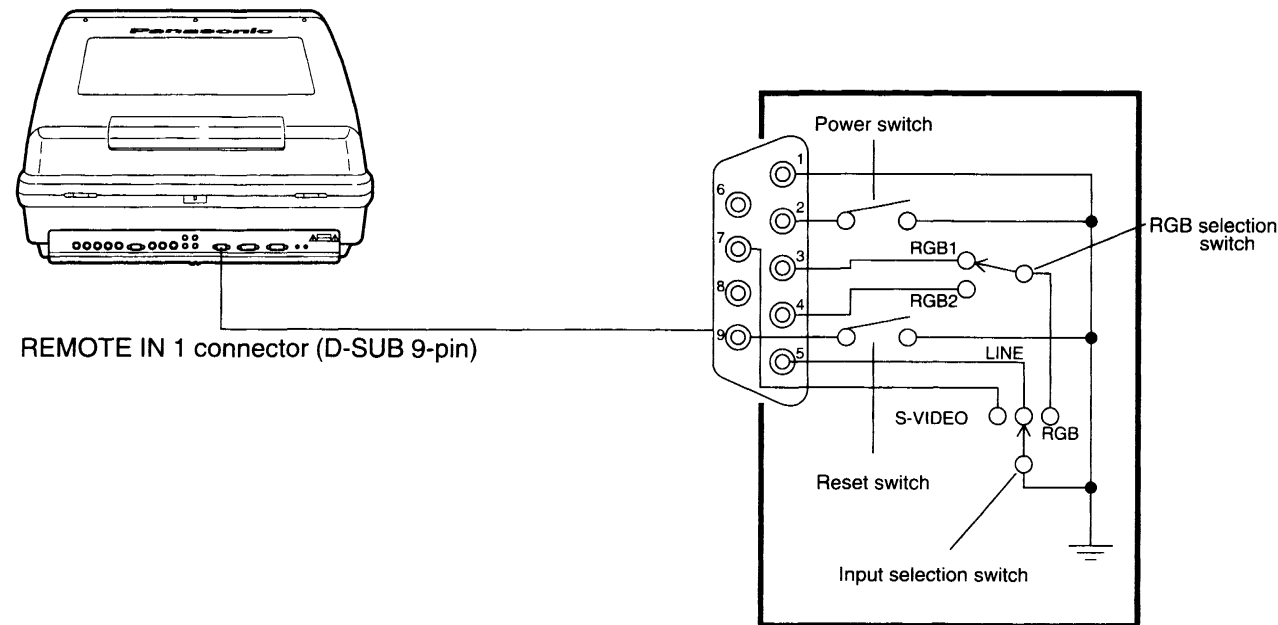

NOTE:

- When an external control circuit has been connected in order to control the projector (when the reset switch shown in the above illustration is on), the operation panel and the remote control unit can no longer be used to turn the power of the projector on and off or to switch the projector input.

Operation using the external control circuit

- ① Turn off the main power switch on the projector.
- ② Set the reset switch of the external control circuit to on.
(External control by means of the REMOTE IN 1 connector will be possible once the reset switch has been turned on.)
- ③ Turn on the main power switch on the projector.
- ④ Turn the power for the projector on and off using the power switch on the external control circuit.
- ⑤ Use the RGB selection switch and input selection switch of the external control circuit to change the projector input.

Notes on setting up a system

- Turn off the power supply for each input device before connection.
- Read the instruction manual for each input device before connection.
- If the cables which are necessary for connecting any of the input devices to the system are not provided with the devices, contact your dealer.
- The projector is not provided with its own speakers, so you will need to connect an external amplifier and speakers in order to obtain audible sound output.
- The following types and ranges of signals can be input to the projector.
 - Analog RGB signals
 - Horizontal scanning frequency: 15 ~ 100 kHz (PT-M1085U)
 - 15 ~ 70 kHz (PT-M1083U)
 - Vertical scanning frequency: 38 ~ 150 Hz
 - Composite video and S-VIDEO signals
 - NTSC, M-NTSC, PAL, SECAM
- A separate interface will be required if the input signal levels are not appropriate.
- If there is a lot of jitter in the video signal input from the video source, the picture on the screen may flicker or be unstable. In such cases, it will be necessary to connect a TBC (time base corrector).
- If the synchronizing signal is a composite sync signal, connect the signal source to the "H/H.V" terminal; if it is a separate sync signal, connect to the "H/H.V" and "V" terminals.
- Do not use the "H/H.V" or "V" signals if the input is a SYNC ON G signal.

Example of a system connected to the RGB IN 1 terminals

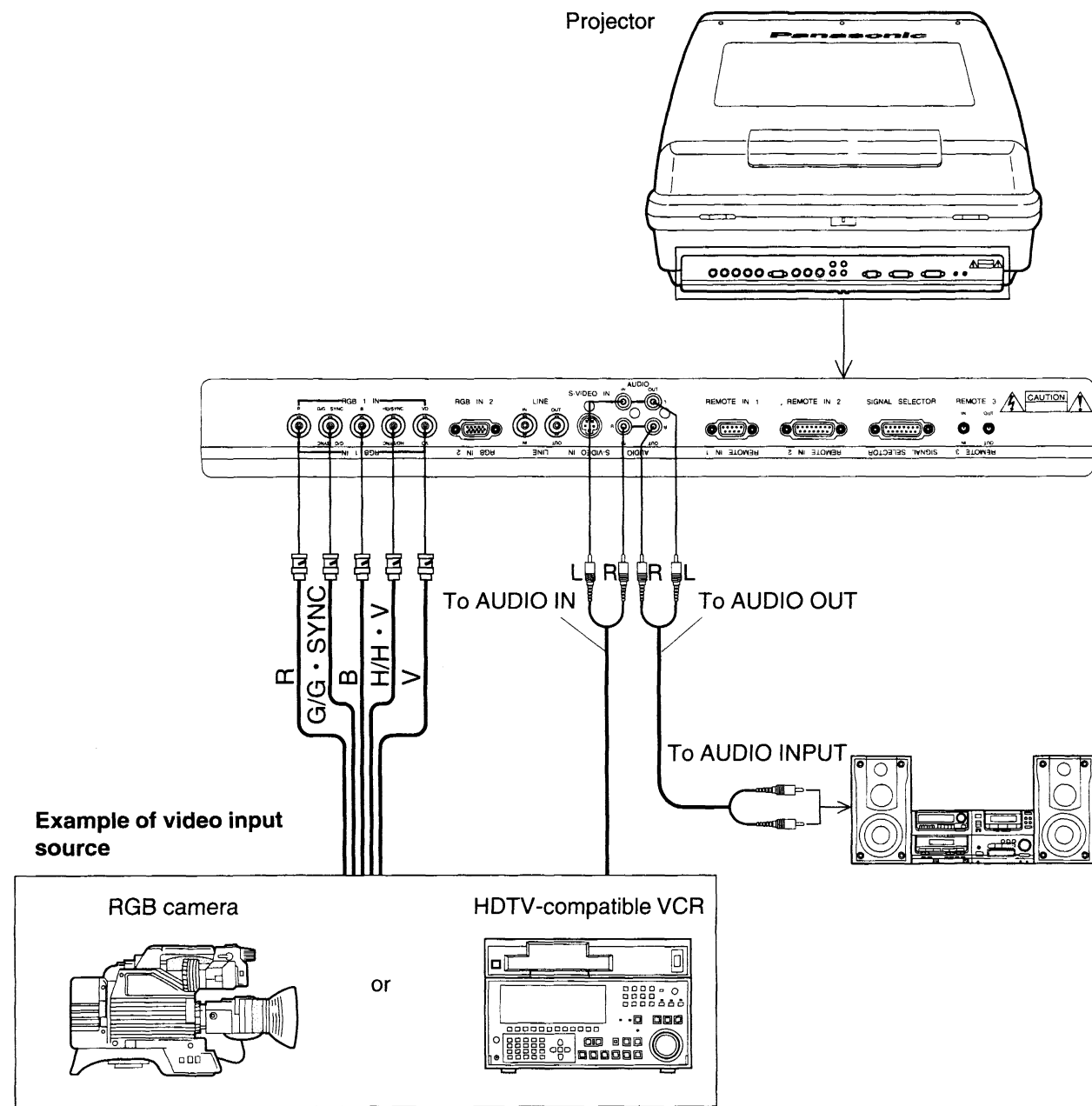

NOTE:

- The projector is not equipped with built-in speakers, so you will need to connect an external amplifier and speakers.
- The audio source for the projector cannot be changed.

Example of a system connected to the RGB IN 2 terminal

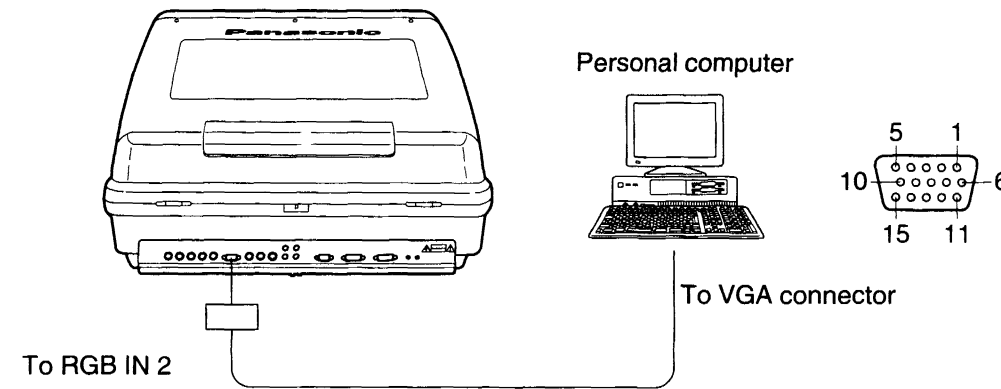

Pin No.	Signal name
1	Red
2	Green
3	Blue
4	GND
5	GND
6	Red GND
7	Green GND
8	Blue GND
9	GND
10	GND
11	GND
12	GND
13	H-Sync
14	V-Sync
15	GND

Example of a system connected to the LINE/S-VIDEO terminals

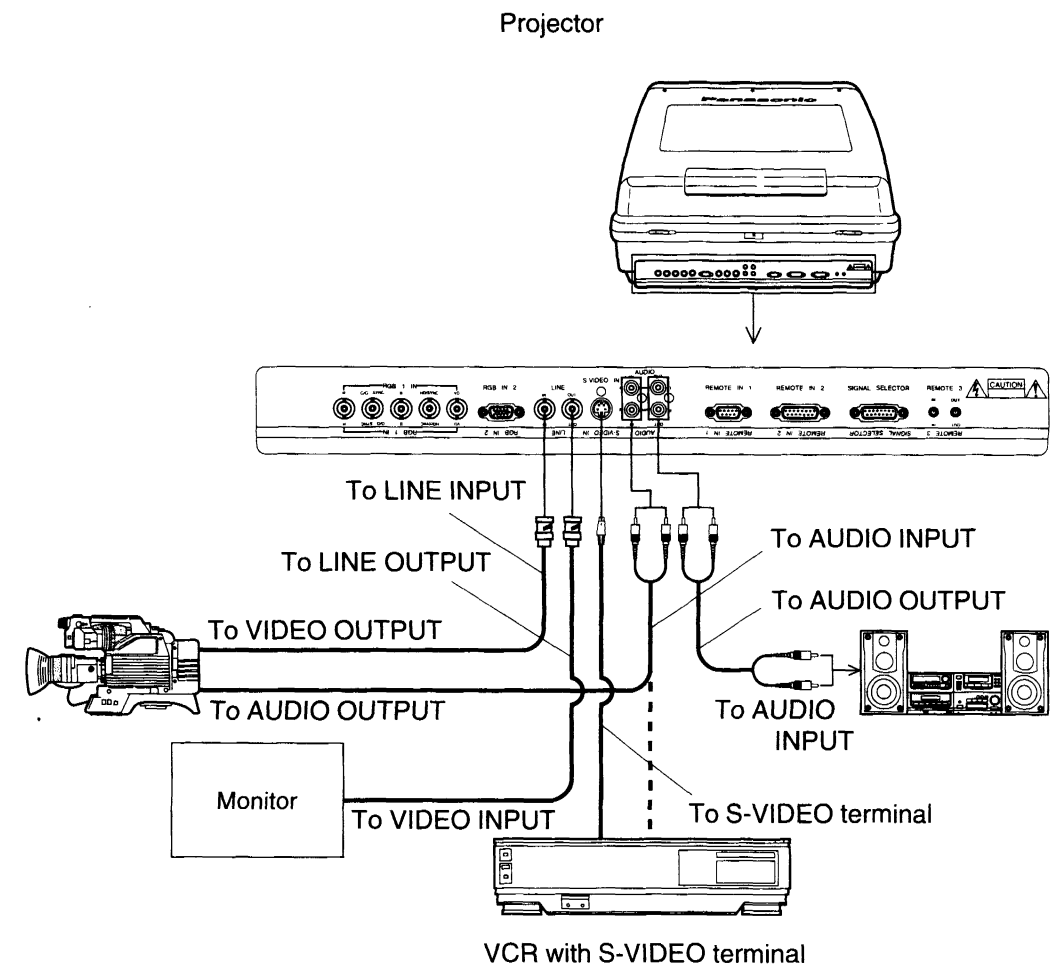

NOTE:

- The projector is not equipped with built-in speakers, so you will need to connect an external amplifier and speakers.
- The audio source for the projector cannot be changed.

Connecting to a S-VIDEO signal source

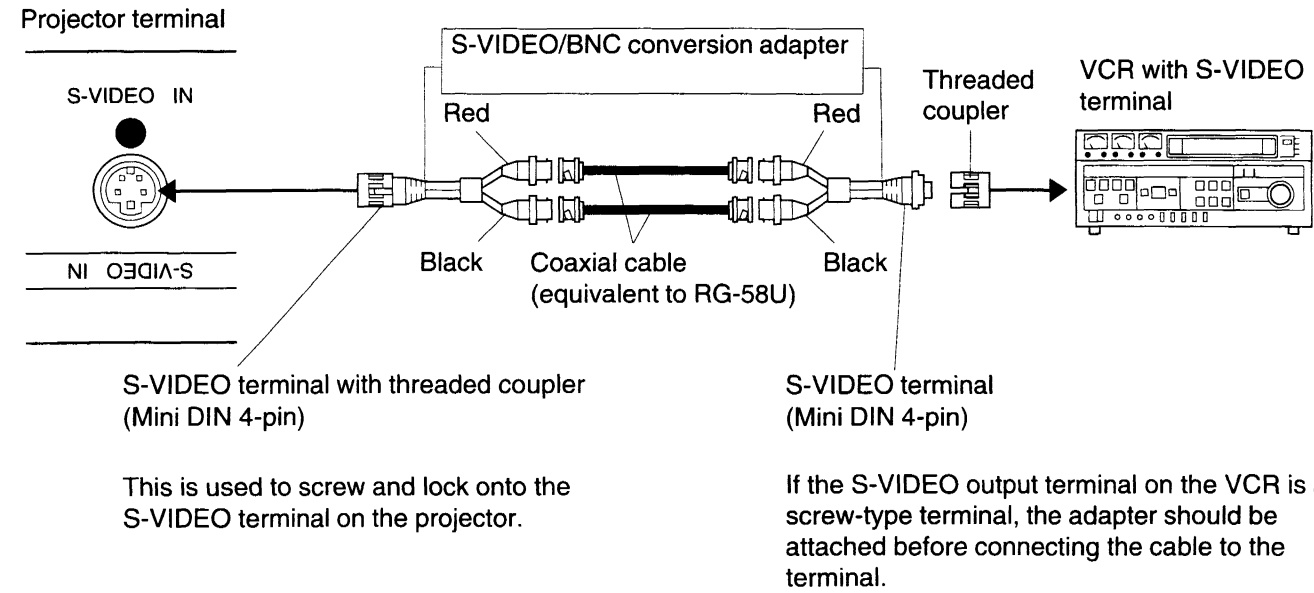

This is used to screw and lock onto the S-VIDEO terminal on the projector.

If the S-VIDEO output terminal on the VCR is a screw-type terminal, the adapter should be attached before connecting the cable to the terminal.

These conversion adapters make it possible to increase the distance between the S-VIDEO terminal connections using BNC cables.

Points to note:

1. The cables used should be of the same length, and this length should not exceed 328 feet (100 m). Exceeding this length will have an adverse effect on Y/C signal transmission.
2. The connectors are color keyed; the Y signal connector is red and the C signal connector is black.

Care should be exercised to ensure proper "red" to "red" and "black" to "black" cable connection.

3. To prevent connector damage or loss, do not place too much strain on the S-VIDEO connectors once they are connected.

Pin No.	Description	Pin No.	Description
1	GND	3	Y signal input
2	GND	4	C signal input

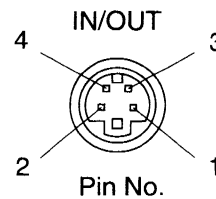

Connecting an advanced digital scanning converter (sold separately)

A separate advanced digital scanning converter (ET-100DS) can be used to convert the signals from the video source to RGB signals (with a horizontal scanning frequency of 31.5 kHz).

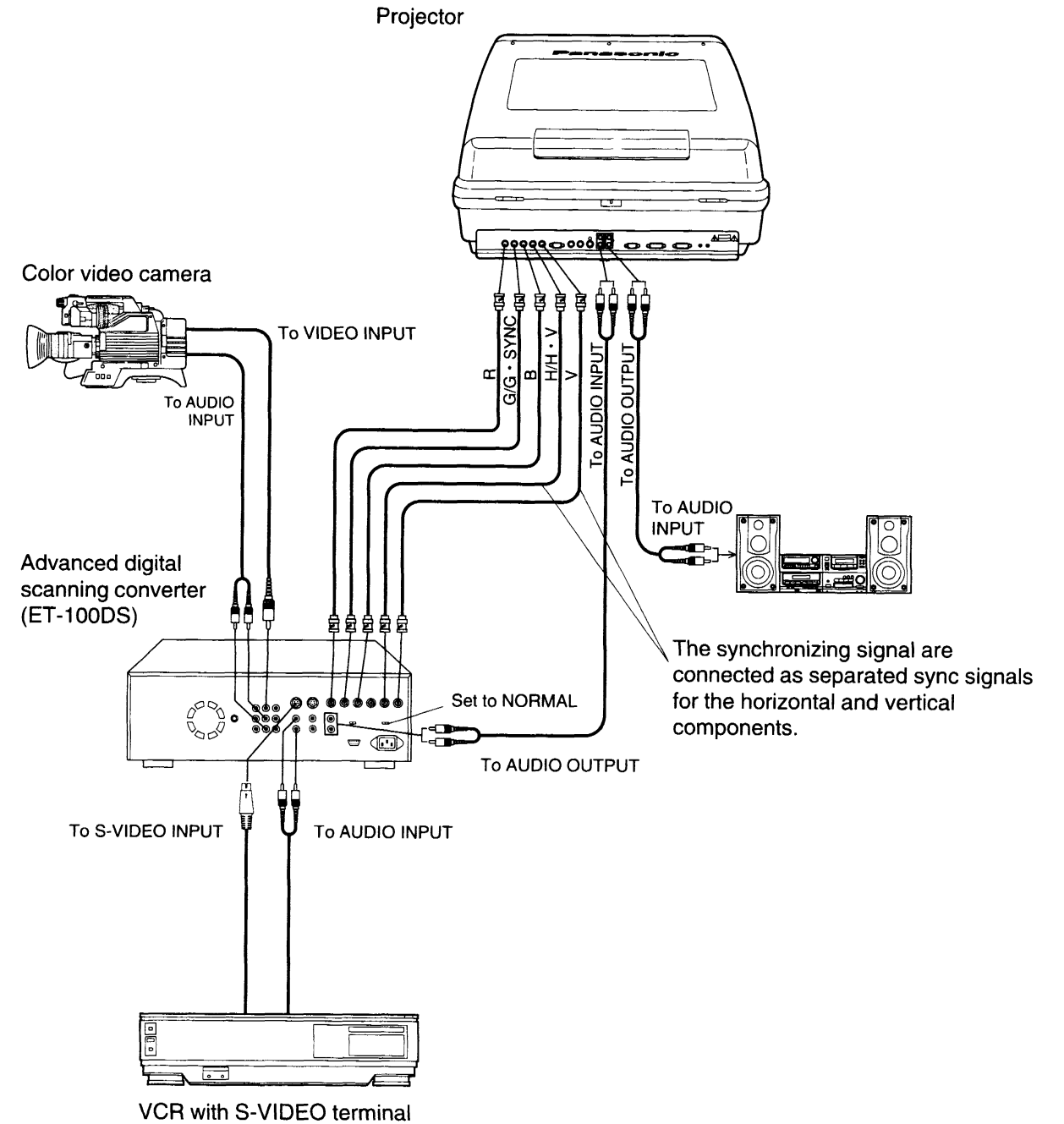

The synchronizing signal are connected as separated sync signals for the horizontal and vertical components.

Input signal recording function

The projector can identify and record the input signals based on the signal format and frequency and the type of synchronizing signal. The relationship between the type of signal and the memory is shown in the table below. (A maximum of three types of adjustments can be stored in a single memory address.)

Input signal		Aspect mode No. 1	Aspect mode No. 2	Aspect mode No. 3
RGB	Address No. A1	<ul style="list-style-type: none"> ● Aspect ratio ● Color temperature ● Image center position ● Raster linearity adjustment ● Blanking adjustment ● White balance adjustment ● Convergence adjustment ● Clamp position setting 	Same as at left	Same as at left
	A2 B8	Same as above	Same as above	Same as above
LINE	NTSC/M-NTSC	Same as above	Same as above	Same as above
	PAL/SECAM	Same as above	Same as above	Same as above
S-VIDEO	NTSC/M-NTSC	Same as above	Same as above	Same as above
	PAL/SECAM	Same as above	Same as above	Same as above

NOTE:

Memory recording should only be carried out by a qualified technician. Consult the technician during setting-up and adjustment.

Optimum viewing position

If a normal flat screen is being used, there are no particular limits on the viewing angle, so the picture can be viewed from almost anywhere. However, the optimum positions for viewing are shown in the illustration below.

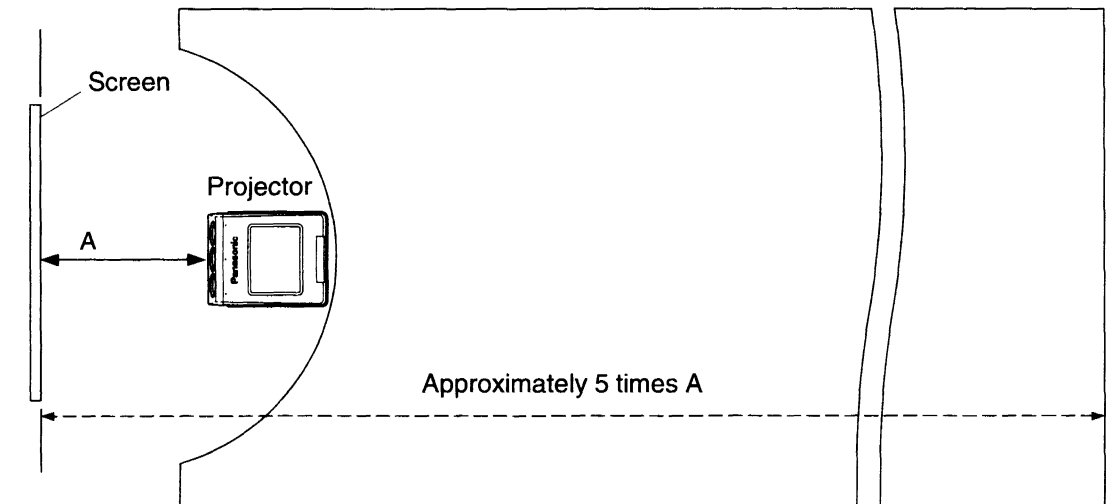

Setting-up examples

Always consult a qualified technician for matters regarding setting-up and adjustment.

Example 1 Setting up on the floor

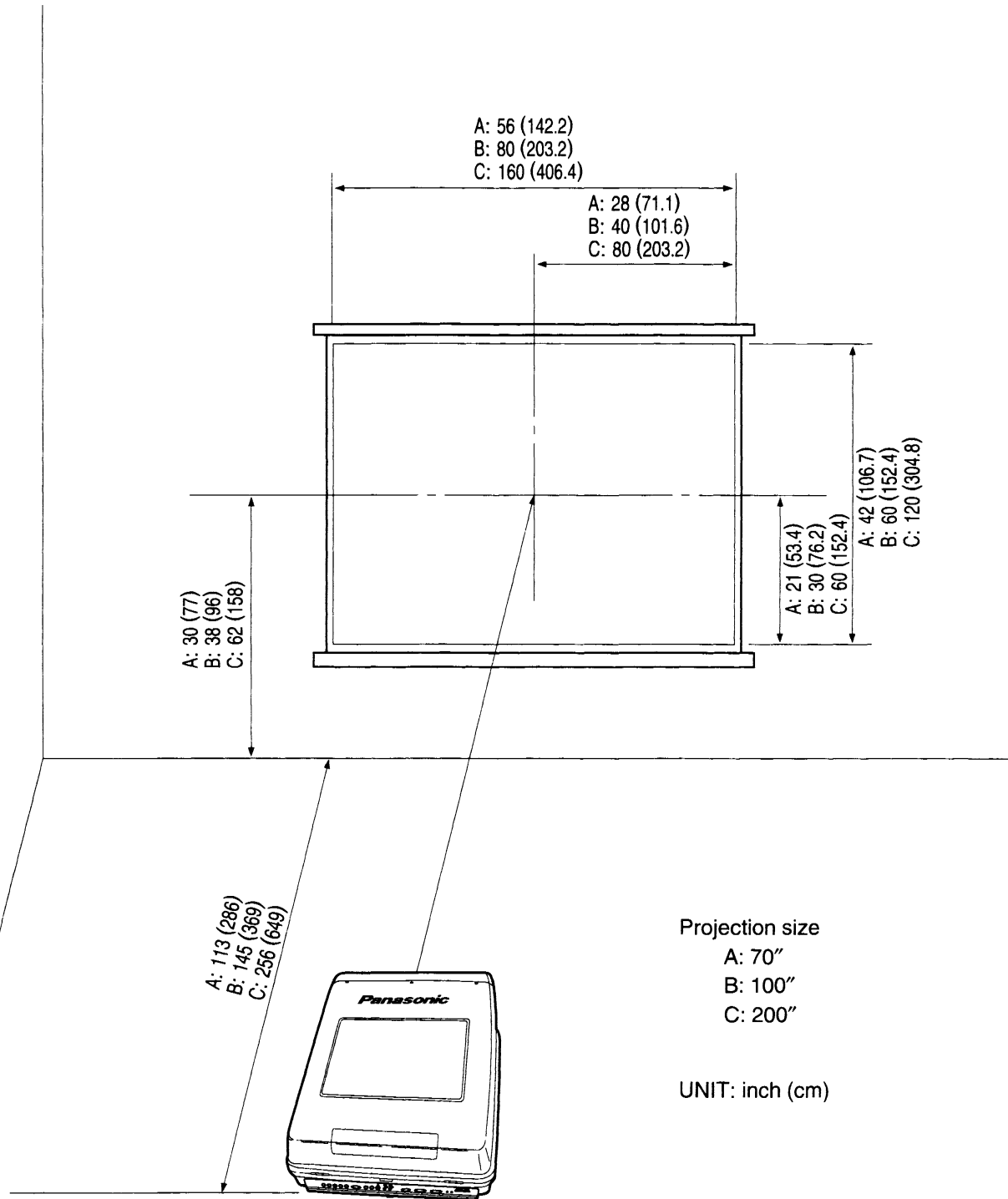

Example 2 Suspending from the ceiling

The special attachment (ET-PK180) which is sold separately is necessary if suspending the projector from the ceiling.

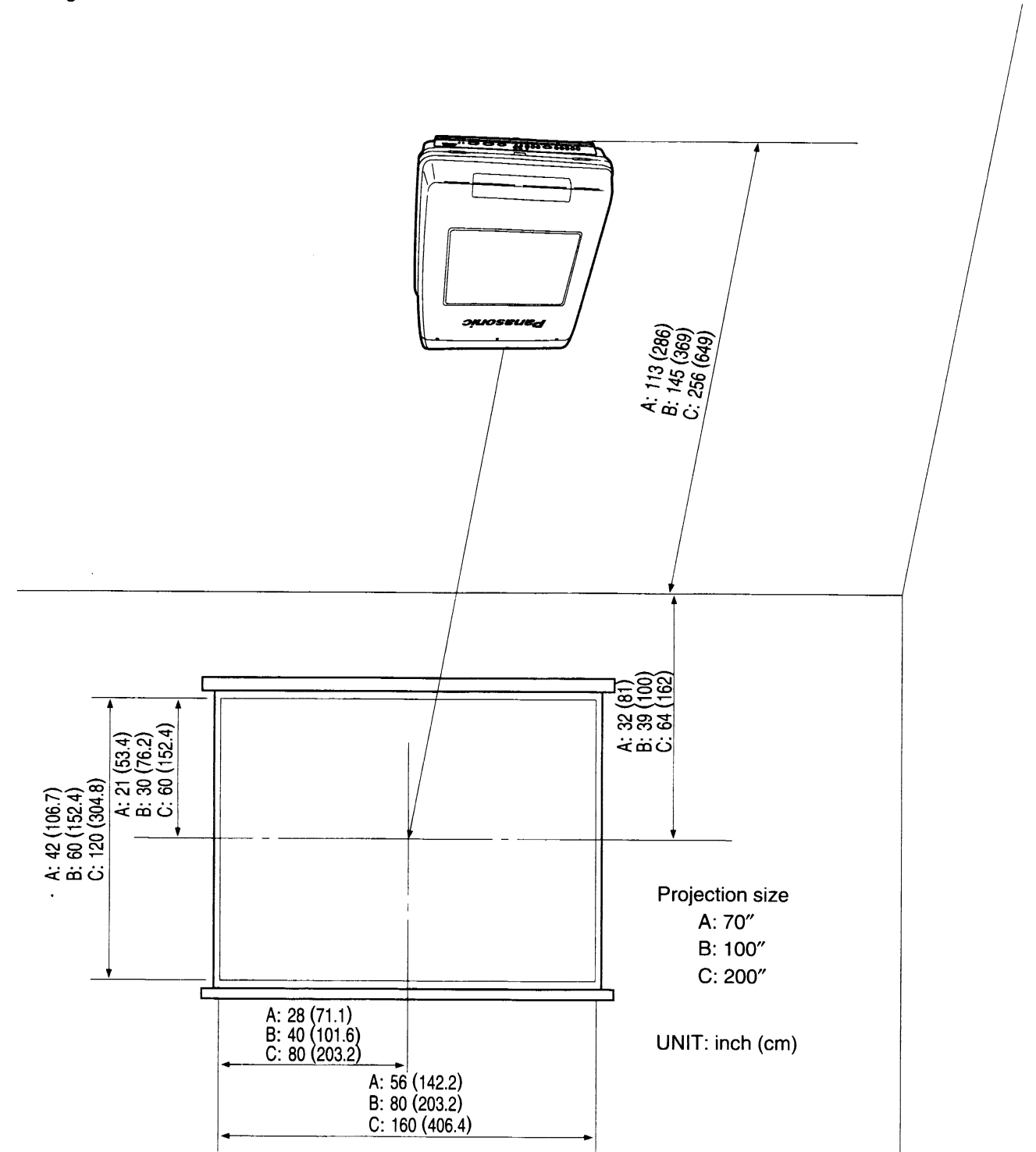

Example 3 Setting up behind the screen

In this method, the picture image is projected onto the rear of the screen and passes through the screen. A translucent screen should be used, and the projector should be tilted at an angle of 12.0° so that the picture image is projected horizontally onto the screen.

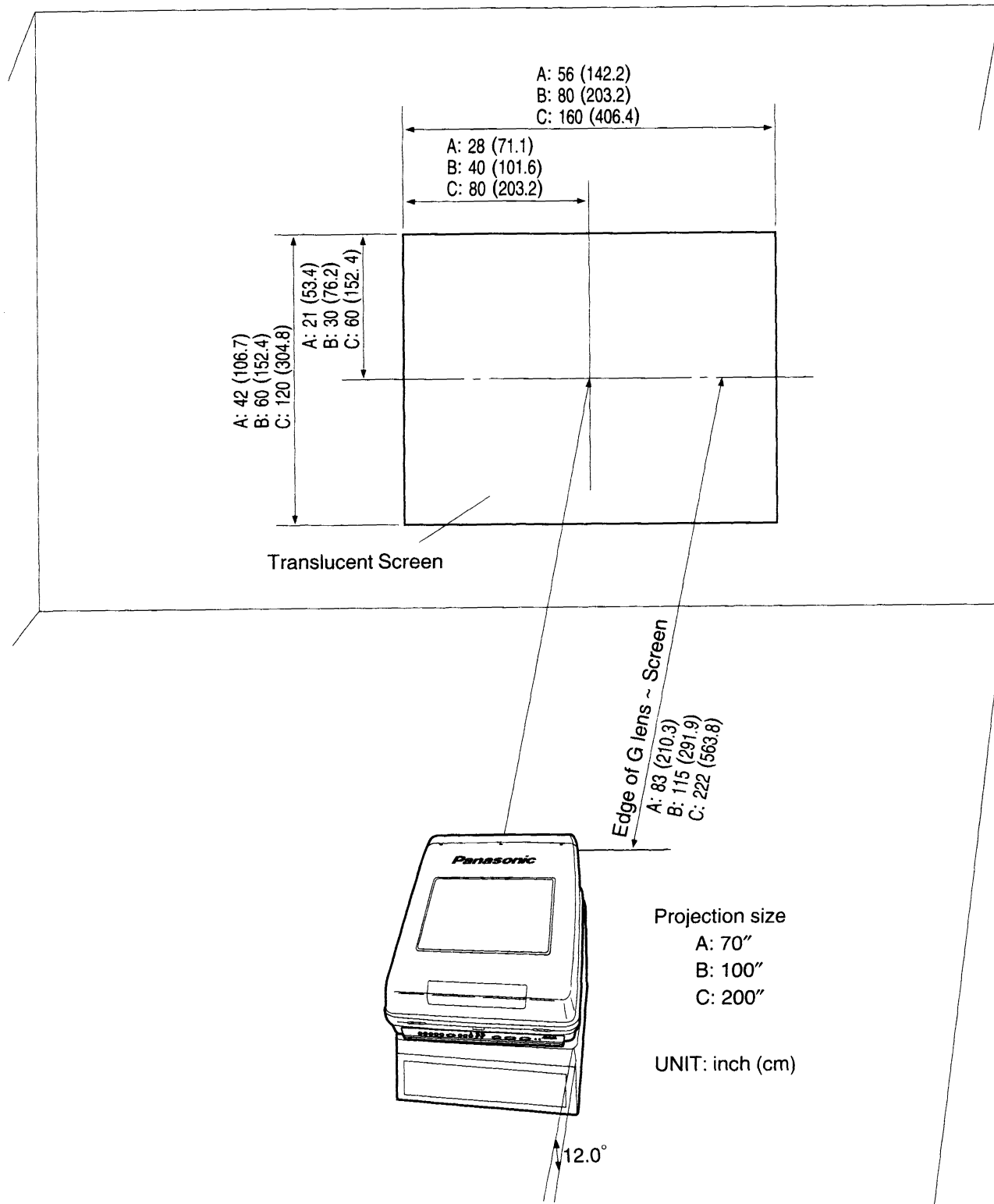

Requirements for the screen

1. Selecting the screen

The projector can project onto either a flat or curved screen. However, the brightness and viewable range will vary depending on the type of screen used.

When selecting a screen, check the characteristics of the screen to ensure that it is suitable for the intended place of use.

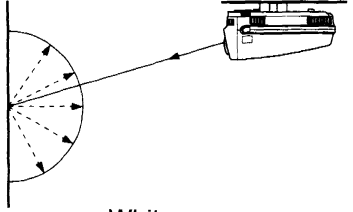
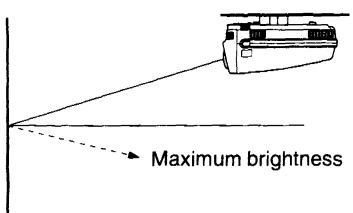
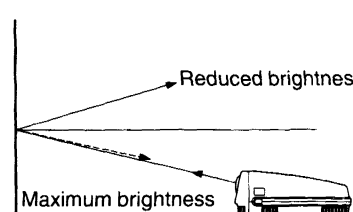
	Screen type	Screen characteristics
Flat screens	White screen	This type of screen can be seen from anywhere, so there are no limits on the viewing position. However, the surrounding walls should be darkened as in a movie theater, otherwise a clear picture cannot be obtained.  White screen
	Silver screen	This type of screen gives a picture which is 2-4 times brighter than a white screen. A variety of types are available from different manufacturers, and each type has different brightness characteristics. Some also have restrictions on the possible range of viewing positions. <ul style="list-style-type: none"> ※ Care should be taken with screens that have a high gain, as these types of screen can cause color distortion at the left and right edges. ※ This type of screen is recommended when the projector is suspended from the ceiling.  Silver screen
	Beaded screen	This type of screen is similar to the silver screen, except that no color distortion occurs at the left and right edges. Moreover, most of the light is reflected at the same angle as the angle of incidence. <ul style="list-style-type: none"> ※ This type of screen is recommended when the projector is placed on the floor.  Beaded screen
Translucent screens	Flexible translucent screen	This is a PVC (Polyvinyl Chloride) screen which comes in two types: 6.6 feet (2 m) rolls and 9.8 feet (3 m) rolls. It has the same characteristics as silver screens, but sometimes it has hot spots.
	Rigid-type translucent screen	This type of screen is made of acrylic and comes in sizes such as 96 inch (2440 mm) (W) × 72 inch (1830 mm) (H) and 0.1 inch (3 mm) thickness. This type of screen is extremely durable and has excellent optical characteristics. It performs in the same way as silver screens.

2. Screen sizes

The screen used should normally have an aspect ratio of 4:3, but if the screen aspect of the picture being projected is 16:9, as is the case for high-definition television (HDTV) broadcasts, the screen size will become smaller as indicated below as a result of adjustments made during setup.

● 70-inch screen

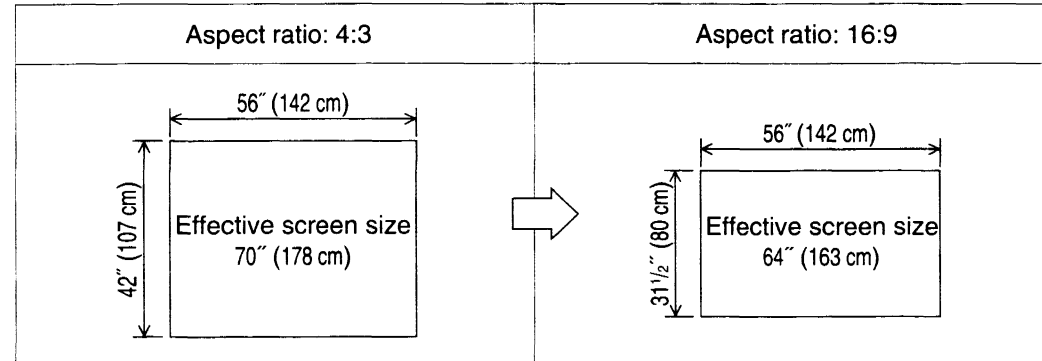

● 100-inch screen

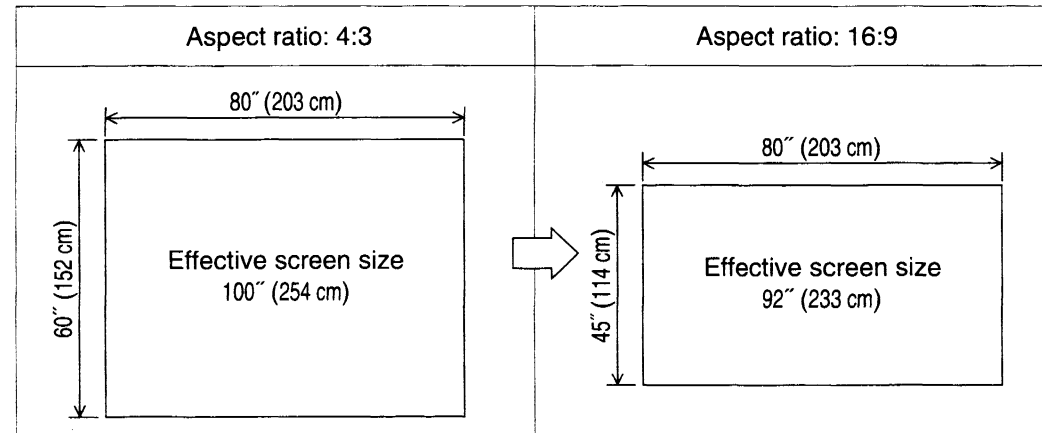

● 200-inch screen

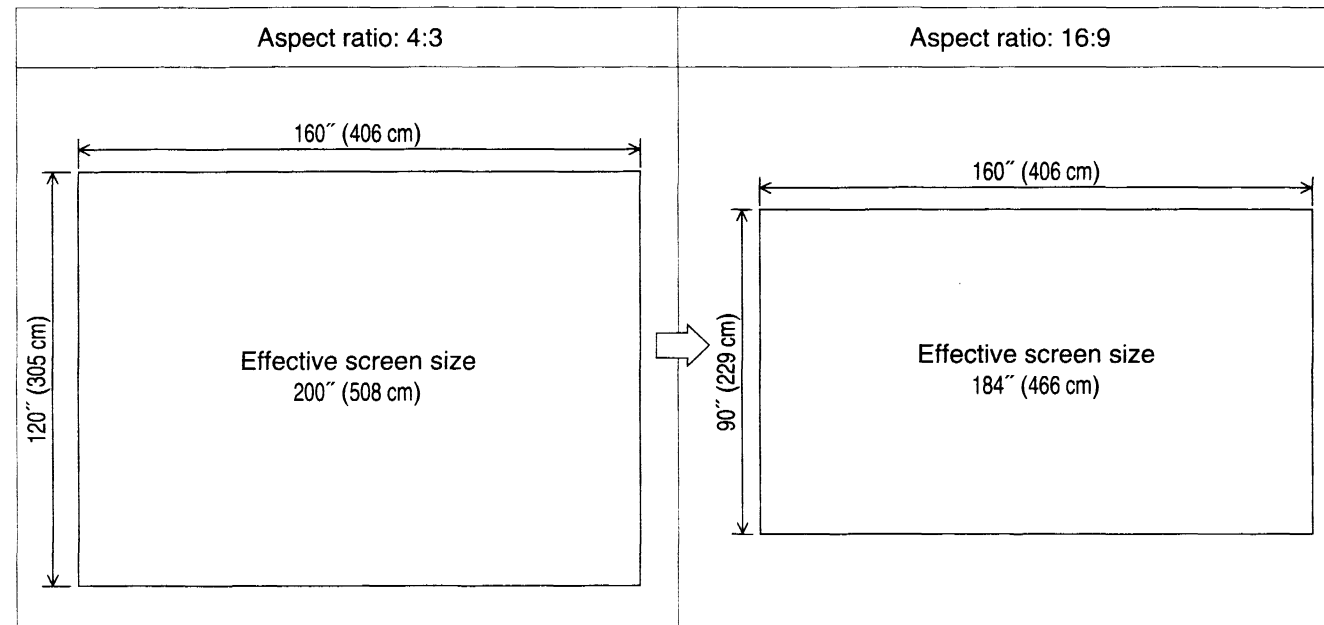

Troubleshooting

Check the following before calling for service.

Problem	Possible cause	Problem	Possible cause
Power does not turn on.	<ul style="list-style-type: none"> ● The main power supply is not turned on. ● The power cord is not connected. ● The main power switch on the projector is turned off. ● The projector is being controlled by an external control device which is connected to the REMOTE IN 1 connector. (Refer to page 27.) ● An incorrect ID number is being used. (Refer to page 26.) 	Color is misaligned for a certain input signal.	<ul style="list-style-type: none"> ● The signal being input is a new type of signal which was not recorded during setting-up and adjustment.
		Adjustment of the brightness and black level of the picture is not possible.	<ul style="list-style-type: none"> ● The projector is being controlled by an external control device which is connected to the REMOTE IN 1 connector. (Refer to page 27.)
		The on-screen display does not appear.	<ul style="list-style-type: none"> ● The on-screen display has been turned off. (Refer to page 24.)
No picture appears.	<ul style="list-style-type: none"> ● The picture transmission cable is not connected. ● A device which has been connected to the projector is not operating correctly. 	<p>The remote control unit operations do not correspond to the buttons being pressed.</p> <ul style="list-style-type: none"> ● The button name display selection switch has been set incorrectly. (Refer to page 10.) ● The function selection switch inside the battery compartment has been turned on. (Refer to page 10.) 	

Specifications

Power supply:	AC 120 V, 60 Hz
Power consumption:	
PT-M1085U:	470 W (9 W during remote control standby)
PT-M1083U:	430 W (9 W during remote control standby)
MAX Amps:	
PT-M1085U:	5.9 A
PT-M1083U:	5.4 A
Picture tube:	7-inch liquid cooled high-brightness electrostatic focusing tube × 3
Lenses:	F1.03 hybrid lens × 3 (with red and green color lenses)
Luminous output:	850 lumens at peak output
Resolution:	1,600 × 1,280 dots (PT-M1085U) 1,500 × 1,200 dots (PT-M1083U)
Video band:	90 MHz (PT-M1085U) 75 MHz (PT-M1083U)
Horizontal scanning frequency:	15 ~ 100 kHz (PT-M1085U) 15 ~ 70 kHz (PT-M1083U)
Vertical scanning frequency:	38 ~ 150 Hz
Recorded data capacity:	RGB signals: 16 addresses × 3 modes LINE signals: 2 addresses × 3 modes S-VIDEO signals: 2 addresses × 3 modes
Projection size at shipment:	120 inches (ceiling-mounted type)
Power cord length:	8.2 feet (2.5 m)
Weight:	136.4 pounds (62 kg)
Dimensions:	Width: 25 ³ / ₃₂ inches (637 mm) Height: 14 ¹³ / ₁₆ inches (376 mm) Depth: 32 ⁵ / ₃₂ inches (817 mm)
Ambient conditions:	Temperature: 23°F ~ 104°F (-5 ~ 40°C) Humidity: 20 ~ 80%
Connection terminals:	
Analog RGB IN 1 terminals (BNC × 5):	R, G, B 0.7 V _{p-p} 75 Ω G.SYNC 1.0 V _{p-p} 75 Ω H/H.V 0.3 - 5.0 V High impedance V 0.3 - 5.0 V High impedance
Analog RGB IN 2 terminal (D-SUB HD15-pin):	VGA-compliant
LINE IN/OUT terminals (BNC × 2):	1.0 V _{p-p} , 75 Ω or high impedance
S-VIDEO terminal (Mini DIN 4-pin (lock type)):	Y signal 1.0 V _{p-p} , positive polarity (with negative sync signal) 75 Ω C signal 0.286 V _{p-p}
AUDIO IN/OUT terminals (Stereo RCA jack × 4):	0.5 V _{rms} 33 kΩ or higher
REMOTE IN 1 connector (D-SUB 9-pin):	For external control
REMOTE IN 2 connector (D-SUB 15-pin):	For adjustment and maintenance
REMOTE 3 IN/OUT terminals (M3 plug):	For connecting the remote control and for serial operation
SIGNAL SELECTOR connector (D-SUB 15-pin):	For connecting a signal selector (for future use)
Internal test signals:	7 signals (crosshatch, crosshair, dot, H character, window, full white, pluge)
Convergence:	Digital control, separate 21-zone adjustment

<Remote control unit>	
No. of functions:	62 functions (43 key-in functions) including a lighting function and control pattern switch
Power supply:	DC 3 V (four AA-size batteries)
Operation range:	Approx. 39.7 feet (12 m) without cable connected (from directly in front of receptor) Approx. 49.2 feet (15 m) with cable connected
Weight:	Approx. 0.77 pounds (350 g) (with batteries)
Dimensions:	Width: 5 ⁸ / ₁₆ inches (140 mm) Height: 1 ¹³ / ₃₂ inches (36 mm) Length: 7 ² / ₁₆ inches (181 mm)
Accessories:	
Remote control unit:	1
AA-size batteries:	4
Remote control cable:	1 (Approx. 49.2 feet [15 m])
Remote control strap:	1
Power cord:	1 (8.2 feet [2.5 m])
Lens caps:	3
Lens spacer:	70-inch/Front 3 200-inch/Front 3 70-inch/Rear 3 100-inch/Rear 3 200-inch/Rear 3
S-VIDEO/BNC conversion adapters:	2
Option:	Mounting plate kit ET-PK180

Panasonic®

Professional/Industrial Video

Panasonic Broadcast & Television Systems Company

Division of Matsushita Electric Corporation of America

Executive Office:

One Panasonic Way (3F-5) Secaucus, New Jersey 07094

EASTERN ZONE:

43 Hartz Way, Secaucus, NJ 07094 (201) 348-7620

CENTRAL ZONE:

1707 N. Randall Rd., Elgin, IL 60123 (708) 468-5200

SOUTHERN ZONE:

Dallas Region: 4500 Amon Carter Blvd., Fort Worth, TX 76155 (817) 685-1117

Atlanta Region: 1225 North Brook Parkway, Suite 170, Suwanee, GA 30174 (404) 338-6855

WESTERN ZONE:

Los Angeles Region: 6550 Katella Ave., Cypress, CA 90630 (714) 373-7275

Government Marketing Department: 52 West Gude Drive, Rockville, MD 20850 (301) 738-3840

Matsushita Electric Corporation of America

Corporate Sales Group, Hawaii Region

99-859 Iwaiwa ST., Alea, HI 96701-3267 (808) 488-7779

Matsushita Electric of Canada Limited

5770 Ambler Drive, Mississauga, Ontario L4W 2T3 (905) 624-5010

Panasonic Sales Company

Division of Matsushita Electric of Puerto Rico, Inc.

San Gabriel Industrial Park, 65th Infantry Ave., K.M. 9.5, Carolina, PR 00630 (809) 750-4300