

BARCO  **GRAPHICS**
1208

90 00890 - 90 00891

90 00898 - 90 00899

OWNER'S MANUAL

BARCO

BARCO PROJECTION SYSTEMS

BARCO GRAPHICS
1208

90 00890 - 90 00891
90 00898 - 90 00899

OWNER'S MANUAL

Date:
150494



Revision :
01



Art. No.
59 75565

Due to constant research, the information in this manual is subject to change without notice.

**Produced by BARCO NV, April 1993
All rights reserved.**

Trademarks are the rights of their respective owners.

Printed in Belgium

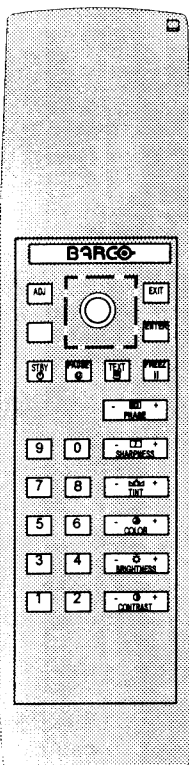

New RCU for BARCO projectors.

* The four arrow keys are replaced by a joy stick.
This joy stick can be pushed to the left, to the right, forwards and backwards.

Replace in the text of this manual :

- right arrow key by *push joy stick to the right.*
- left arrow key by *push joy stick to the left.*
- up arrow key by *push joy stick forwards.*
- down arrow key by *push joy stick backwards.*

* The RCU operating indication is moved from the lower part (bottom) of the RCU to the top of the RCU.

TABLE OF CONTENTS

WARNINGS	5
SAFETY INSTRUCTIONS	5
On safety	8
On installation	9
On servicing	10
On cleaning	10
On repacking	11
On illumination	11
LOCATION AND FUNCTION OF CONTROLS	13
Rear panel terminology	14
Front panel terminology	15
RCU control panel terminology	16
POWER (MAINS) CONNECTION	19
Power (mains) cord connection	20
Power check	20
Switching on	21
SOURCE CONNECTIONS	23
Signal input connection to the projector :	24
Connecting a Composite Video source to port 1.	25
Connecting an S-Video source to port 2	26
Connecting a RGB Analog source to port 3.	27
Connecting a RGB analog source to port 4/5.	28
PERIPHERAL EQUIPMENT	29
Connecting a RCVDS 800 to the BARCOGRAPHICS 1200.	29
Connecting an IR Remote Receiver 800 to the BARCOGRAPHICS 1200.	29
CONTROLLING	31
How to use your RCU	32
Projector address	34
How to display a projector address?	35
How to program an address into the RCU?	35
Input selection	35
Picture controls	37
Controlling chained projectors.	39
START UP OF THE ADJUSTMENT MODE	41
Adjustment mode.	43
GUIDED ADJUSTMENT MODE	47
Start up of the guided adjustment mode.	48
Overview flowchart 'Guided Adjustment' procedure.	49
Selecting Setup Pattern	51

Internal Cross Hatch Pattern	52
Picture tuning toggle switches	54
Sync Fast/Slow toggle	54
Enhanced blue ON/OFF	54
Raster Centering on Green CRT Faceplate	55
Shifting Red and Blue on Green	57
Focusing	57
Midpoint focusing	58
Top image focusing	58
Bottom image focusing	59
Left image focusing	59
Right image focusing	60
Left-Right (East-West) Adjustments	60
Vertical Centerline Bow Adjustment	61
Vertical Centerline Skew Adjustment	62
Side Keystone Adjustment	63
Side Bow Adjustment	64
Horizontal Size Adjustment	65
Top-Bottom (North-South) Adjustments	66
Horizontal Centerline Skew Adjustment	67
Horizontal Centerline Bow Adjustment	68
Top Keystone Adjustment	69
Top Bow Adjustment	70
Bottom Keystone Adjustment	71
Bottom Bow Adjustment	72
Size-linearity Adjustment	73
Vertical Linearity Adjustment	74
Vertical Size Adjustment	75
Horizontal Phase Adjustment	76
Convergence Adjustment	77
Blanking Adjustment	79
Top blanking adjustment	80
Bottom blanking adjustment	81
Left blanking adjustment	82
Right blanking adjustment	83
White balance	84
Black balance	85
RANDOM ACCESS ADJUSTMENT MODE	87
Starting up the random access adjustment mode	88
Overview flowchart 'Random Access Adjustment' mode	89
Selecting Setup Pattern	91
Internal Cross Hatch Pattern	92
Random access adjustment mode selection menu	93
Sync Fast/Slow Adjustment	94
Enhanced Blue On/Off Adjustment	94
Focusing	95
Focusing color select	95
Midpoint focusing	96
Top image focusing	97

TABLE OF CONTENTS

Bottom image focusing	98
Left image focusing	99
Right image focusing	100
Color Select	101
Color balance	102
White balance	102
Black balance	103
Geometry Adjustments	104
Horizontal Phase Adjustment	105
Raster Shift Adjustment	107
Left-Right (east-west) Adjustments	109
Vertical Centerline Bow Adjustment	110
Vertical Centerline Skew Adjustment	111
Side Bow Adjustment	112
Side Keystone Adjustment	113
Top-Bottom (north-south) Adjustments	114
Horizontal Centerline Bow Adjustment	115
Horizontal Centerline Skew Adjustment	116
Top Keystone Adjustment	117
Top Bow Adjustment	118
Bottom Keystone Adjustment	119
Bottom Bow Adjustment	120
Horizontal Size Adjustment	121
Vertical Size Adjustment	122
Vertical Linearity Adjustment	123
Blanking Adjustments	124
Top Blanking Adjustment	125
Bottom Blanking Adjustment	126
Left Blanking Adjustment	127
Right Blanking Adjustment	128
Convergence Adjustment	129
SERVICE MODE	131
Starting up the service mode	132
Overview flowchart 'Service' mode	133
Start up screen	135
Copy a block	136
Deletion of blocks	137
Deleting block by block	137
Deletion of all blocks	138
Change password	139
Run time	140
Set to midposition	141
Convergence off	142
CRT run in cycle	142
Dynamic astigmatism (spot shape adjustment)	143
MESSAGES, WARNINGS AND FAILURES	147

OPTIONS	153
IR Receiver 800	154
Hardwired RCU800	154
Control 800 software	155
RCVDS 800	155
IRIS 800	155
Adapter and communication cables	156
Orbiting Kit	156
Soft edge matching kit	156
Contrast modulation kit	157
Flight case	157
Suspension system	157
 APPENDIX A: Orbiting	 159
APPENDIX B: Soft edge matching	164
APPENDIX C : Contrast modulation	174
APPENDIX D : Battery replacement in the RCU	179
APPENDIX E : Adjustment Blocks	180
APPENDIX F : Source numbers 90 - 99	181

WARNINGS

SAFETY INSTRUCTIONS

- on safety**
- on installation**
- on servicing**
- on cleaning**
- on repacking**
- on illumination**

Notice on Safety

Projectors are built in accordance with the requirements of the international safety standards IEC 950 and UL 1950, which are the safety standards of information technology equipment including electrical business equipment.

These safety standards impose important requirements on the use of safety critical components, materials and isolation, in order to protect the user or operator against risk of electric shock and energy hazard, and having access to live parts. Safety standards also impose limits to the internal and external temperature rises, radiation levels, mechanical stability and strength, enclosure construction and protection against the risk of fire.

Simulated single fault condition testing ensures the safety of the equipment to the user even when the equipment's normal operation fails.

INSTALLATION INSTRUCTIONS

Before operating your projector please read this manual thoroughly, and retain it for future reference.

Installation and preliminary adjustments should be performed by qualified BARCO personnel or authorized BARCO service dealers.

OWNER'S RECORD

The part number and serial number are located at the rear of the projector. Record these numbers in the spaces provided below. Refer to them whenever you call upon your BARCO dealer regarding this product.

PART NUMBER:**SER. NUMBER:****DEALER:**

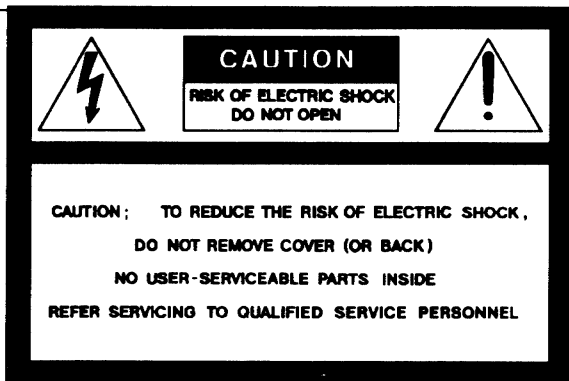

The lightning flash with an arrowhead within a triangle is intended to tell the user that parts inside this product may cause a risk of electrical shock to persons.



The exclamation point within a triangle is intended to tell the user that important operating and/or servicing instructions are included in the technical documentation for this equipment.

WARNING
TO PREVENT FIRE OR ELECTRICAL SHOCK HAZARD, DO NOT EXPOSE THIS PROJECTOR TO RAIN OR MOISTURE

FEDERAL COMMUNICATION COMMISSION (FCC STATEMENT)

This equipment generates, uses, and can radiate radio frequency energy and if not installed and used in accordance with the instruction manual, may cause interference to radio communications. It has been tested and found to comply with the limits for Class A computing device pursuant to Part 15 of FCC Rules, which are designed to provide reasonable protection against such interference when operated in a commercial environment. Operation of this equipment in a residential area is likely to cause interference in which case the user at his own expense will be required to take whatever measures be required to correct the interference.

Note : The use of shielded cables is required to comply within the limits of Part 15 of FCC rules.

- * All the safety and operating instructions should be read before using this unit.
- * The safety and operating instructions manual should be retained for future reference.
- * All warnings on the projector and in the documentation manuals should be adhered to.
- * All instructions for operating and use of this equipment must be followed precisely.

On safety

1. This product should be operated from an AC power source

Operating AC power voltage of the projector:

BARCOGRAPHICS 1208

Art.No. 90 00890 - 90 00891 (230V AC)

Art.No. 90 00898 - 90 00899 (120V AC)

The type of power source is indicated by the art. no. on the identification plate on the rear of the projector.

If you are not sure of the type of AC power available, consult your dealer or local power company.

2. This product is equipped with a 3-wire grounding plug, a plug having a third (grounding) pin. This plug will only fit into a grounding-type power outlet. This is a safety feature. If you are unable to insert the plug into the outlet, contact your electrician to replace your obsolete outlet. Do not defeat the purpose of the grounding-type plug.

WARNING FOR THE CUSTOMERS: THIS APPARATUS MUST BE GROUNDED (EARTHED) via the supplied 3 conductor AC power cable.
(If the supplied power cable is not the correct one, consult your dealer.)

A. Mains lead (AC Power cord) with CEE 7 plug:

The colors of the mains lead are colored in accordance with the following code:

Green-and-yellow:	Earth (safety earth)
Blue:	Neutral
Brown:	Line (Live)

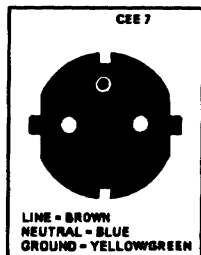

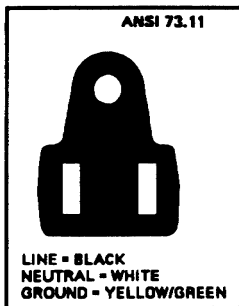
B. Power cord with ANSI 73.11 plug:

The wires of the power cord are colored in accordance with the following code.

Green/yellow: ground
White: neutral
Black: line (live)

3. Do not allow anything to rest on the power cord. Do not locate this product where persons will walk on the cord.

To disconnect the cord, pull it out by the plug. Never pull the cord itself.

4. If an extension cord is used with this product, make sure that the total of the ampere ratings on the products plugged into the extension cord does not exceed the extension cord ampere rating. Also make sure that the total of all products plugged into the wall outlet does not exceed 15 amperes.

5. Never push objects of any kind into this product through cabinet slots as they may touch dangerous voltage points or short out parts that could result in a risk of fire or electrical shock.

Never spill liquid of any kind on the product. Should any liquid or solid object fall into the cabinet, unplug the set and have it checked by qualified service personnel before resuming operations.

6. **Lightning** - For added protection for this video product during a lightning storm, or when it is left unattended and unused for long periods of time, unplug it from the wall outlet. This will prevent damage to the projector due to lightning and AC power-line surges.

On installation

1. Do not place this projector on an unstable cart, stand, or table. The projector may fall, causing serious damage to it.

2. Do not use this projector near water.

3. Slots and openings in the cabinet and the back or bottom are provided for ventilation; to ensure reliable operation of the projector and to protect it from overheating, these openings must not be blocked or covered. The openings should never be blocked by placing the product on a bed, sofa, rug, or other similar surface. This product should never be placed near or over a radiator or heat register. This projector should not be placed in a built-in installation or enclosure unless proper ventilation is provided.

On servicing

Do not attempt to service this projector yourself, as opening or removing covers may expose you to dangerous voltage potentials and risk of electric shock!
Refer all servicing to qualified service personnel.

Unplug this product from the wall outlet and refer servicing to qualified service personnel under the following conditions:

- a. When the power cord or plug is damaged or frayed.
- b. If liquid has been spilled into the projector.
- c. If the product has been exposed to rain or water.
- d. If the product does not operate normally when the operating instructions are followed. Note :
Adjust only those controls that are covered by the operating instructions since improper adjustment of the other controls may result in damage and will often require extensive work by a qualified technician to restore the product to normal operation.
- e. If the product has been dropped or the cabinet has been damaged.
- f. If the product exhibits a distinct change in performance, indicating a need for service.

Replacement parts - When replacement parts are required, be sure the service technician has used original BARCO replacement parts or authorized replacement parts which have the same characteristics as the BARCO original part. Unauthorized substitutions may result in degraded performance and reliability, fire, electric shock or other hazards. Unauthorized substitutions may void warranty.

Safety check - Upon completion of any service or repairs to this projector, ask the service technician to perform safety checks to determine that the projector is in proper operating condition.

On cleaning

Unplug this product from the wall outlet before cleaning. Do not use liquid cleaners or aerosol cleaners. Use a damp cloth for cleaning.

- To keep the cabinet looking brand-new, periodically clean it with a soft cloth. Stubborn

stains may be removed with a cloth lightly dampened with mild detergent solution. Never use strong solvents, such as thinner or benzine, or abrasive cleaners, since these will damage the cabinet.

- To ensure the highest optical performance and resolution, the projection lenses are specially treated with an anti-reflective coating, therefore, avoid touching the lens. To remove dust on the lens, use a soft dry cloth. Do not use a damp cloth, detergent solution, or thinner.

On repacking

Save the original shipping carton and packing material; they will come in handy if you ever have to ship your projector. For maximum protection, repack your set as it was originally packed at the factory.

On illumination

In order to obtain the best quality for the projected image, it is essential that the ambient light which is allowed to fall on the screen be kept to an absolute minimum.

When installing the projector and screen, care must be taken to avoid exposure to ambient light directly on the screen. Avoid adverse illumination on the screen from direct sunlight or florescent lighting fixtures.

The use of controlled ambient lighting, such as incandescent spot light or a dimmer, is recommended for proper room illumination. Where possible, care should also be taken to ensure that the floors and walls of the room in which the projector is to be installed are non-reflecting, dark surfaces. Brighter surfaces will tend to reflect and diffuse the ambient light and hence reduce the contrast of the projected image on the screen.

LOCATION AND FUNCTION OF CONTROLS

REAR PANEL TERMINOLOGY

FRONT PANEL TERMINOLOGY

RCU TERMINOLOGY

Rear panel terminology

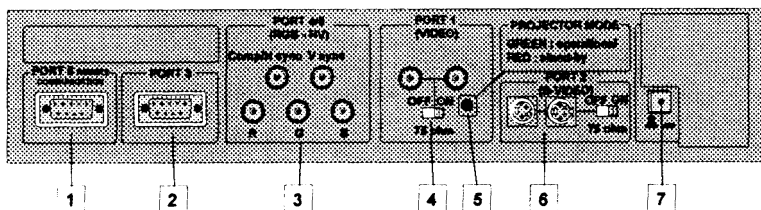

1

Port 6 : Remote Communication :

- * allows communication between the RCVDS switcher and the projector.
- * allows connection of a remote IR receiver unit to the projector.

2

Port 3 : RGB ANALOG input (9-pin female D-connector):

RGB Analog input : allows a character generator, microcomputer, etc. having analog RGB outputs to be connected to the projector. Full automatic sync detection; Hor., Vert., Composite, Sync on green, and polarity detection.
TTL input (option) : allows a character generator, microcomputer, etc. having RGB TTL outputs to be connected.

3

Port 4/5 : RGB-S IN (5x BNC connector): allows a character generator, microcomputer, video camera, etc. having analog RGB output to be connected to the projector.

Line inputs: - RED-GREEN-BLUE signals
 - VERT. sync. signal
 - COMPOSITE sync. or HOR. sync. signal

4

Port 1 : VIDEO IN (Composite video, 2x BNC connector): allows a video tape recorder, video camera, color receiver/monitor, etc. having video line output to be connected to the projector.

When no loop-through connection is desired, put the 75 ohm line termination switch in the ON position.

5

PROJECTOR PILOT LAMP: indicates the status of the projector.

- unlit : mains (power) switch is not pressed.
- lit : mains (power) switch is pressed and the indicated color shows the projector mode:
 - GREEN color: OPERATIONAL mode of the projector
 - RED color: STANDBY mode of the projector.

Important: projector mode ("operational" or "standby") defined during the installation of the projector. (Refer to a qualified technician for change)

- 6** **Port 2: S-VIDEO IN:** Separated Y/C (luma-chroma) signal inputs and outputs for higher quality playback of Super VHS signals (4-pin S-VIDEO IN and S-VIDEO OUT).

When no loop-through connection is desired, put the 75 ohm line termination switch in the ON position.

- 7** **POWER (MAINS) SWITCH:** press the switch to turn the projector ON.

Depending on the hardware set-up of the projector during installation, the projector switches to 'standby' or to 'operational mode' (refer to explanation of pilot lamp [5]).

Front panel terminology

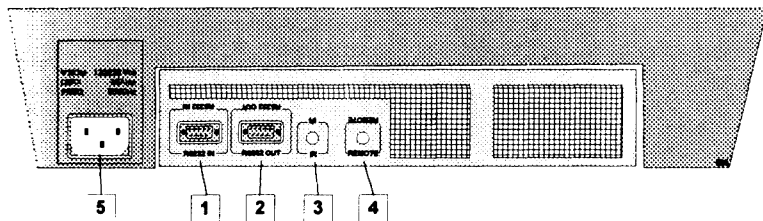

- 1** **RS232 IN:** connection between the BARCOGRAPHICS 1208 and an IBM PC (or compatible) or a MAC (RS422) for remote computer control and data communication.
- 2** **RS232 OUT:** Used to connect to the next projector, RS232IN plug (communication link for PC or MAC to the next projector).
- 3** **IR sensor:** receiver for control signals transmitted from the RCU.
- 4** **REMOTE:** remote input for wired remote control.
- 5** **POWER (MAINS) INPUT:** Connect the supplied ac power (mains) cord here and to wall the outlet.

RCU800 control panel terminology

This remote control includes a battery powered infrared (IR) transmitter that allows the user to control the projector remotely.

This remote control is used for source selection, control, adaptation and set-up. It includes automatic storing of :

- picture controls (Brightness, Sharpness,....)
- picture geometry adjustments
- convergence adjustments

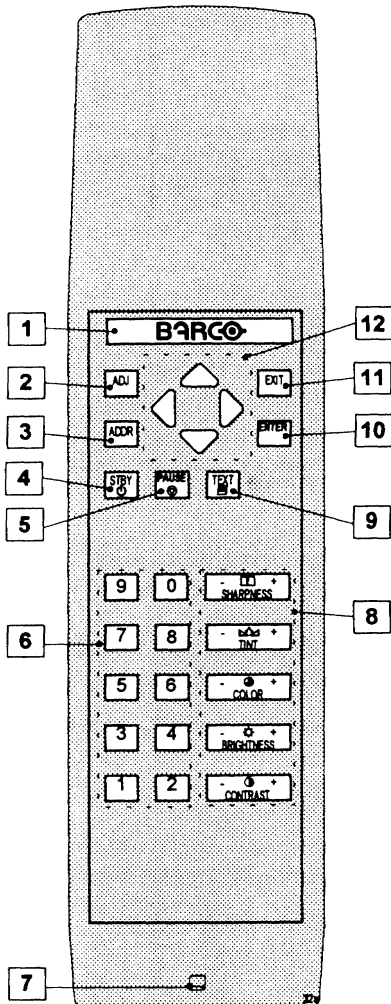

Other functions of the remote control are:

- switching between standby and operational modes
- switching to "pause" (blanked picture, full power for immediate restarting)
- direct access to all connected sources
- variable adjustment speed : when pushing continuously on the arrow keys or the picture keys, the adjustment will be executed in an accelerated fashion.

1 **Back light key** : when activated, all keys will be lit up and visible in the dark.

2 **ADJ.** : adjust key, to enter or exit the adjustment mode.

3 **ADDR.** : address key, to enter the address of the projector (between 0 and 9). Press 'ADDR', followed by pressing one digit button between 0 and 9.

4 **STBY** : stand by button : - to initiate remote power up operation
- to stop projection without main power off.

5 **PAUSE** : to blank the image, press PAUSE. The image disappears but full power is retained for immediate restarting.

6 **Digit buttons** : direct input selection.

7 **RC operating indication** : lights up when a button on the remote control is pressed. (This is a visual indicator to check the operation of the remote control)

8 **Picture controls** : use these buttons to obtain the desired level (see also 'Controlling') for each picture function.

9 **TEXT** : when adjusting one of the image controls during a meeting, the displayed bar scale can be removed by pressing 'TEXT' key first. To re-display the bar scale on the screen, press 'TEXT' key again. 'TEXT' key only active in operational mode. When 'TEXT' is off, no warning message will be displayed.

10 **ENTER** : to start up the adjustment mode or to confirm an adjustment or selection in the adjustment mode.

11 **EXIT** : to leave the adjustment mode or to scroll upwards when in the adjustment mode.

12 **ARROW keys** : to make menu selections when in the adjustment mode. Also allows to increment or decrement an adjustment in the adjustment mode.

POWER (MAINS) CONNECTION

Power (mains) cord connection

Use the supplied cord to connect your projector to the wall outlet. Plug the female power connector into the male connector at the back of the projector. This projector may be connected to an IT-power system.

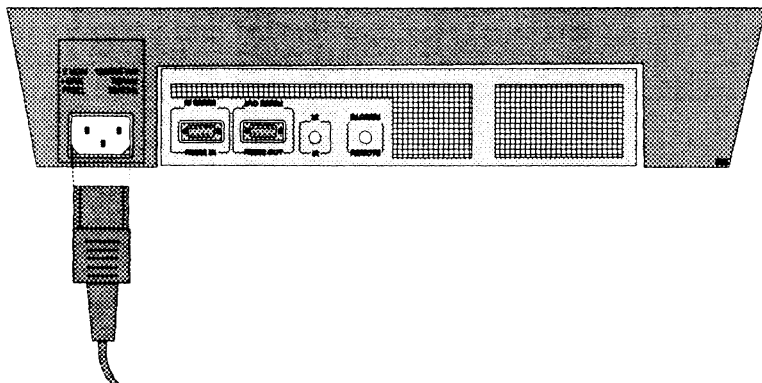

Power check

The power voltage for the projector is indicated on the identification plate on the rear of the projector.

Art. no. 90 00890 - 90 00891 has to operate on 230 V ac.

Art. no. 90 00898 - 90 00899 has to operate on 120 V ac.

If the indication is different from that of the wall outlet, call a qualified technician for power adaptation of the projector.

Switching on

The projector is switched ON and OFF using the power (mains) switch ON/OFF.

Pressed : ON

Not pressed : OFF

The projector can start now in the 'operational mode' (image displayed) or in the 'stand by mode', depending on the position of the 'power up' dip switch on the controller unit. This DIP switch is set during installation by a qualified technician. If you want to change this start up mode, call a qualified technician.

Power indication lamp :

OFF : no power

Green : projector in operational mode

Red : projector in stand by mode

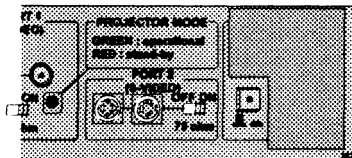

SOURCE CONNECTIONS

- **connecting a Video source**
- **connecting a S-Video source**
- **connecting a RGSB or RGBS analog source**

PERIPHERAL EQUIPMENT CONNECTION

- **connecting a RCVDS 800**
- **connecting an IR Remote Receiver**

Signal input connection to the projector :

- Composite Video
- S-Video
- RGSB or RGSB

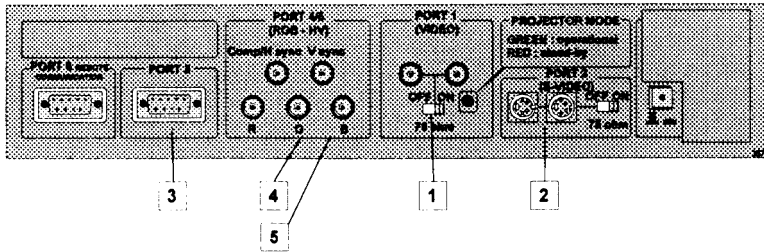

Source No	Projector input	Press digit button
1	Comp. Video	1
2	S-Video*	2
3	RGB analog	3
4	RGsB**	4
5	RGSB***	5

* Input signal Y/C (luma/chroma)

** Input signal : R, G and B with sync on G

*** Input signal : R, G and B with separate composite sync (S), or H+V sync

Connecting a Composite Video source to port 1.

Composite video signals from a VCR, OFF air signal decoder, etc...

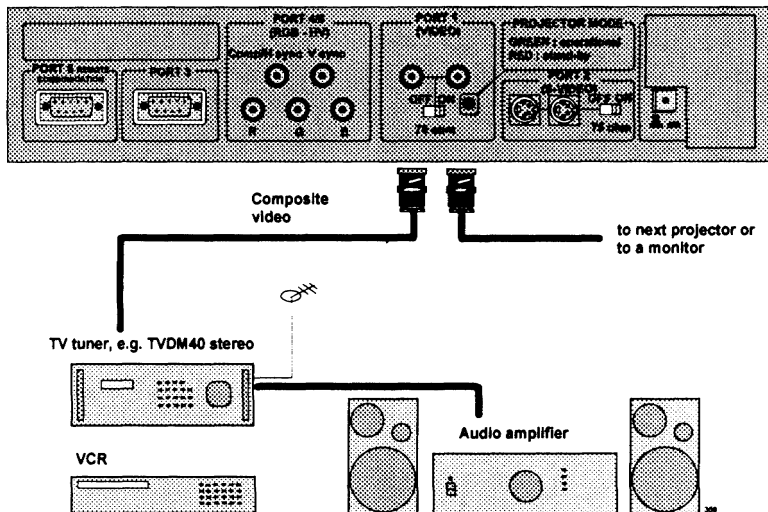

Video input selection :

Press digit button 1 on the RCU.

Connecting an S-Video source to port 2

Separate Y-luma/C-chroma signals for higher quality playback of Super VHS signals.

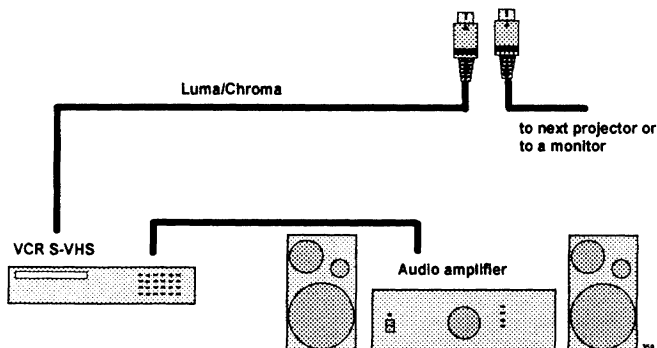
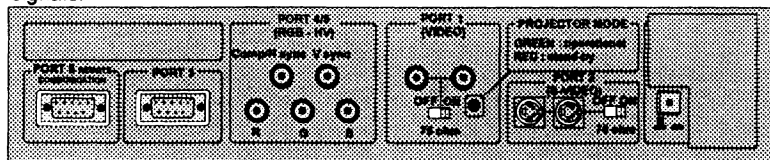

- Pin connection S-Video plug:
- pin 1 : ground Y (luma)
 - pin 2 : ground C (chroma)
 - pin 3 : Y (luma)
 - pin 4 : C (chroma)

S-Video input selection :

Press digit button 2 on the RCU.

Connecting a RGB Analog source to port 3.

Connect your Analog source via an interface to Port 3 (e.g. RGB 120 MHz interface, part number 98 26570).

RGB analog input with automatic sync detection. (Separate H and V sync inputs, with composite sync input or with sync signals on green.)

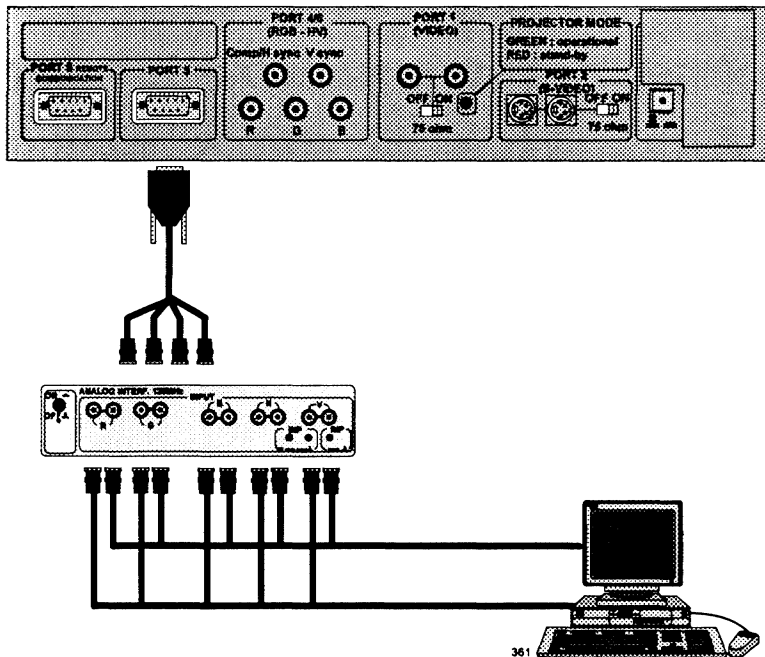

Pin configuration D9 connector of the Analog input.

- 1 not connected
- 2 ground RGBS
- 3 RED
- 4 GREEN
- 5 BLUE
- 6 ground RGBS
- 7 ground RGBS
- 8 Hor/comp. sync
- 9 Vert. sync

Analog input selection :
Press digit button 3 on the RCU800.

361

Connecting a RGB analog source to port 4/5.

RGB analog input terminals with separate H and V sync inputs, with composite sync inputs or with sync signals on green.

Always use an interface when a computer and local monitor have to be connected to the projector. Interfaces to be applied :

- universal analog interface. Order number : 98 26100.
- RGB 120 MHz analog interface. Order number : 98 26570.

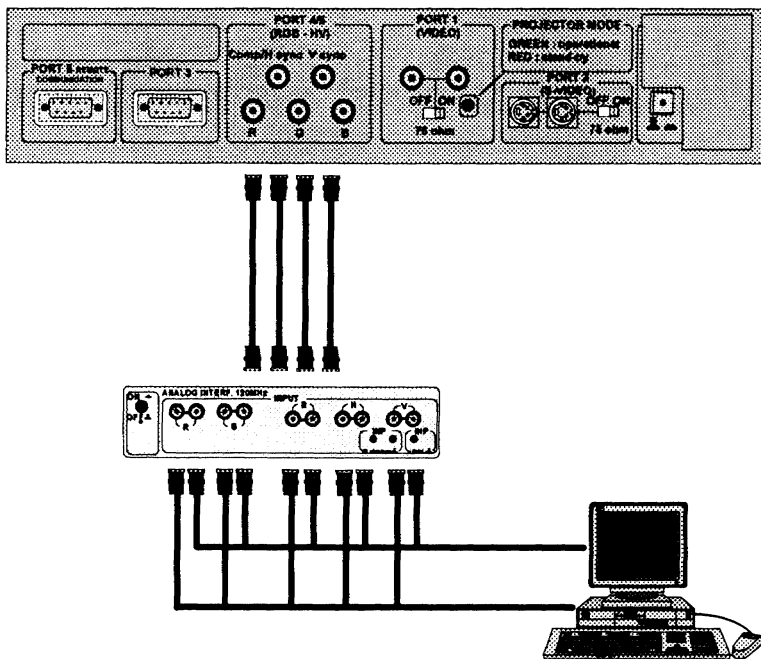

RGsB input selection :

(RGsB : R, G B signals with sync on green)

Press digit button 4 on the RCU.

RGBS input selection :

(RGBS : R, G, B and separate sync; H- and V- sync or comp. sync)

Press digit button 5 on the RCU.

PERIPHERAL EQUIPMENT**Connecting a RCVDS 800 to the BARCOGRAPHICS 1208.**

- Up to 10 inputs immediately accessible with the RCVDS 800 and up to 90 inputs accessible when 10 RCVDS 800's are connected in series.
- Serial communication with the projector.
- Remote control buttons on the RCVDS 800 to control the BARCOGRAPHICS 1208 (source selection and analog settings)
- The selected source number will be displayed on a 2 digit display and the selected input modules will be indicated with a LED on the rear.

For more information about the use of the RCVDS 800, consult the RCVDS 800 owner's manual, BARCO order number : 59 75004.

Connecting an IR Remote Receiver 800 to the BARCOGRAPHICS 1208.

This infra-red receiver unit makes it possible to control the BARCOGRAPHICS 1208 from another room. There is a communication line cable between the IR receiver and the projector or the RCVDS 800. The control information from the RCU can now be sent to the IR Remote Receiver 800. The IR Remote Receiver 800 displays the selected source on a 7-segment display.

Order number : 98 27515.

CONTROLLING

Battery installation

How to use your RCU

Projector address

How to display a projector address

How to program an address into the RCU

Input selection

Picture controls

Controlling chained projectors

Caution : Do not display a stationary image with high brightness and contrast for longer than 20 min., otherwise you risk damage to the CRT's.

Battery installation in the RCU.

A new battery (not yet installed to save the battery life time) is delivered inside the plastic bag with the power cord. Before using the RCU, start first the battery installation procedure.

Remove the battery cover on the backside of the remote control by pushing the indicated handle a little to the bottom of the RCU. Lift up the top side of the cover at the same time (fig. 1).

Insert the new 9 V battery (type 6F22S or equivalent) in the lower compartment and connect the battery to the contact plate.

Insert the battery into the lower compartment and put the cover back.

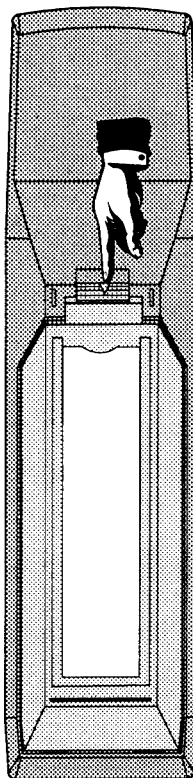
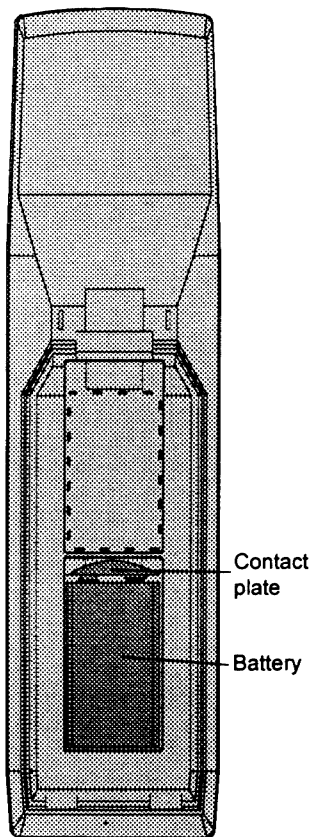

fig. 1



Contact
plate

Battery

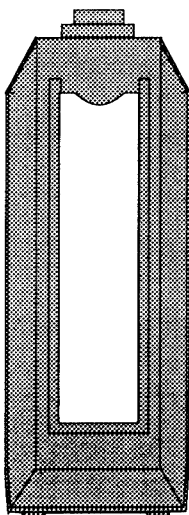

fig. 2

310a DRW

The BARCOGRAPHICS 1208 can be controlled with

- the RCU
- the hardwired RCU (cable not included)
- the projector's built-in RCU.

Controlling the projector with the RCU or the hardwired RCU is the same.

How to use your RCU

- Point the front of the RCU towards the reflective screen surface

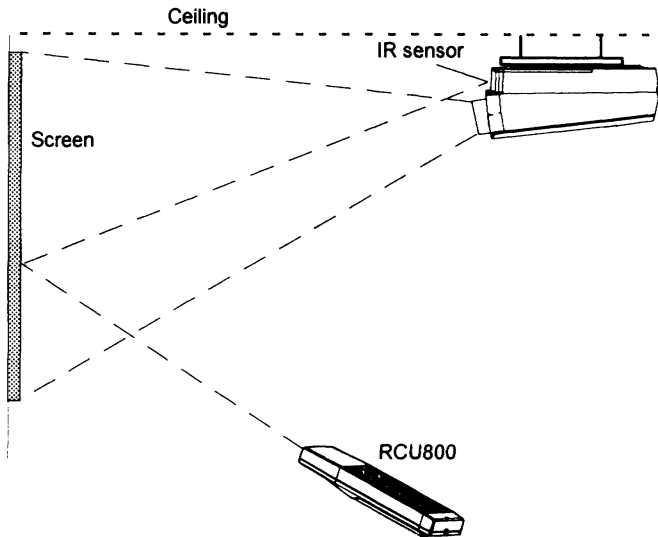

- Point the front of the RCU towards one of the IR sensor in the projector.

When using the wireless remote control, make sure you are within the effective operating distance (30m, 100ft in a straight line). The remote control unit will not function properly if strong light strikes the sensor window or if there are obstacles between the remote control unit and the projector's IR sensor.

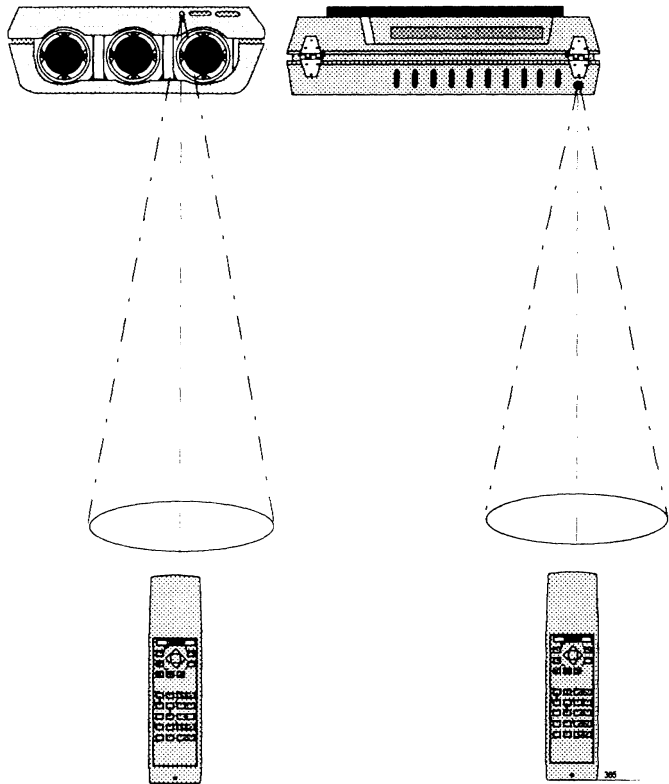

c) RCU used in a hardwired configuration.

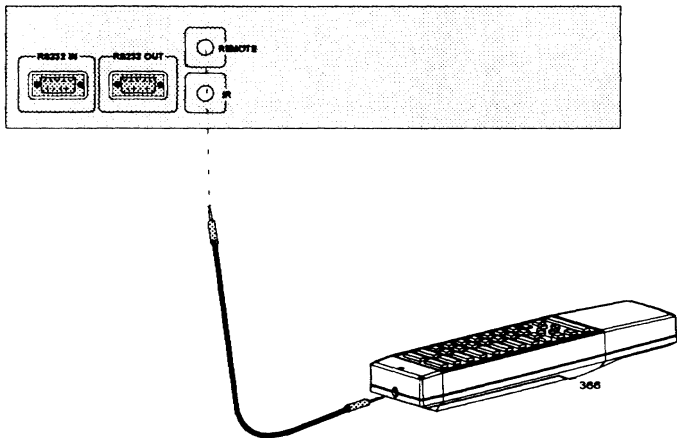

Plug one end of the remote cable (maximum 100 m, 320 ft) in the connector on the bottom of the RCU and the second side in the connector in the front panel of the BARCOGRAPHICS 1208 labelled 'REMOTE'.

d) Built in RCU.

This RCU is built into the rear of the projector. To gain access to it, push once on the door cover of the built in RCU and it will open. Now, it is possible to turn the RCU 90°.

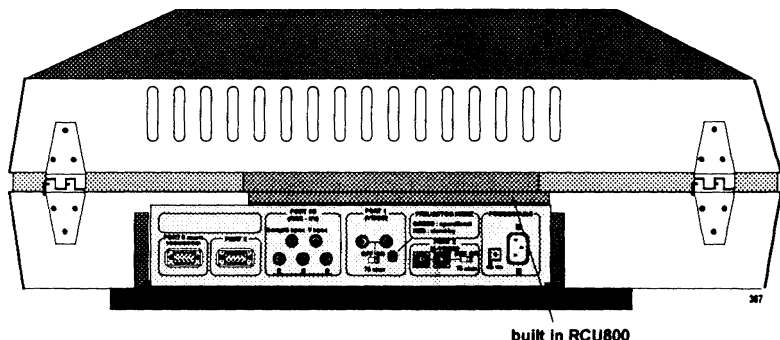

Projector address

a. hardware set up of the projector address.

Every projector requires an individual address between 0 and 255 which is set with hardware DIP switches inside the projector. To change that address, contact a BARCO authorized technician.

b. How to control the projector.

The projector's address may be set to any value between 0 and 255. When the address is set, the projector can be controlled now with :

- the RCU for addresses between 0 and 9.
- computer, e.g. IBM PC (or compatible), Apple MAC, etc. for addresses between 0 and 255.

Note : a projector will respond to an RCU set to an address of '0' regardless of what address is set in the projector itself.

c. Using your RCU.

Before using your RCU, it is necessary to enter the projector address into the RCU (only when that address is between 1 and 9). The projector with the corresponding address will listen to that specific RCU.

When address 0, 'zero address' is programmed into the RCU, every projector, without exception will listen to the commands given by this RCU.

How to display a projector address?

Press the ADDRESS key on the RCU.

The projector's address will be displayed in a 'Text box'. This text box disappears after a few seconds.

To continue using your RCU, it is necessary to enter an address with the digit buttons (address between 0 and 9).

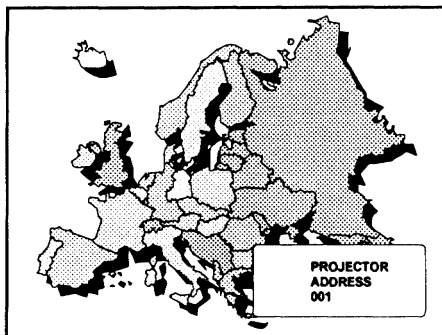

How to program an address into the RCU?

Press the ADDRESS key and enter the address with the digit buttons. That address can be any digit between 0 and 9.

When programming '0', zero address, the RCU will control a projector regardless of the projector's address. This feature allows multiple projectors with different addresses to be controlled by a single RCU.

Input selection

Source No	Projector input	Press digit button
1	Comp. Video	1
2	S-Video	2
3	RGB analog	3
4	RGsB	4
5	RGBS	5

With the digit buttons on the RCU, it is possible to select one of the four input sources, Video, S-Video, Analog, RGsB or RGBS.

When a valid and available source is selected, there will be information displayed on the screen about that source. This information includes :

- source number
- horizontal frequency
- vertical frequency

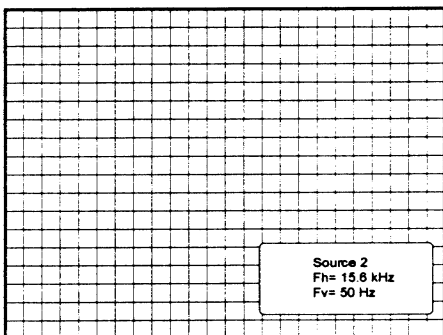

When the entry is a non valid source number, a warning appears on the

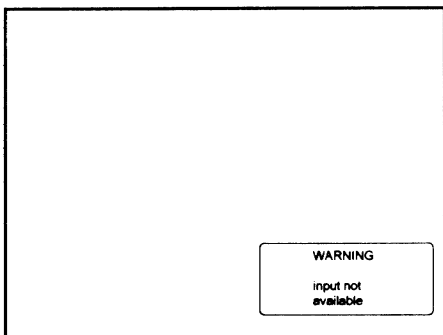

screen : '*input not available*'.

When a valid source number is selected, the projector will display this source or it will wait on the selected source number until the source becomes available. A message '*source not available*' will be displayed for a short time.

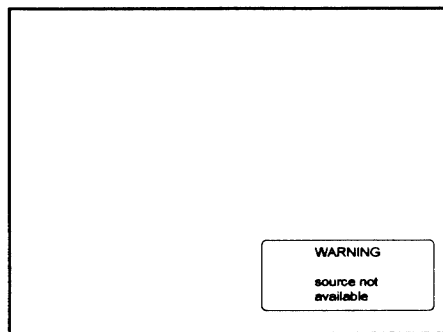

Picture controls

The picture controls can be adjusted with the RCU. The control keys are located on the right side of the key panel of the RCU and indicated with the name of the control and an icon.

When a picture control is pressed, a text box with a bar scale and function name of the control, e.g. 'brightness...' appears on the screen (only if text is ON). The length of the bar scale indicates the current memorized setting for this source. The bar scale changes as the + or - buttons of the control are pressed.

The picture controls can be adjusted with the RCU in 'adjustment mode' as well in 'operational mode'.

Brightness Control

A correct 'brightness' setting is important for good image reproduction.

Adjust the brightness with the + button and - button until the darkest parts of the picture appear black.

A bar scale gives a visual indication on the screen of the current brightness setting while pressing on the above indicated keys. If the bar scale is not visible on the screen, press 'TEXT' key once and retry the above indicated keys.

The bar scale increases when pressing on the + button (higher brightness) and decreases when pressing on the - button (lower brightness).

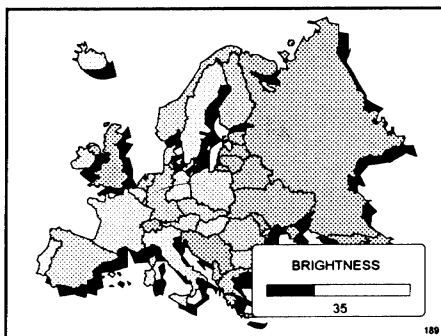

Contrast Control

A correct 'contrast' setting is important for good image reproduction.

Adjust the contrast to the level you prefer, according to room lighting conditions.

A bar scale gives a visual indication on the screen of the current contrast setting while pressing the + or - buttons. If the bar scale is not visible on the screen, press 'TEXT' key once and retry the above indicated keys.

The bar scale increases when pressing on the + button (higher contrast) and decreases when pressing on the - button (lower contrast).

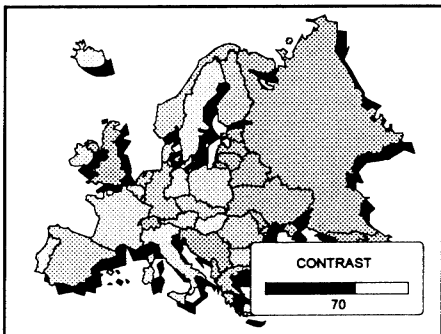

Color Saturation Control

Color saturation is only active for Video and S-Video. Adjust the color intensity of the picture. Adjust the color saturation using the + and - buttons. A bar scale gives a visual indication on the screen of the current color setting while pressing on the above indicated keys. If the bar scale is not visible on the screen, press 'TEXT' key once and retry the above indicated keys. The bar scale increases when pressing on the + button (richer colors) and decreases when pressing the - button (lighter colors).

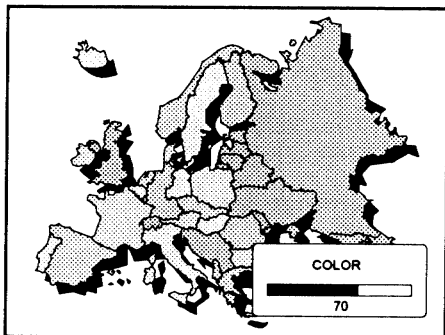

Tint Control

Tint is only active for Video and S-Video. Tint control is effective only when using the NTSC 4.43 or NTSC 3.58 system. A bar scale gives a visual indication on the screen of the current tint setting while pressing the + or - buttons. If the bar scale is not visible on the screen, press the 'TEXT' key once and retry the above indicated keys.

The bar scale increases when pressing on the + button (greener skin tones) and decreases when pressing the - button (more purple skin tones).

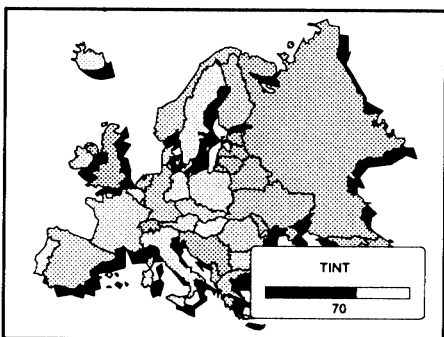

Sharpness Control.

Sharpness control is only active for Video and S-Video. A bar scale gives a visual indication on the screen of the current sharpness setting while pressing the + or - buttons. If the bar scale is not visible on the screen, press 'TEXT' key once and retry the above indicated keys.

The bar scale increases when pressing on the + button (sharper picture) and decreases when pressing on the - button (softer picture).

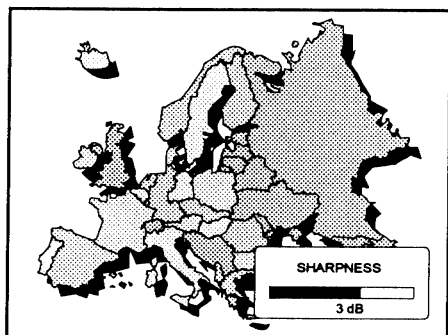

Controlling chained projectors.

Projectors can be controlled individually as well as in a group.

For individual control see previous pages.

For group control of the projectors.
(Input selection and analog picture control.)

Program the 'zero address' into any RCU. Therefore, press on the address key and key in the address with the numeric keys on the RCU itself.

Once address '0' is pressed, all projectors will be controlled together until a new address is entered on the RCU. It is possible to have a common input selection and a common analog picture control.

Once a new address is entered, only the projector with that specific address will follow the new instructions (1 to 9).

Note : For group control, all projectors in a control group must be capable of receiving the IR signal from the controlling RCU at the same time.

START UP OF THE ADJUSTMENT MODE

START UP OF THE ADJUSTMENT MODE

START UP OF THE ADJUSTMENT MODE

Start up of the adjustment mode.

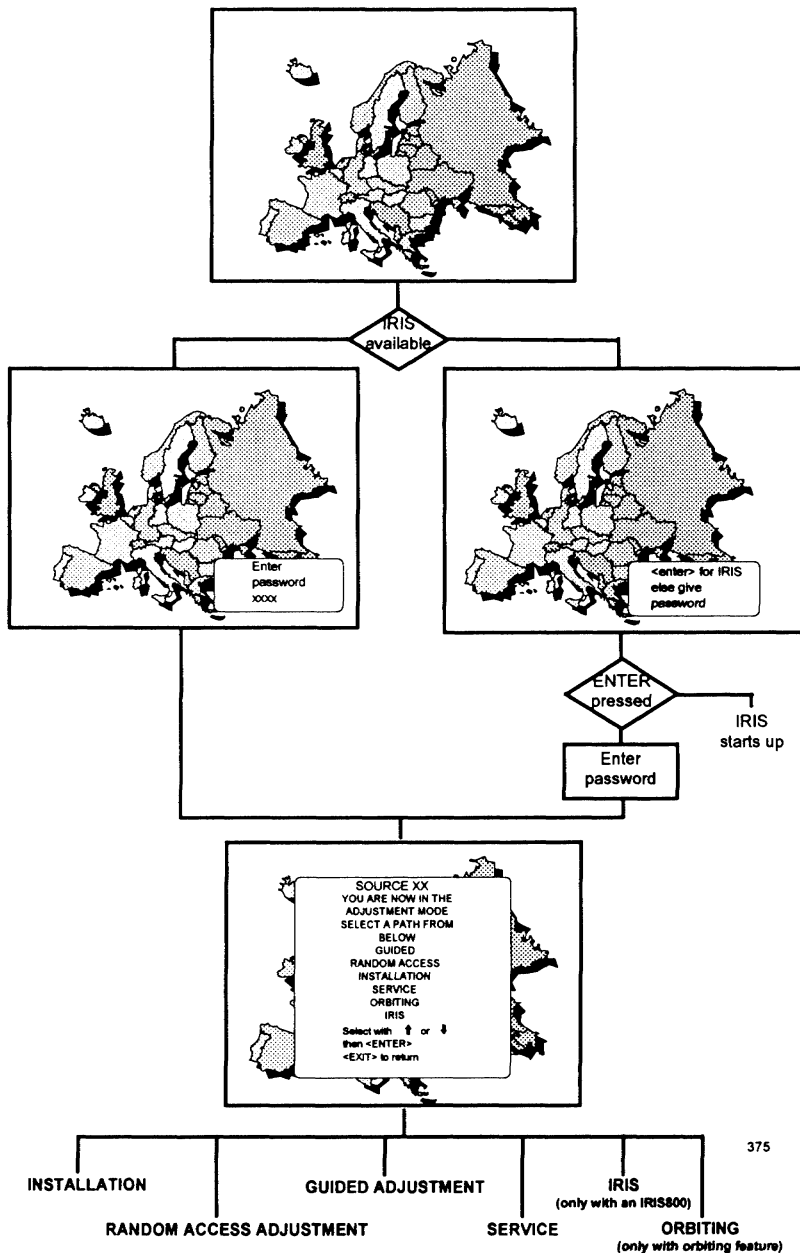

START UP OF THE ADJUSTMENT MODE

Adjustment mode.

All picture geometry and convergence adjustments are made while in the 'Adjustment mode'. Only the automatic convergence adjustments with IRIS 800, if installed, are not password protected when entering the adjustment mode.

Enter the adjustment mode by pressing the **ADJUST** key on the RCU800. Depending on your configuration and if the password function is enabled, the projector displays:

- a. IRIS start up/password menu.
or
- b. enter password menu.

- a. IRIS start up/password menu

If your projector is equipped with the optional IRIS 800 autoconvergence unit, it will display the IRIS start up/password menu when **ADJUST** is pressed in the operational mode.

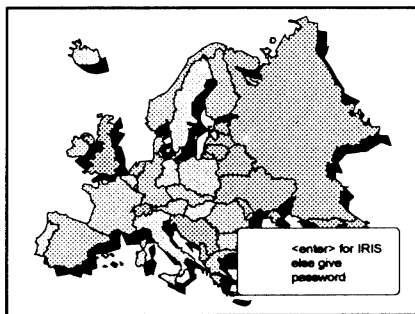

ENTER : starts up the IRIS 800.
EXIT : returns to operational mode.

- * if you only want to converge the image, press **ENTER** to start up the autoconvergence unit IRIS 800. Follow the instructions as described in the IRIS 800 owner's manual.

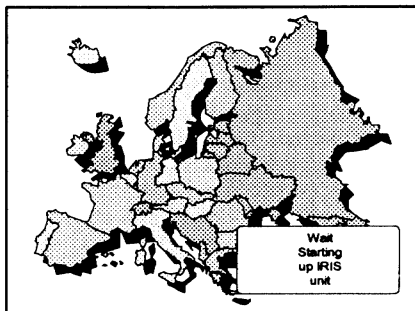

378

START UP OF THE ADJUSTMENT MODE

* If you have to make other adjustments or you want to converge manually, enter your password to start up the adjustment mode.

Your password contains 4 digits. Enter the digits with the numeric keys on the RCU.

When your password is correct, you gain access to the 'Adjustment Mode'.

When the entered password is wrong, the following message will be displayed in a text box : 'invalid code entry'. The projector stays in operational mode.

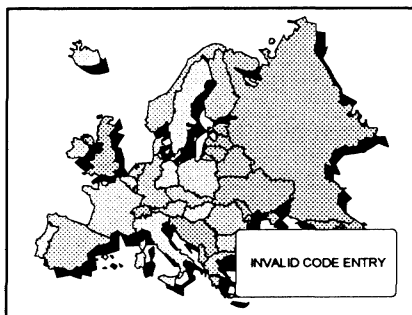

377

b. Enter password menu.

Your projector is not equipped with an IRIS 800 unit. When the ADJUST key is pressed, the enter password menu will be displayed. Enter your password to get access to the adjustment mode.

Your password contains 4 digits. Enter the digits with the numeric keys on the RCU.

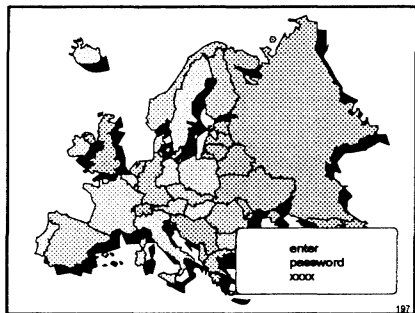

187

When your password is correct, you gain access to the 'Adjustment mode'.

When the entered password is wrong, the following message will be displayed in a text box : 'invalid code entry'. The projector stays in operational mode.

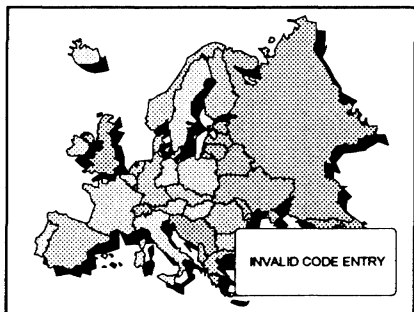

377

Adjustment mode

You are now in the Adjustment Mode. The arrow keys are used to make menu selections and also vertical and horizontal adjustments. The **ENTER** and **EXIT** keys are used to move forward and backward through the menu structure. The **ADJUST** key can be used to terminate the adjustment mode while a path selection menu (head menu) is displayed.

Depending on your projector's configuration, there are 6 possible paths once in the adjustment mode.

- **INSTALLATION** - Installation should be selected if the projector has been relocated and/or a different screen size is desired. The user is instructed to make basic mechanical adjustments to the projector and may then proceed to either the Guided Adjustment Mode or the Random Access Adjustment Mode.

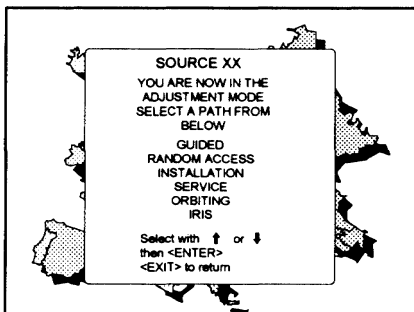

- **GUIDED** - Guided should be selected if the user intends to perform a complete alignment of the projected image. All of the necessary geometry and convergence adjustments are made in a predetermined sequence.

- **RANDOM ACCESS** - Random access should be selected if the user intends to make only a few adjustments.

- **SERVICE** - Service should be selected if the user intends to delete blocks, copy blocks, change password, set to mid position or apply for information.

- **ORBITING** - This selection is only available when the orbiting feature is built into the projector. The purpose of the orbiting feature is to avoid burning in the CRT's when displaying a stationary image with high brightness and contrast for a long time (> 20 min).

- **IRIS** - This selection will only be available when the autoconvergence unit IRIS 800 is connected to the projector. The purpose of this unit is to converge automatically the image of the connected source or sources.

While in Guided or Random Access adjustment mode, the user may use an external source, an internally generated genlocked pattern or an internally generated multifrequency cross hatch pattern as a setup pattern.

START UP OF THE ADJUSTMENT MODE

START UP OF THE ADJUSTMENT MODE

GUIDED ADJUSTMENT MODE

Start up of the guided adjustment mode.

Use the arrow keys to highlight *GUIDED* on the Path selection menu and then press **ENTER**.

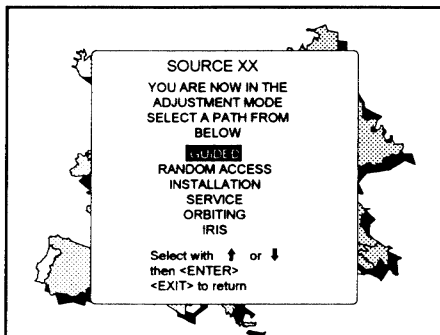

208a

ENTER continues to the Setup Pattern Selection
EXIT returns to operational mode.
ADJUST returns to operational mode.

Overview flowchart 'Guided Adjustment' procedure.

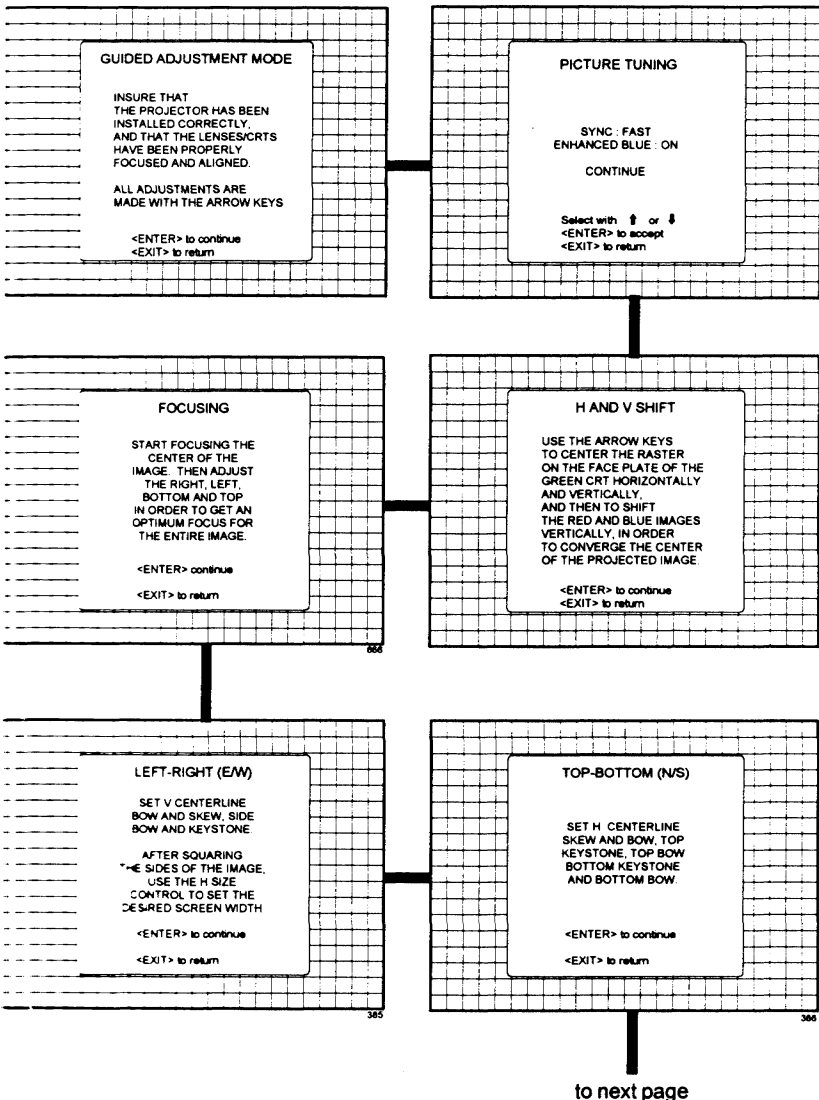

from previous page

SIZE-LINEARITY

ADJUST THE H SIZE,
V SIZE AND V
LINEARITY IN ORDER
TO SET THE DESIRED
IMAGE DIMENSIONS

USE THE H PHASE
CONTROL TO SHIFT
THE IMAGE WITH
RESPECT TO THE RASTER

<ENTER> to continue
<EXIT> to return

387

CONVERGENCE

START WITH GREEN ONLY,
THEN RED ON GREEN,
THEN BLUE ON GREEN.
USE THE ARROW KEYS FOR
HORIZONTAL AND VERTICAL
ADJUSTMENTS IN THE AREA
INDICATED BY THE BOX.

<ENTER> WILL MOVE
THE BOX TO THE NEXT AREA
TO BE CONVERGED, AND
<EXIT> WILL MOVE IT BACK
TO THE PREVIOUS.

<ENTER> to continue
<EXIT> to return

WHITE BALANCE

3200 6500 9500
CUSTOM
SELECT A DESIRED
COLOR TEMPERATURE
THEN <ENTER>

ADJUST
RED TEMPERATURE
WITH ↑ OR ↓
BLUE WITH ← OR →

<ENTER> CONTINUE
<EXIT> TO RETURN

388

BLANKING

ADJUST THE TOP,
BOTTOM, LEFT AND
RIGHT BLANKING
IN ORDER TO FRAME
THE PROJECTED
IMAGE ONTO THE
SCREEN.

<ENTER> to continue
<EXIT> to return

388

BLACK BALANCE

ADJUST THE RED CUT OFF
WITH ↑ OR ↓ AND THE
BLUE CUT OFF WITH ← OR →
IN ORDER TO GET THE
DESIRED COLOR
TEMPERATURE FOR LOW
INTENSITIES.

THIS PROCEDURE WILL
CONCLUDE THE GUIDED
ADJUSTMENT SEQUENCE

<ENTER> CONTINUE
<EXIT> TO RETURN

390

Selecting Setup Pattern

If an external source is connected to the projector, Setup pattern menu will be displayed. Use the arrow keys to highlight the desired setup pattern and then press **ENTER**.

Genlocked pattern : internally generated cross hatch pattern, locked on the external source.

Internal # pattern : internally generated cross hatch pattern and locked on internal generated sync signals. (No external source necessary)

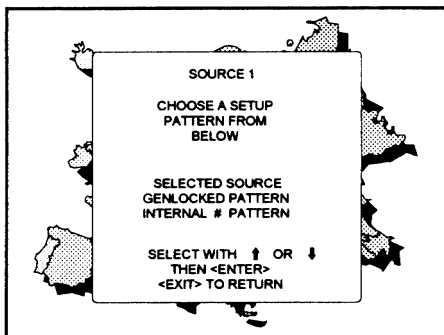

391

ENTER continues to Guided Adjustment Mode menu or Internal # Pattern Selection menu

EXIT returns to Path Selection

ADJUST returns to operational mode

If no external source is connected to the projector, the internal cross hatch pattern menu will be displayed.

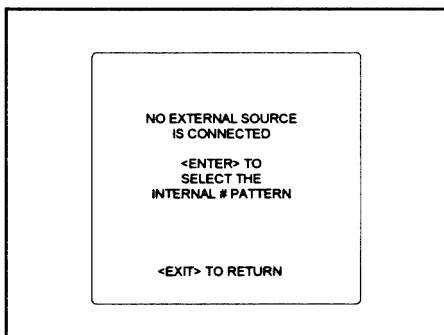

392

ENTER displays the internal # pattern menu.
EXIT returns to the Path selection menu.

The menus in this manual are created for an external source, connected to one of the inputs, and the 'Genlocked pattern' is selected.

Internal Cross Hatch Pattern

The Internal # pattern menu will be displayed if the internal cross hatch pattern has been selected or if no source is connected to the projector.

The table below lists the 8 factory preset frequencies available.

Use the arrow keys to highlight the desired cross hatch frequency and then press **ENTER**.

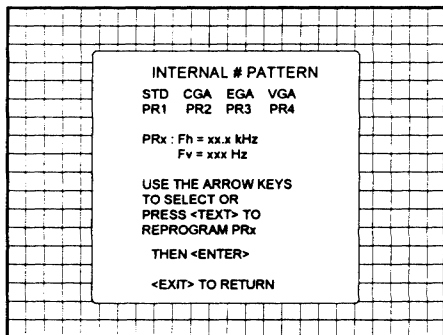

STD : Fh = 15.6 kHz	Fv = 50 Hz
CGA : Fv = 15.7 kHz	Fv = 60 Hz
EGA : Fv = 21.9 kHz	Fv = 60 Hz
VGA : Fv = 31.5 kHz	Fv = 60 Hz
PR1 : Fv = 48.0 kHz	Fv = 60 Hz
PR2 : Fv = 64.0 kHz	Fv = 70 Hz
PR3 : Fv = 90.0 kHz	Fv = 50 Hz
PR4 : Fv = 128.0 kHz	Fv = 60 Hz

ENTER continues to the Guided Adjustment mode menu.

EXIT returns to Setup Pattern Selection menu.

TEXT gives the reprogram menu.

It is possible to store user defined cross hatch frequencies in PR1 - PR4. Handle as follows to program a custom cross hatch frequency.

1. highlight the desired storage location (PR1-PR4) on the Internal # pattern menu.
2. Press **TEXT** to reprogram.
3. Use the arrow keys to select the digits to be changed.
4. Reprogram the desired horizontal frequency as xx.x kHz and the vertical frequency as xxx Hz using the numeric keys.
5. Press **ENTER** to confirm.

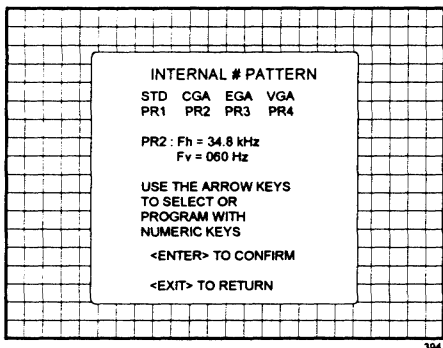

ENTER confirms your entry and continues to Guided Adjustment mode menu.

EXIT returns to Setup Pattern Selection menu.

GUIDED ADJUSTMENT MODE

Example : Desired cross hatch frequency :

Fv = 34.8 kHz

Fh = 60 Hz

Use the arrow keys to highlight the desired storage location (PR1-PR4) and press **TEXT**. The program menu appears on the screen. Use the arrow keys to go to the first digit of the horizontal frequency and press.

3 4 8 0 6 0 <ENTER>

Note : enter always 6 digits

In the example, an 0 is added between the last significant digit of the hor. freq. and the first significant digit of the vert. freq. to complete the 6 digits.

Note: Before continuing, insure that the lenses are properly focused and that the CRT projection angle is correctly adjusted. If any misalignment is noticed, consult a qualified service technician.

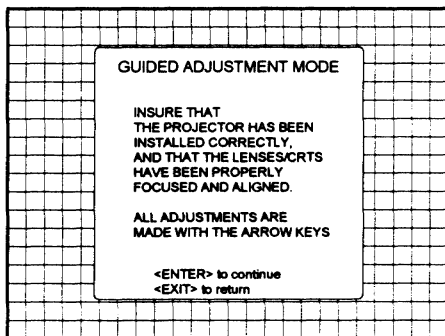

ENTER continues with the Picture Tuning
EXIT returns to Setup Pattern Selection or
Internal # Pattern Selection
ADJUST returns to operational mode

Picture tuning toggle switches.

Depending on the source type (video, S-Video, RGB(S) analog with composite) the picture tuning menu offers the possibility to toggle :

for Video or S-Video sources :

- the Synchronisation speed

for RGB analog with composite sync or sync on green sources:

- enhanced blue on or off
- the Synchronisation speed

Sync Fast/Slow toggle

Highlight *Sync* with the arrow keys and press **ENTER** to toggle between FAST and SLOW

Note : SYNC is normally used in the SLOW position. The FAST position is used to compensate for unsteady sync pulses from older video playback equipment.

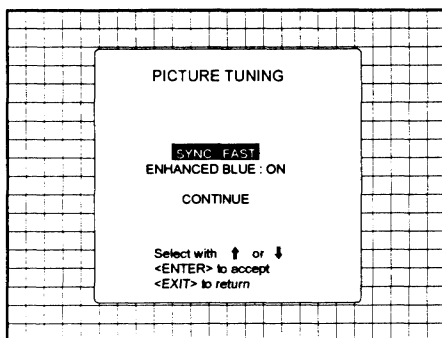

Enhanced blue ON/OFF

Highlight *Enhanced Blue* with the arrow keys and press **ENTER** to toggle between ON and OFF (only available when RGB analog signals are connected to the projector).

When Enhanced Blue is ON, the blue color will be displayed as cyan.

Note : Enhanced blue is only used when an RGBS or RGsB analog signal from a computer is being displayed. Enhanced blue is not recommended for non computer generated images.

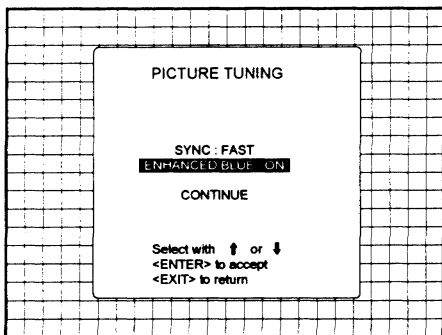

ENTER will toggle Enhanced Blue between ON and OFF.
EXIT will return to the white balance menu.

For displaying graphics, this Enhanced Blue function could falsify the color reproduction. In this case, put Enhanced Blue OFF

Raster Centering on Green CRT Faceplate

The green raster must be centered both horizontally and vertically on the center of the CRT surface. To center the green raster, look into the green lens and use the arrow keys to move the raster.

Caution

It is necessary to look into the lenses to perform these adjustments. To avoid eye discomfort while looking into the lenses, reduce the contrast and gradually increase the brightness level until the raster becomes visible.

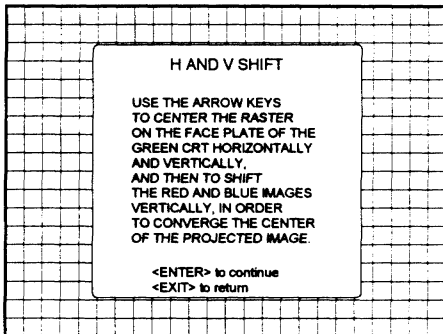

ENTER continues to Green Raster Shift
EXIT returns to Guided Adjustment Mode
ADJUST returns to operational mode

Warning : In order to ensure maximum CRT longevity and to avoid CRT damage, do not shift the raster outside the phosphor area of the CRT.

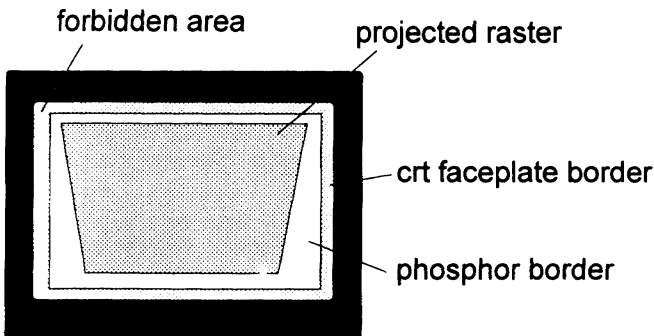

234

To begin the adjustment, press the ENTER key.

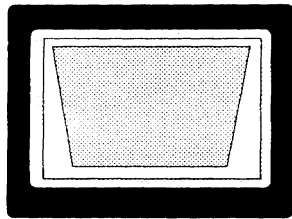

correct raster position

wrong raster position

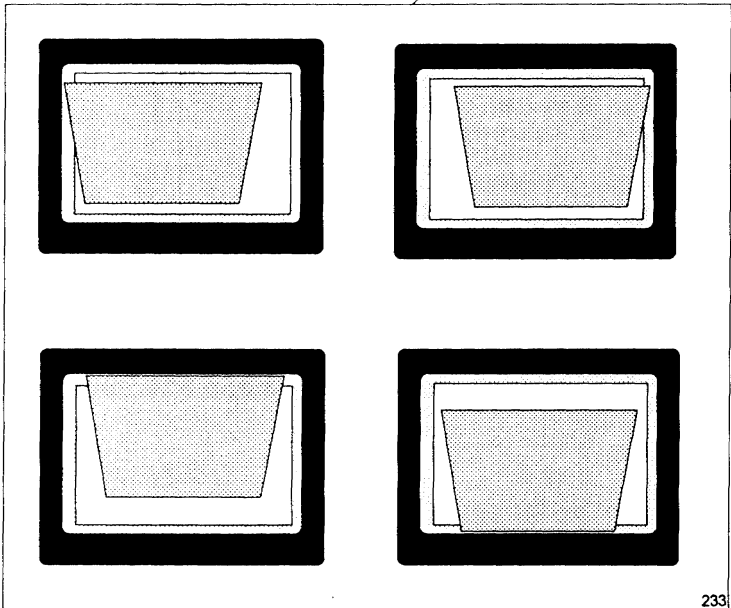

After centering the green raster, press the **ENTER** key to continue.

ENTER continues to Red Raster Shift
EXIT returns to Horizontal and Vertical Shift menu.

Shifting Red and Blue on Green

Use the arrow keys to shift the red image until the center coincides with the center of the green image.

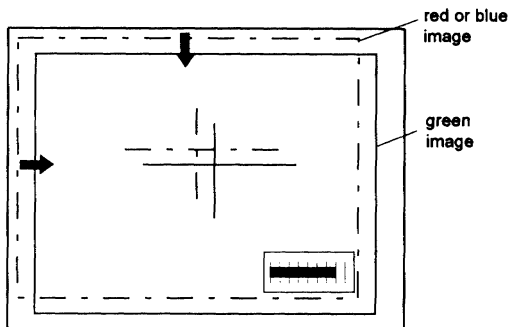

When the red image is correctly positioned, press the **ENTER** key to continue with the blue image.

ENTER continues to blue raster shift
EXIT returns to green raster shift

Focusing

Before starting the Focusing adjustment, be sure the lenses are correctly focused.

The software will guide you to adjust the following adjustments

Midpoint focusing
top image focusing
bottom focusing
left focusing
right focusing

First will be started with Green image, then with the Red and then with the Blue image.

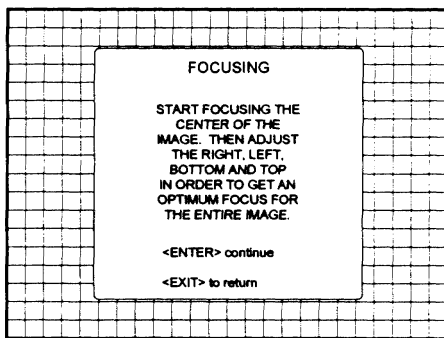

ENTER continues to the focusing adjustment.
EXIT returns to the shift adjustment.

Midpoint focusing

Adjust with the left and right arrow keys until the center of the image is sharp.
Press **ENTER** to continue to the Top image focusing.

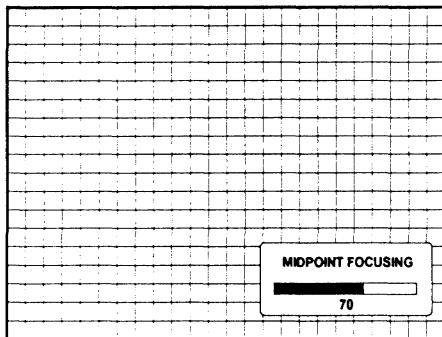

ENTER continues with the Top image focusing.
EXIT returns to the shift adjustment.

Top image focusing.

Use the left and right arrow keys to adjust the top focusing. Adjust until the upper part of the image is sharp.
Press **ENTER** to continue with the bottom image focusing.

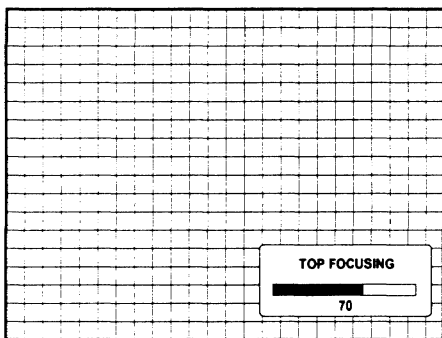

ENTER continues with the bottom image focusing.
EXIT returns to the midpoint image focusing.

GUIDED ADJUSTMENT MODE

Bottom image focusing.

Use the left and right arrow keys to adjust the bottom focusing. Adjust until the lower part of the image is sharp.

Press **ENTER** to continue with the left image focusing.

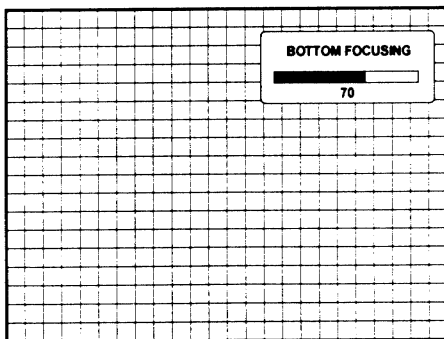

ENTER continues with the left image focusing.

EXIT returns to the top image focusing.

Left image focusing.

Use the left and right arrow keys to adjust the left focusing. Adjust until the left part of the image is sharp.

Press **ENTER** to continue with the right image focusing.

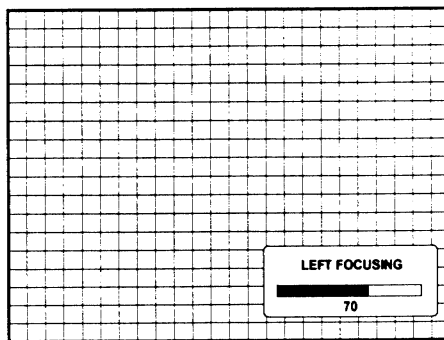

ENTER continues with the right image focusing.

EXIT returns to the bottom image focusing.

Right image focusing.

Use the left and right arrow keys to adjust the left focusing. Adjust until the right part of the image is sharp.

Press **ENTER** to continue with the midpoint focusing of the red image.

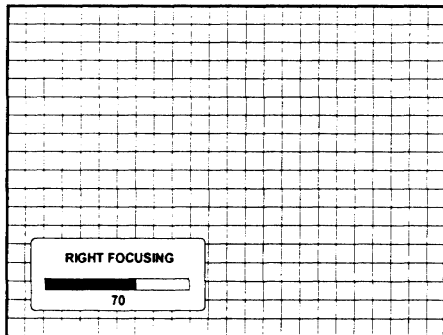

671

ENTER continues with the midpoint image focusing of the red image.
EXIT returns to the bottom image focusing.

The focusing procedure from midpoint focusing to right image focusing will be repeated first for the red image and secondly for the blue image.

Left-Right (East-West) Adjustments

Left-right adjustments affect only the vertical lines of the setup pattern. Only the green image is displayed while making left-right adjustments. The red and blue images will automatically be corrected in the same manner.

Convergence corrections are automatically disabled for the duration of these adjustments.

Press the **ENTER** key to continue.

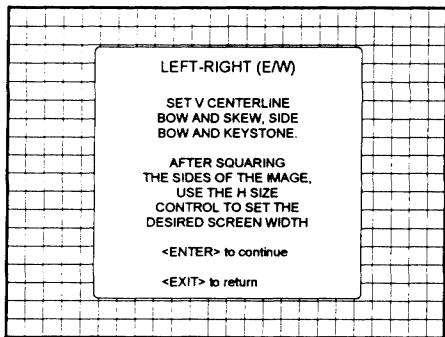

385

ENTER continues to vertical centerline bow adjustment
EXIT returns to Raster Centering
ADJUST returns to operational mode

Vertical Centerline Bow Adjustment

The vertical centerline bow adjustment corrects for curvature in the horizontal direction in the middle of the picture for the vertical lines.

Use the left or right arrow key to adjust the vertical centerline bow of the setup pattern and then press the **ENTER** key to continue.

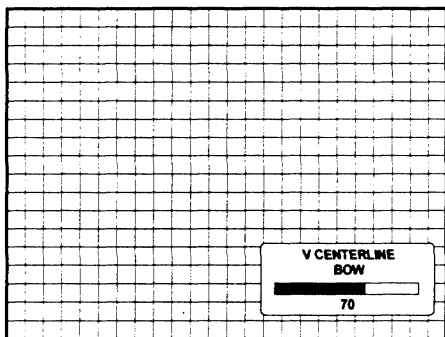

ENTER continues to vertical centerline skew adjustment
EXIT returns to Left-Right adjustments

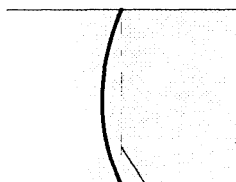

Vertical centerline

Correct with right
arrow key

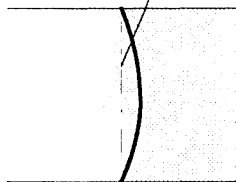

Correct with left
arrow key

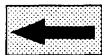

Vertical Centerline Skew Adjustment

The vertical centerline skew adjustment corrects for tilting of the vertical lines in the middle of the screen.

Use the left or right arrow key to adjust the vertical centerline skew of the setup pattern until this line is straight. Misalignment of the outer vertical lines will be corrected with the side bow and keystone corrections. Press **ENTER** to continue.

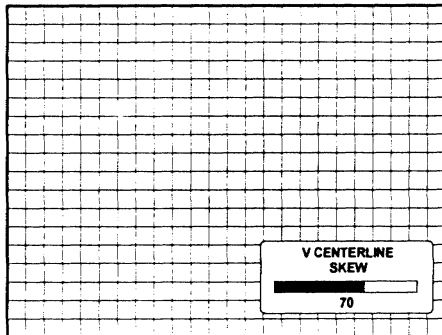

ENTER continues to side keystone adjustment
EXIT returns to vertical centerline bow adjustment

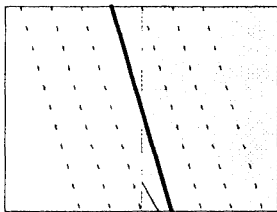

Correct with right
arrow key

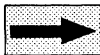

Vertical centerline

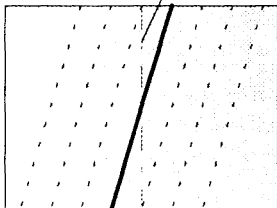

Correct with left
arrow key

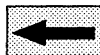

Side Keystone Adjustment

The side keystone adjustment corrects the keystone geometry distortion of the vertical lines on the sides of the image.

Use the left or right arrow key to adjust the side keystone (vertical lines) of the setup pattern and press **ENTER** to continue

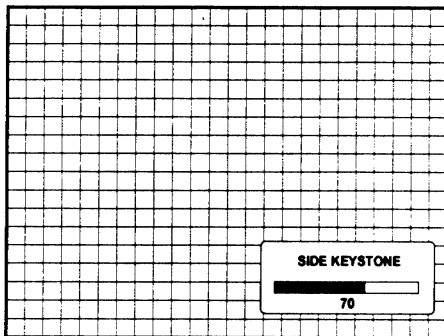

ENTER continues to side bow adjustment
EXIT returns to side keystone adjustment

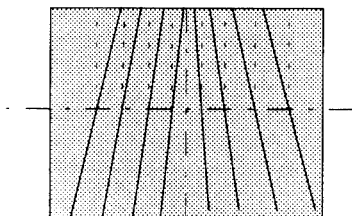

Correct with right
arrow key

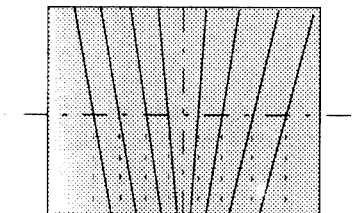

Correct with left
arrow key

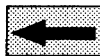

Side Bow Adjustment

The side bow adjustment corrects for curvature occurring at the sides of the displayed image for the vertical lines. Use the left or right arrow key to adjust the side bow of the setup pattern (vertical lines) and press **ENTER** to continue.

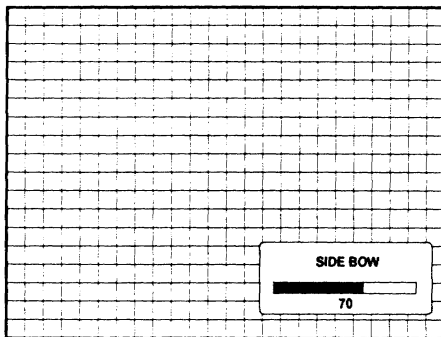

405

ENTER continues to H. ampl. adjustment
EXIT returns to side keystone adjustment

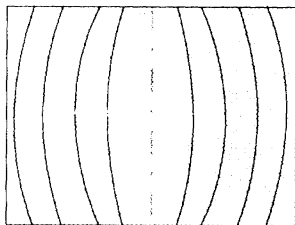

Correct with right
 arrow key

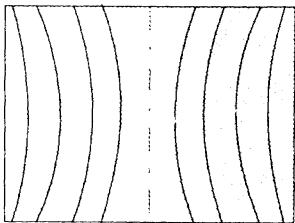

Correct with left
 arrow key



-horizontal Size Adjustment

Adjust the horizontal size with the left and right arrow keys until the correct image width is obtained.

Note :

- if the internal # pattern was selected, this pattern remains on the screen.
- if the genlocked pattern was selected, the external source will be displayed.

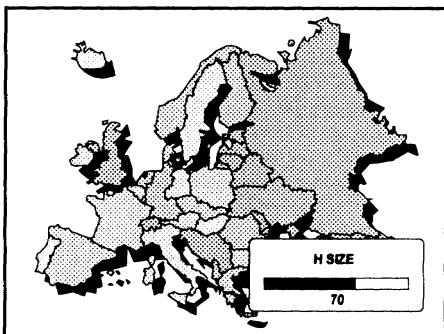

A bar scale and a number indicator (between 0 and 100) give a visual indication of the horizontal size adjustment.

Hint : In order to avoid loss of resolution in the projected image and to ensure maximum CRT longevity, do not use an excessively small horizontal size setting on the CRT faceplate. Consult your dealer for the correct installation position of your projector.

ENTER continues to Top-Bottom adjustments

EXIT returns to side bow adjustments

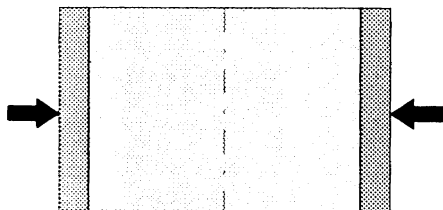

Correct with left arrow key

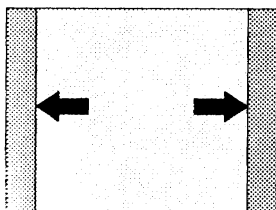

Correct with right arrow key



Top-Bottom (North-South) Adjustments

Top-Bottom adjustments affect only the horizontal lines of the setup pattern. These adjustments are performed only on the green image. The red and blue images are automatically corrected in the same manner.

Convergence corrections are automatically disabled for the duration of these adjustments.

Press the **ENTER** key to continue.

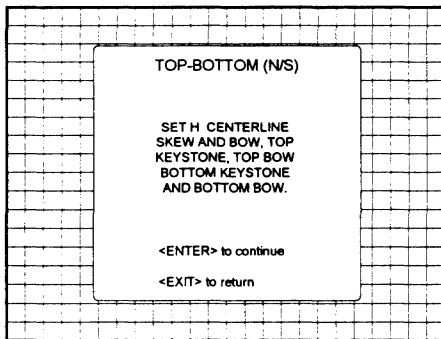

ENTER continues to horizontal centerline skew adjustment
EXIT returns to Left-Right adjustments
ADJUST returns to operational mode

Horizontal Centerline Skew Adjustment

The horizontal centerline skew adjustment corrects for tilting of the horizontal lines in the middle of the screen.

Use the up and down arrow keys to adjust the horizontal centerline skew of the setup pattern.

A bar scale and a numeric indicator (between 0 and 100) will give a visual indication of the skew correction.

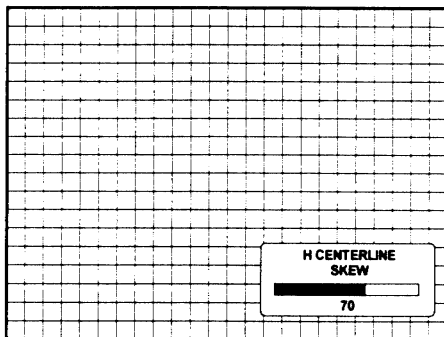

ENTER continues to horizontal centerline bow adjustment.
EXIT returns to Top-Bottom Adjustments

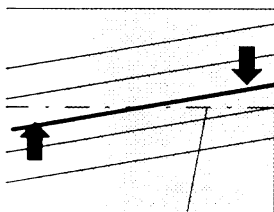

Hor. centerline

Correct with up arrow key

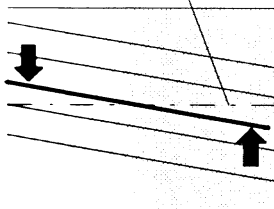

Correct with down arrow key



Horizontal Centerline Bow Adjustment

The Horizontal centerline bow adjustment corrects for curvature in the vertical direction in the middle of the picture for the horizontal lines.

Use the up and down arrow keys to adjust the horizontal centerline bow of the setup pattern.

A bar scale and a numeric indicator (between 0 and 100) will give a visual indication of the bow correction.

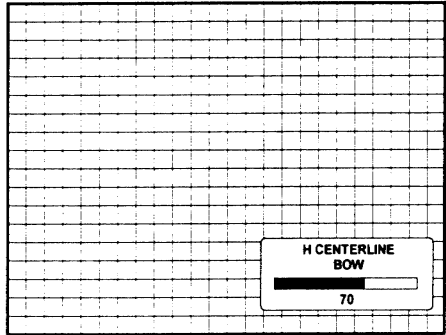

ENTER continues to top keystone adjustment
EXIT returns to Top-Bottom Adjustments

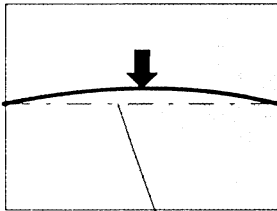

Correct with
down arrow key

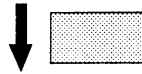

Hor. centerline

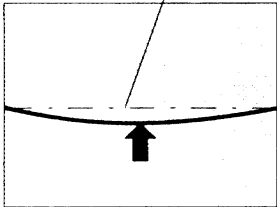

Correct with up
arrow key



∞ Keystone Adjustment

The top keystone adjustment corrects for keystone geometry distortion of the horizontal lines in the upper part of the image.

Adjust with the arrow keys until these lines are straight. Press **ENTER** to continue.

A bar scale and a number indicator (between 0 and 100) will give a visual indication of the keystone correction.

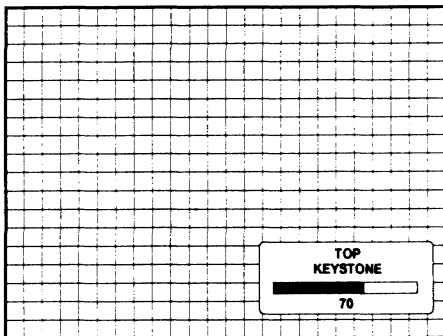

ENTER continues to top bow adjustment
EXIT returns to horizontal centerline bow adjustment

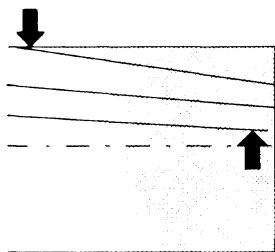

Correct with up arrow key

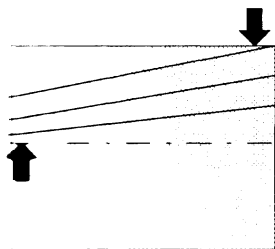
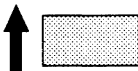

Correct with down arrow key



Top Bow Adjustment

The top bow function corrects for curvature occurring in the upper part of the image.

Adjust the bow of the horizontal lines in the upper side of the image with the arrow keys until these lines are straight. A bar scale and a number indicator below indicate the amount of adjustment.

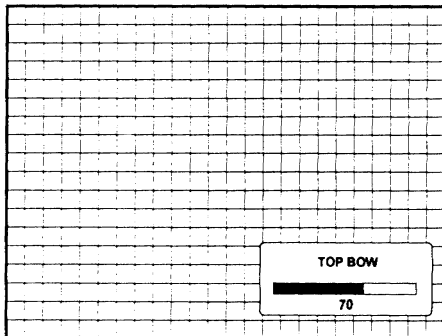

ENTER continues to bottom keystone adjustment

EXIT returns to top keystone adjustment

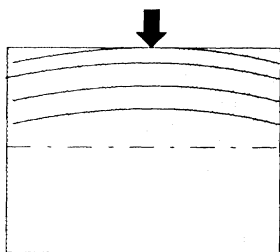

Correct with up
arrow key

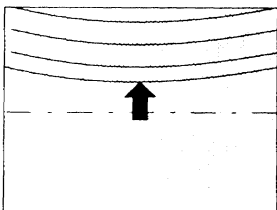
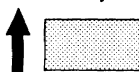

Correct with
down arrow key



Bottom Keystone Adjustment

The bottom keystone function corrects for keystone geometry distortion of the horizontal lines in the lower part of the image.

Adjust with the arrow keys until these lines are straight.

A bar scale and a number indicator (between 0 and 100) will give a visual indication of the adjustment.

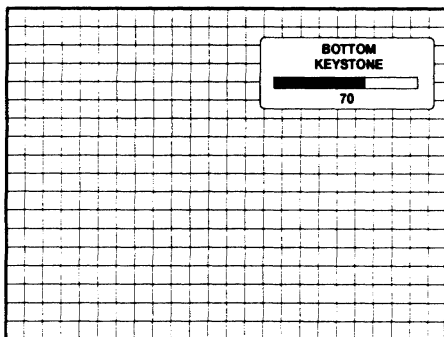

ENTER continues to bottom bow adjustment

EXIT returns to top bow adjustment

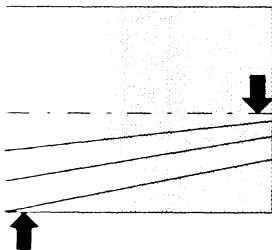

Correct with up arrow key

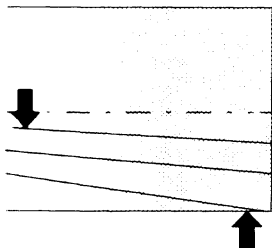
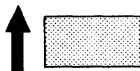

Correct with down arrow key



Bottom Bow Adjustment

The bottom bow function corrects for curvature occurring in the lower part of the image. Use the up and down arrow key to adjust the bottom bow in the lower part of the setup pattern. Adjust until the horizontal lines are straight.

A bar scale and a number indicator (between 0 and 100 %) give a visual indication of the adjustment.

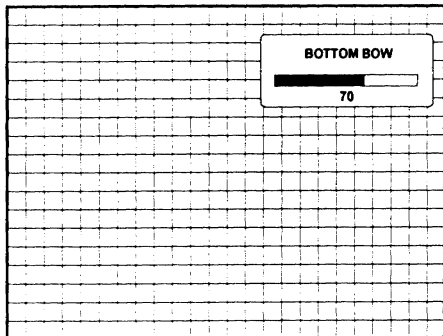

ENTER continues to Size-Linearity
EXIT returns to bottom keystone adjustment

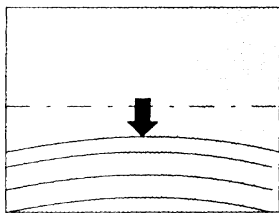

Correct with up
arrow key

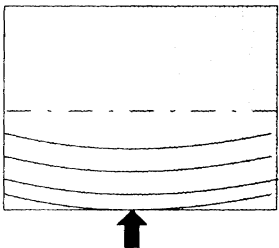

Correct with
down arrow key



Size-linearity Adjustment

Size adjustments affect the height and width of the projected image. The vertical linearity adjustment is used to adjust the horizontal lines of the setup pattern until the spacing between them is even. The horizontal phase adjustment is used to shift the image horizontally across the raster.

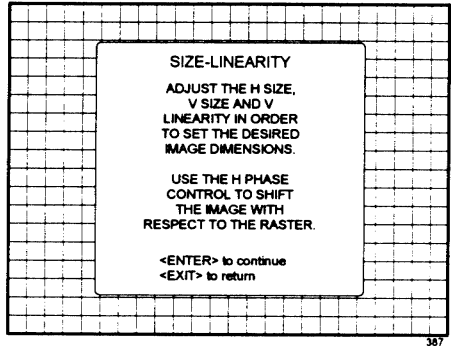

ENTER continues to vertical linearity adjustment
EXIT returns to Top-Bottom adjustments
ADJUST returns to operational mode

Vertical Linearity Adjustment

Adjust the vertical linearity with the arrow keys until the distance between the horizontal lines of the set up pattern are equal.

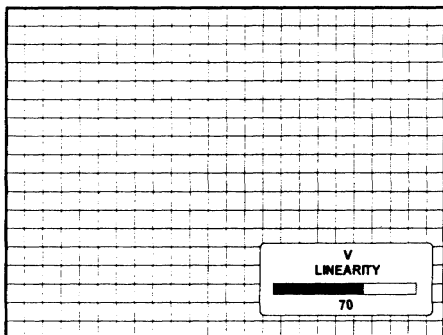

ENTER continues to vertical size adjustment
EXIT returns to the Size-Linearity menu.

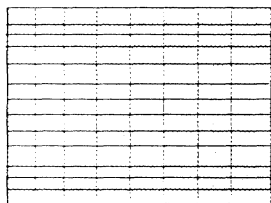

Correct with up
arrow key

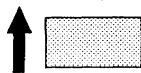

Correct with
down arrow key



Vertical Size Adjustment

Adjust the vertical size with the up or down arrow key until the exact image height is obtained.

Note :

- if the internal # pattern was selected, this pattern remains on the screen.
- if the genlocked pattern was selected, the external source will be displayed.

Hint :

In order to avoid loss of resolution in the projected image and to ensure maximum CRT longevity, do not use an excessively small vertical size setting.

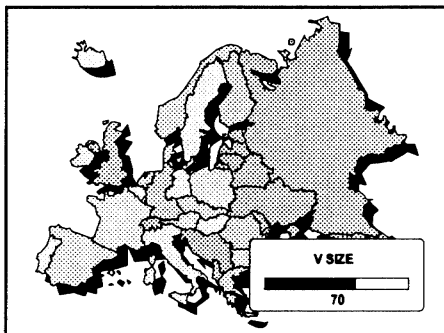

ENTER continues to horizontal phase adjustment

EXIT returns to vertical linearity adjustment

A bar scale and a number indicator (between 0 and 100) give a visual indication of the vertical size adjustment.

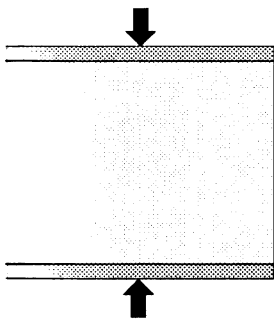

Correct with
down arrow key

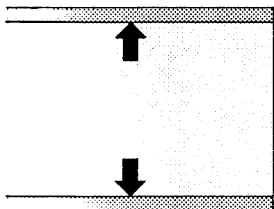
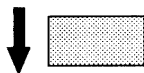

Correct with up
arrow key



Horizontal Phase Adjustment

Note : No horizontal phase adjustment is available on the internal # pattern.

Therefore :

- if the internal # pattern was selected, this pattern remains on the screen.
- if the genlocked pattern was selected, the external source will be displayed.

Adjust the horizontal phase with the arrow keys until the image is centered in the middle of the raster.

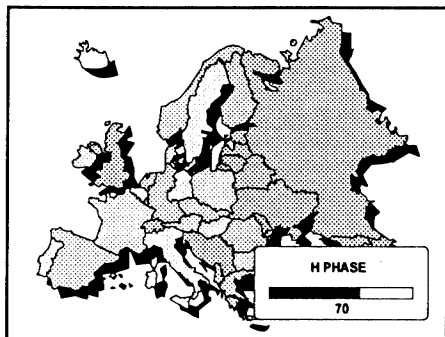

ENTER continues to Convergence
EXIT returns to vertical size adjustment

A bar scale and a number indicator (between 0 and 100) on the screen give a visual indication of the horizontal phase adjustment.

Correct with right
arrow key

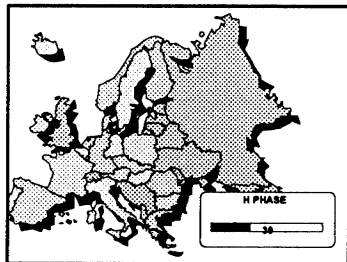

Correct with left
arrow key

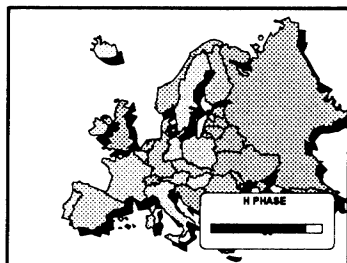
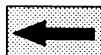

Convergence Adjustment

Convergence adjustments affect both the horizontal and vertical lines of the setup pattern. These adjustments are performed on the red image while superimposed on the green image and then on the blue image while superimposed on the green image.

The screen area is divided into 25 areas. Within each area it is possible to move the horizontal and vertical lines of the red and blue picture until they coincide with the green lines.

Use the arrow keys to make horizontal and vertical convergence adjustments in the area indicated by the box. Pressing **ENTER** will move the box to the next area of the setup pattern to be converged. Pressing **EXIT** will move the box back to the last area.

The 'guided adjustment' program will start with the convergence adjustment of the red picture on the green and continues with the blue image on the green image.

Attention : when green convergence adjustments are available (option). The control software starts with these green corrections (the menu will indicate it also). Adjust until the vertical and horizontal lines are straight.

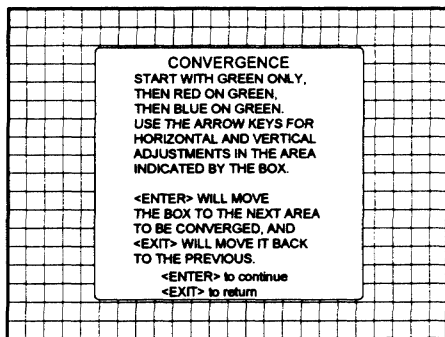

ENTER continues to convergence adjustment
EXIT returns to Size-Linearity adjustments
ADJUST returns to operational mode.

25	23	9	15	17
24	22	8	14	16
5	4	1	2	3
20	18	6	10	12
21	19	7	11	13

397

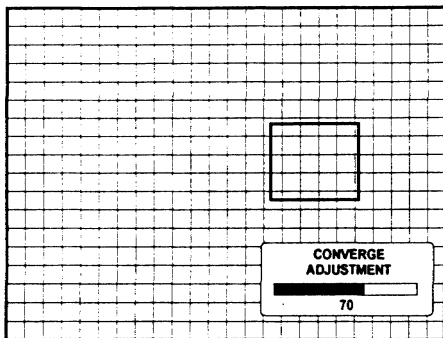
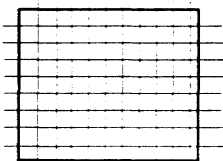
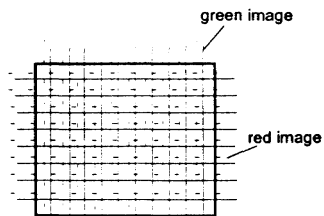

ENTER selects a new box and at the end it continues with the Blanking Adjustment.
EXIT returns to the last area.

Blanking Adjustment

Blanking adjustments affect only the edges of the projected image and are used to frame the projected image on to the screen and to hide or black out unwanted information (or noise). A 0% on the bar scale indicates no blanking.

The following blanking corrections are possible :

- top blanking
- bottom blanking
- left blanking
- right blanking

Note :

- if the internal # pattern was selected, this pattern remains on the screen.
- if the genlocked pattern was selected, the external source will be displayed.

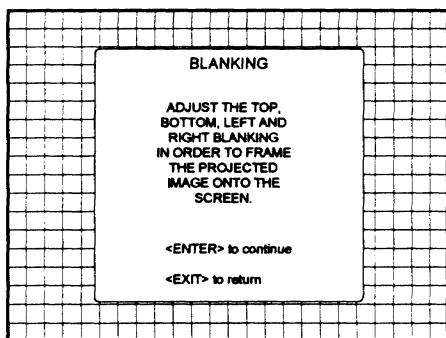

ENTER continues to top blanking adjustment.

EXIT returns to convergence menu

ADJUST returns to operational mode

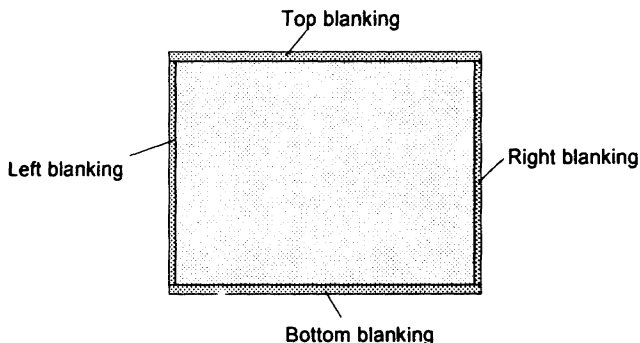

Top blanking adjustment

Use the up or down keys to adjust the top blanking of the setup pattern. Press **ENTER** to continue.

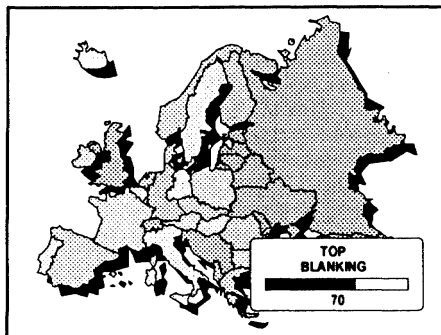

ENTER continues to bottom blanking adjustment.
EXIT returns to blanking adjustments

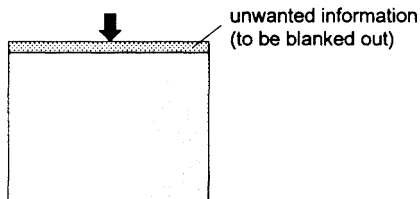

Correct with
down arrow key

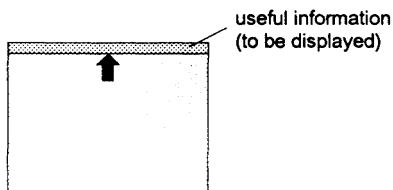

Correct with up
arrow key

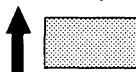

Bottom blanking adjustment

Use the up or down key to adjust the bottom blanking of the setup pattern.

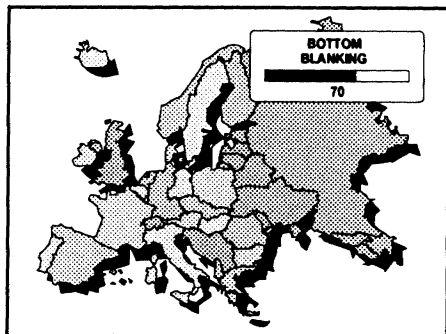

ENTER continues to left blanking adjustment.
EXIT returns to top blanking adjustments.

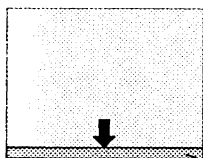

useful information
(to be displayed)

Correct with
down arrow key

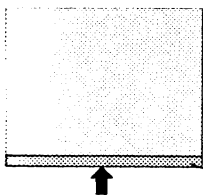

unwanted information
(to be blanked out)

Correct with
up arrow key

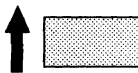

Left blanking adjustment

Use the left or right arrow key to adjust the left blanking of the setup pattern.

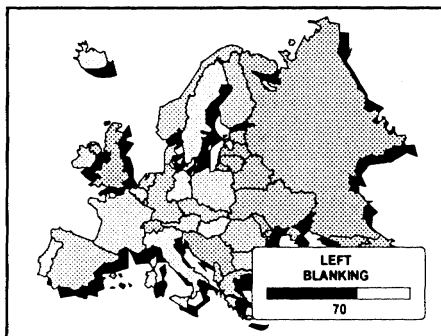

ENTER continues to right blanking adjustment.

EXIT returns to bottom blanking adjustments.

unwanted information
(to be blanked out)

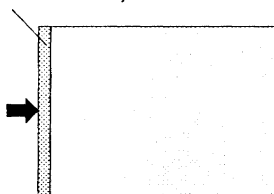

Correct with right
arrow key

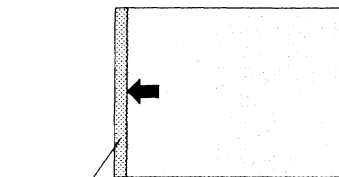

useful information
(to be displayed)

Correct with left
arrow key



Right blanking adjustment

Use the left or right arrow keys to adjust the right blanking of the setup pattern.

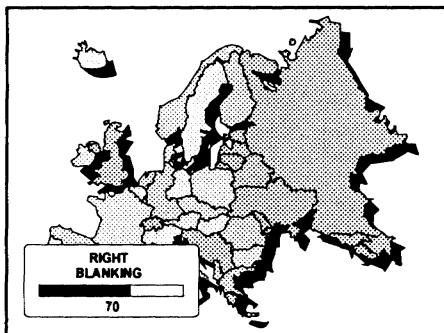

ENTER continues to the White Balance menu.
EXIT returns to left blanking adjustments.

unwanted information
(to be blanked out)

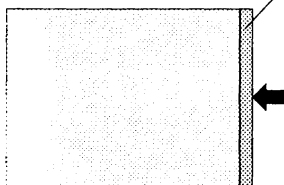

Correct with left
arrow key

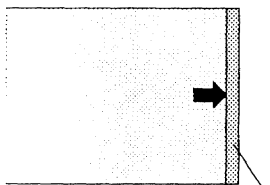

Correct with right
arrow key



useful information
(to be displayed)

White balance

The White Balance function is used to select or adjust the color temperature of white used by the projector.

Use the arrow keys to select a white balance (color temperature) and press **ENTER** to continue.

The table below lists the possible choices :

3200 K
6500 K
9300 K
CUSTOM

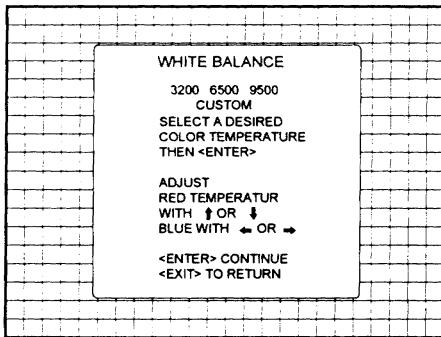

ENTER continues with the Black Balance or displays the gain adjustment menu.
EXIT returns to Right blanking adjustment.

When **CUSTOM** is selected, the gain for Red and Blue can be adjusted with the arrow keys until the desired white balance is obtained.

Use the left and right arrow keys to adjust the Blue gain. Use the up and down arrow keys to adjust the Red gain.

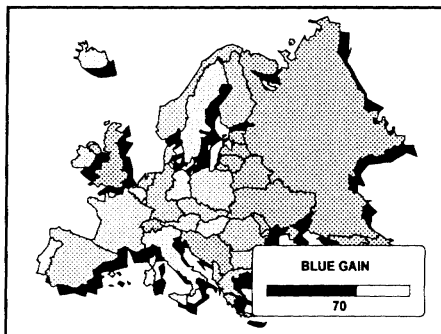

Black balance

Use the up and down arrow keys to adjust the Red cut off and the left and right arrow keys to adjust the Blue cut off. Both adjustments give the correct color temperature setting for low intensity.

A bar scale and a number indicator on the screen give a visual indication of the cut off adjustment.

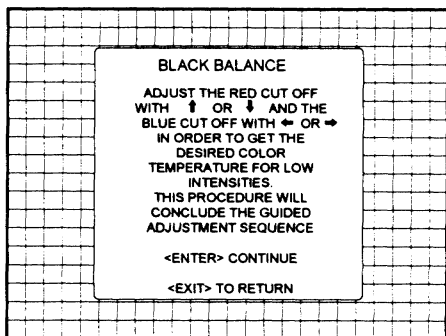

ENTER continues with the cut off adjustment.

EXIT returns to the white balance menu.

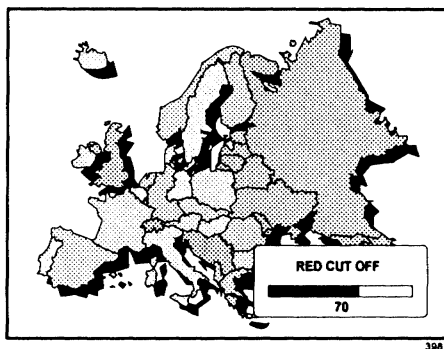

ENTER terminates the Guided Adjustment mode and returns to the Path selection menu.
EXIT returns to the Black balance menu.

RANDOM ACCESS ADJUSTMENT MODE

Starting up the random access adjustment mode

Overview flow chart 'Random Access adjustment mode'

Selecting Setup Pattern

Internal cross hatch pattern

Sync Fast/Slow

Enhanced Blue On/Off Adjustment

Focusing

Color select

Color balance

White balance

Black balance

Geometry adjustments

Horizontal phase

Raster shift adjustment

Left-right adjustments

Top-Bottom adjustments

Horizontal size

Vertical size

Vertical linearity

Blanking adjustments

Convergence adjustments

Starting up the random access adjustment mode.

Use the arrow keys to highlight "RANDOM ACCESS" and then press ENTER.

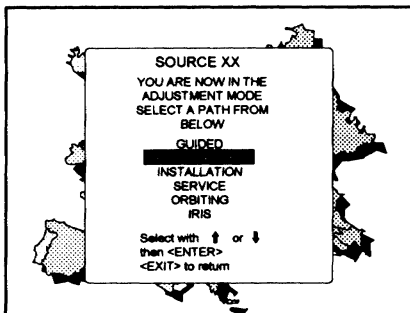

ENTER continues to Setup Pattern Selection
EXIT returns to operational mode

Overview flowchart 'Random Access Adjustment' mode

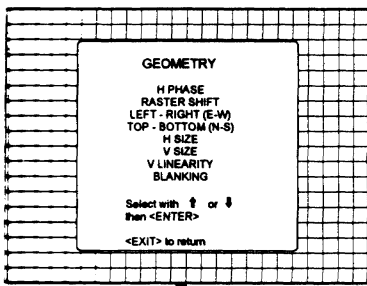
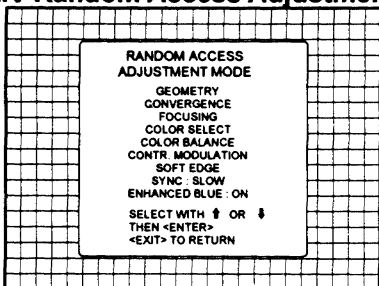

Continue on next page

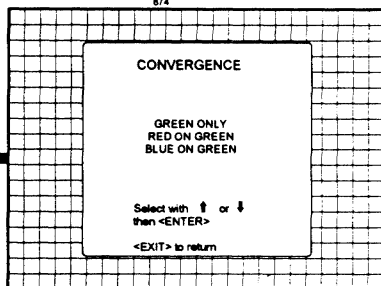

Continue on next page

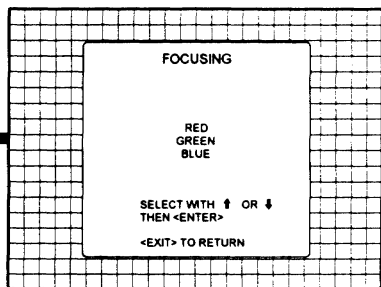
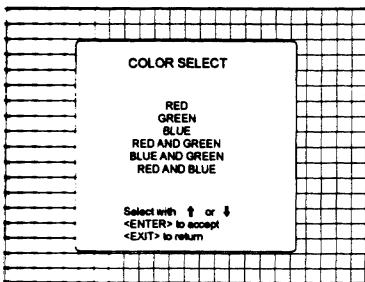

Continue on next page

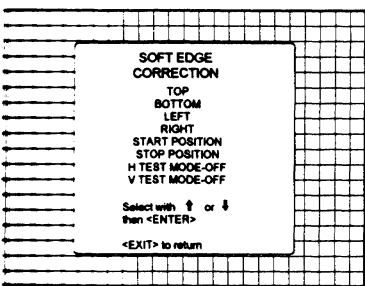

Option

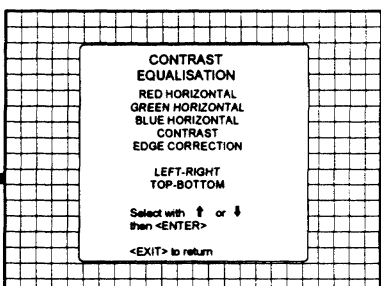

Option

RANDOM ACCESS ADJUSTMENT MODE

GEOMETRY

H PHASE
 RASTER SHIFT
 LEFT - RIGHT (E-W)
 TOP - BOTTOM (N-S)
 H SIZE
 V SIZE
 V LINEARITY
 BLANKING

Select with ↑ or ↓
 then <ENTER>

<EXIT> to return

401

LEFT-RIGHT

V CENTERLINE BOW
 V CENTERLINE SKEW
 SIDE BOW
 SIDE KEYSTONE

Select with ↑ or ↓
 then <ENTER>

<EXIT> to return

402

TOP - BOTTOM

H CENTERLINE BOW
 H CENTERLINE SKEW
 TOP KEYSTONE
 TOP BOW
 BOTTOM KEYSTONE
 BOTTOM BOW

Select with ↑ or ↓
 then <ENTER>

<EXIT> to return

403

BLANKING

TOP
 BOTTOM
 LEFT
 RIGHT

Select with ↑ or ↓
 then <ENTER>

<EXIT> to return

CONVERGENCE

GREEN ONLY
 RED ON GREEN
 BLUE ON GREEN

Select with ↑ or ↓
 then <ENTER>

<EXIT> to return

CONVERGENCE

SEL select area
 using
 arrow keys
 ADJ adjust area
 using
 arrow keys

Toggle between
 SEL and ADJ
 with <ENTER>

<ENTER> continue

<EXIT> to return

Selecting Setup Pattern

If an external source is connected to the projector, Setup pattern menu will be displayed. Use the arrow keys to highlight the desired setup pattern and then press **ENTER**.

Genlocked pattern : internally generated cross hatch pattern, locked on the external source.

Internal # pattern : internally generated cross hatch pattern and locked on internal generated sync signals. (No external source necessary)

If no external source is connected to the projector, the internal cross hatch pattern menu will be displayed.

The menus in this manual are created for an external source, connected to one of the inputs, and the 'Genlocked pattern' is selected.

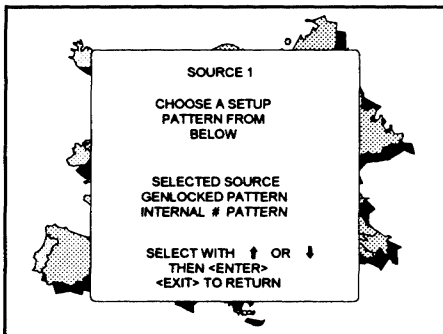

391

ENTER continues to Random Access Adjustment Mode or Internal # Pattern Selection
EXIT returns to Path Selection
ADJUST returns to operational mode

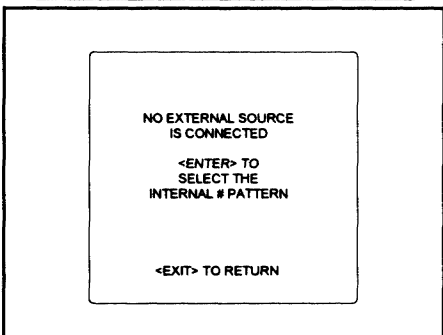

392

ENTER displays the internal # pattern mnu
EXIT returns to the Path Selection menu.

Internal Cross Hatch Pattern

The Internal # pattern menu will be displayed if the internal cross hatch pattern has been selected or if no source is connected to the projector.

The table below lists the 8 factory preset frequencies available.

Use the arrow keys to highlight the desired cross hatch frequency and then press **ENTER**.

STD : Fh = 15.6 kHz	Fv = 50 Hz
CGA : Fv = 15.7 kHz	Fv = 60 Hz
EGA : Fv = 21.9 kHz	Fv = 60 Hz
VGA : Fv = 31.5 kHz	Fv = 60 Hz
PR1 : Fv = 48.0 kHz	Fv = 60 Hz
PR2 : Fv = 64.0 kHz	Fv = 70 Hz
PR3 : Fv = 90.0 kHz	Fv = 50 Hz
PR4 : Fv = 128.0 kHz	Fv = 60 Hz

It is possible to store user defined cross hatch frequencies in PR1 - PR4. Handle as follows to program a custom cross hatch frequency.

- highlight the desired storage location (PR1-PR4) on the Internal # pattern menu.
- Press **TEXT** to reprogram.
- Use the arrow keys to select the digits to be changed.
- Reprogram the desired horizontal frequency as xx.x kHz and the vertical frequency as xxx Hz using the numeric keys.
- Press **ENTER** to confirm.

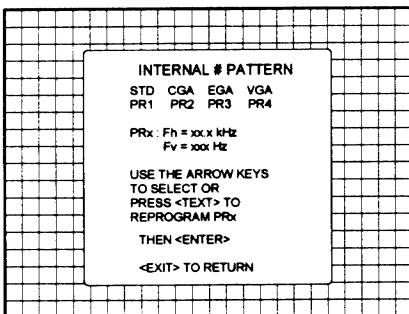

383

ENTER continues to the Random Access Adjustment Mode.
EXIT returns to the Setup Pattern Selection menu.
TEXT gives the reprogram menu

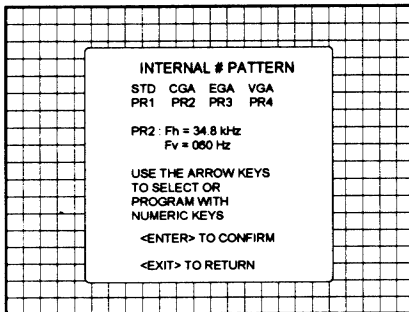

384

ENTER confirms your entry and continues to Random Access Adjustment mode menu.
EXIT returns to Setup Pattern Selection menu.

Example : Desired cross hatch frequency :

Fv = 34.8 kHz

Fv = 60 Hz

Use the arrow keys to highlight the desired storage location (PR1-PR4) and press **TEXT**. The program menu appears on the screen. Use the arrow keys to go to the first digit of the horizontal frequency and press.

3 4 8 0 6 0 <ENTER>

Note : enter always 6 digits

In the example, an 0 is added between the last significant digit of the hor. freq. and the first significant digit of the vert. freq. to complete the 6 digits.

Random access adjustment mode selection menu.

This is the main menu for the Random Access adjustment mode.

Through this menu, the following adjustments and features are accessible :

- Enhanced blue (only for RGB)
- Sync slow/fast
- Focusing
- Color balance
- Geometry
- Convergence
- Color select
- Contrast modulation (option)
- Soft edge (option)

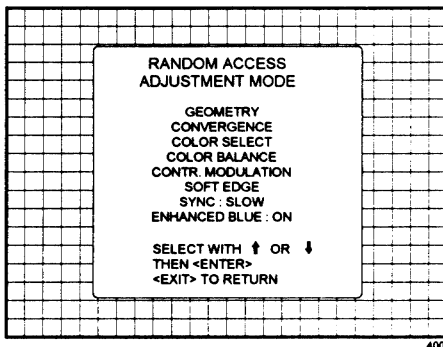

Sync Fast/Slow Adjustment

The sync functions is used to minimize horizontal jittering or tearing at the top of the displayed image.

Highlight **SYNC** with the arrow keys and press **ENTER** to toggle between **FAST** and **SLOW**.

Note: SYNC is normally used in the SLOW position. The FAST position is used to compensate for unsteady sync pulses from older video playback equipment.

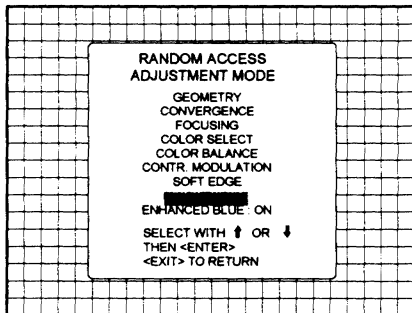

674h

ENTER will toggle Sync between **FAST** and **SLOW**
EXIT will return to Setup Pattern Selection

Enhanced Blue On/Off Adjustment

Highlight **ENHANCED BLUE** with the arrow keys and press **ENTER** to toggle between **ON** and **OFF**. (only available when RGB signals are connected) When 'Enhanced Blue' is **ON**, the blue color will be displayed as cyan.

Note: Enhanced blue is only used when an RGBS or RGSB analog signal from a computer is being displayed. Enhanced blue is not recommended for non computer generated images.

For displaying graphics, this 'Enhanced Blue' function could falsify the color reproduction. In this case, put Enhanced Blue **OFF**.

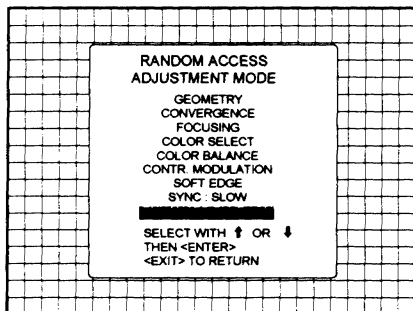

674h

ENTER will toggle Enhanced Blue between **ON** and **OFF**
EXIT will return to the Random access main menu.
ADJUST returns to operational mode

Focusing

Before starting the 'focusing' adjustment, be sure the lenses are correctly focused.

Use the arrow keys to select 'Focusing' and press ENTER.

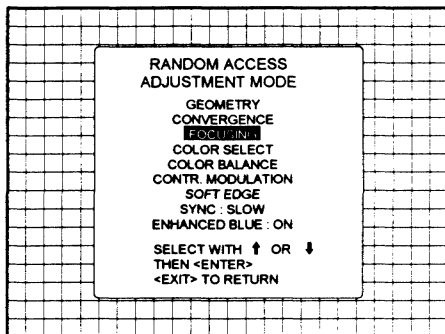

874c

ENTER continues to the Focusing color select menu.

EXIT returns to Internal Crosshatch Selection or Setup Pattern Selection menu.

ADJUST returns to operational mode.

Focusing color select.

The focusing has to be done for the three colors separately. Therefore, start by selecting Green with the arrow keys and adjust Midpoint, top, bottom, left and right focusing.

Return to this focusing color select menu and continue with Red and Blue. Repeat for both colors Midpoint, top, bottom, left and right focusing.

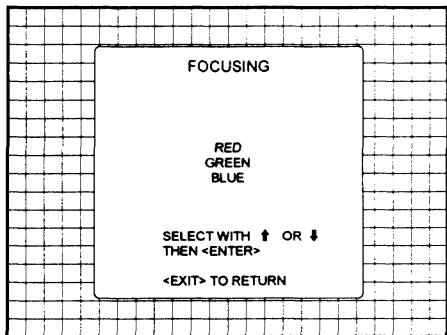

872

ENTER selects the Focusing menu for the selected color.

EXIT returns to the Random access main menu.

Midpoint focusing

Use the arrow keys to select *midpoint* and press **ENTER**.

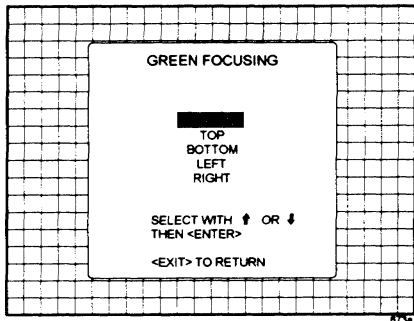

ENTER continues with the midpoint focusing for the selected color.

EXIT returns to the focusing color select menu.

Adjust with the left and right arrow keys until the center of the image is sharp.

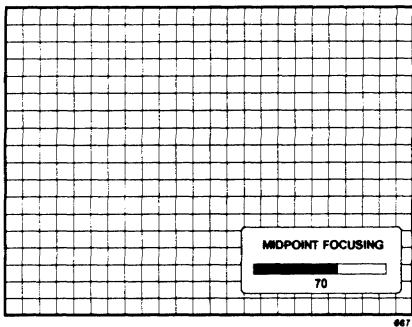

Press **ENTER** to return to the focusing menu.

Top image focusing

Use the arrow keys to select *top* and press **ENTER**.

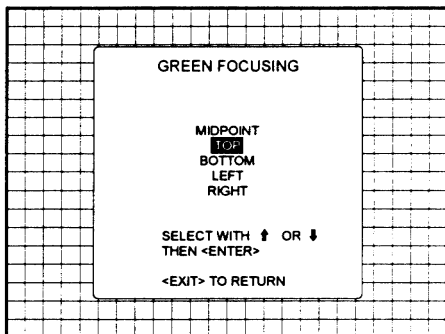

873b

ENTER selects the top focusing.
EXIT returns to the Focusing color select menu.

Use the left and right arrow keys to adjust the top focusing. Adjust until the upper part of the image is sharp.

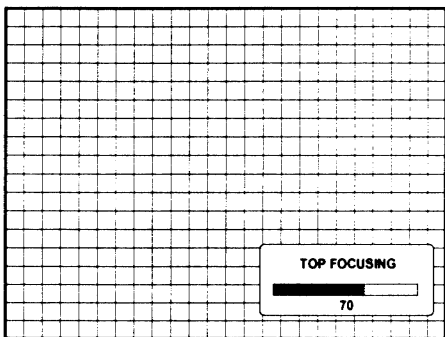

868

Bottom image focusing

Use the arrow keys to select *Bottom* and press **ENTER**.

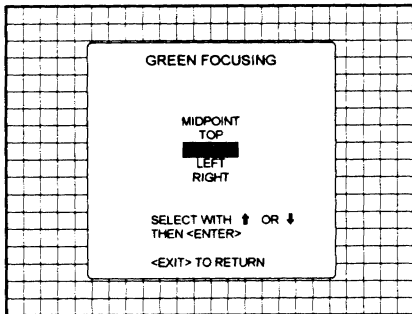

ENTER selects the bottom focusing.
EXIT returns to the Focusing color select menu.

Use the left and right arrow keys to adjust the bottom focusing. Adjust until the lower part of the image is sharp.

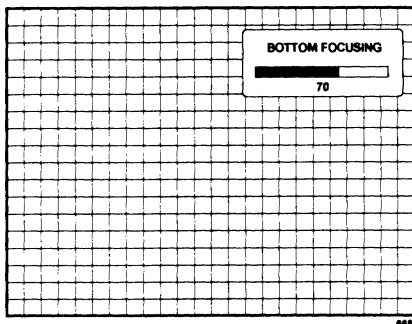

ENTER returns to the focusing menu

Left image focusing

Use the arrow keys to select *Left* and press **ENTER**.

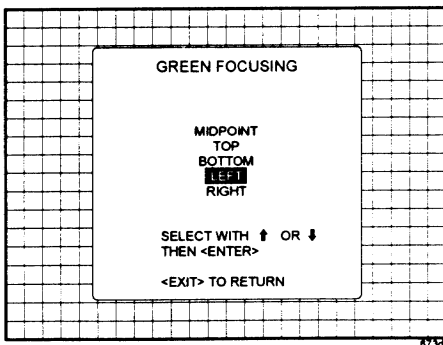

ENTER selects the left focusing.
EXIT returns to the Focusing color select menu.

Use the left and right arrow keys to adjust the left focusing. Adjust until the left part of the image is sharp.

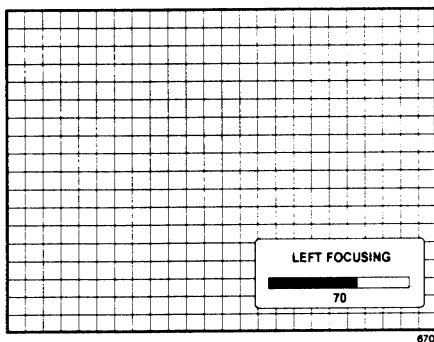

ENTER returns to the focusing menu

Right image focusing

Use the arrow keys to select *Left* and press **ENTER**.

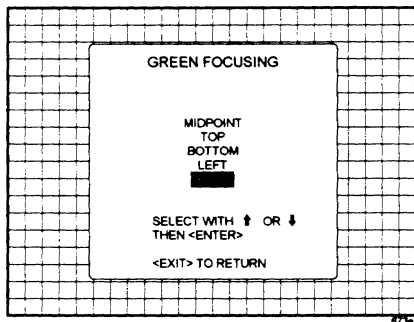

ENTER selects the right focusing.
EXIT returns to the Focusing color select menu.

Use the left and right arrow keys to adjust the left focusing. Adjust until the left part of the image is sharp.

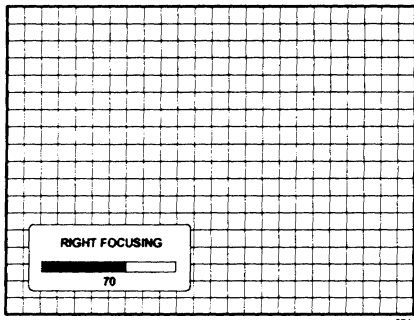

ENTER returns to the focusing menu

Color Select

Highlight *COLORSELECT* with the arrow keys and press **ENTER** to display the color select menu.

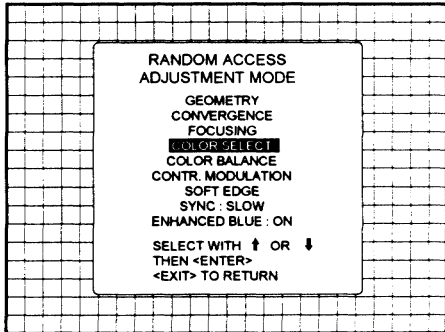

ENTER continues to the color select menu
EXIT will return to Internal Crosshatch Selection or Setup Pattern Selection Menu
ADJUST returns to operational mode

Use the arrow keys to highlight a color (CRT) or combination of colors to display the projected image in that specific color.

To select a new color, press **ENTER**, the color selection menu appears again on the screen. To terminate the color select procedure, press **EXIT**.

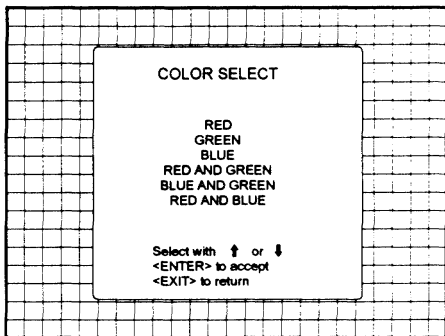

ENTER continues with the selected color or color combination.
EXIT returns to the Random access mode selection menu.

Color balance

Highlights Color balance with the arrow keys and press **ENTER** to display the *Color balance* menu. Within the Color balance menu, it is possible to adjust the White balance and the black balance.

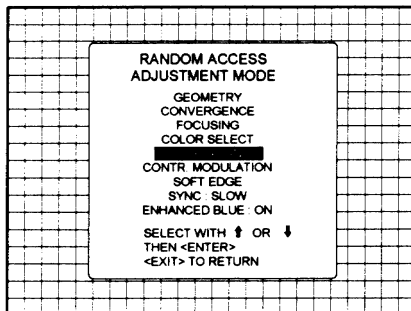

574a

ENTER continues with the Color balance menu.

EXIT returns to Internal Crosshatch Selection menu or Setup Pattern Selection menu.

ADJUST returns to operational mode.

White balance

The White Balance function is used to select or adjust the color temperature of white used by the projector.

Use the arrow keys to select a desired color temperature or to select Custom. Custom is an adjustable color temperature. The following choices are possible :

3200 K
6500 K
9300 K
CUSTOM

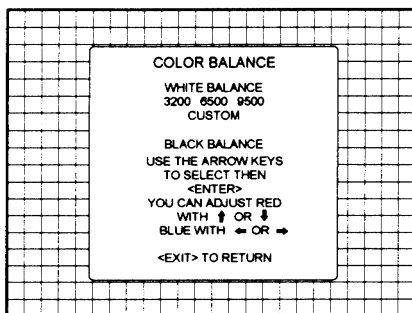

204

When Custom is selected, the gain for Red and Blue can be adjusted with the arrow keys until the desired white balance is obtained.

Use the up and down arrow keys to adjust the Red gain and the left and right arrow keys to adjust the Blue gain. When the desired white balance is obtained, press **ENTER** to continue and to display the color balance menu again.

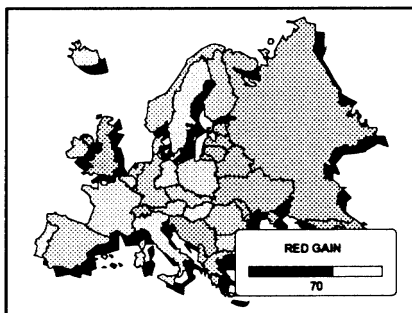

Black balance

Use the arrow keys to highlight Black Balance and press ENTER. The cut off for red and blue can be adjusted until the desired black balance is obtained.

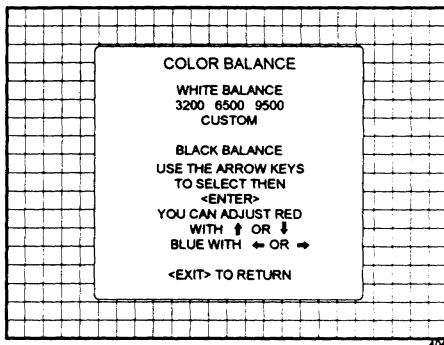

ENTER continues with the cut off adjustment.
EXIT returns to the Random Access mode selection menu.

Adjust the Red cut off with the up and down arrow keys and adjust the blue cut off with the left and right arrow keys. A bar scale indicates the amount of adjustment.

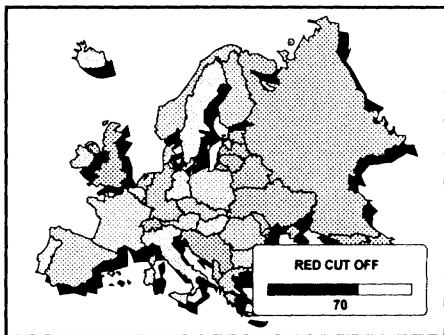

Geometry Adjustments

The geometry adjustments have to be done only on the green image. These adjustments are automatically implemented for the other color images : Left-right (EW) and Top-Bottom corrections, blanking, Horizontal amplitude, vertical amplitude, vertical linearity and Horizontal phase.

Highlight *GEOMETRY* with the arrow keys and press **ENTER** to display the geometry menu.

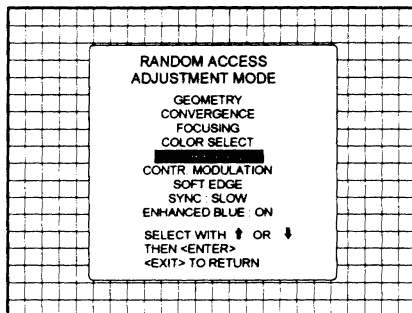

ENTER will display Geometry menu
EXIT will return to Internal Crosshatch Selection or Setup Pattern Selection Menu
ADJUST returns to operational mode

Within the geometry adjust menu, the following adjustments are available :

- horizontal phase (not for internal # pattern).
- raster shift
- left-right corrections
- top-bottom corrections
- horizontal size
- vertical size
- vertical linearity
- blanking

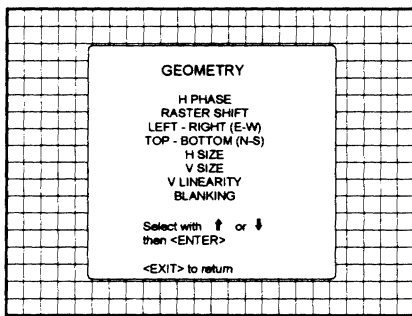

ENTER will display the selected option
EXIT will return to Random Access Adjustment Mode main menu
ADJUST returns to operational mode

The convergence corrections are disabled during geometry corrections. The blanking corrections are only enabled during the blanking adjustments.

Horizontal Phase Adjustment

Use the arrow keys to highlight
H PHASE on *Geometry* menu
and then press **ENTER**.

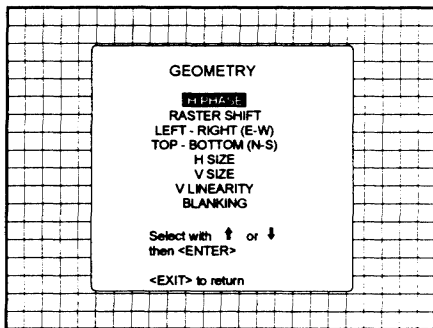

401a

ENTER will select the horizontal phase adjustment.

EXIT returns to the Random access adjustment main menu.

ADJUST returns to operational mode.

Note : No horizontal phase adjustment is available on the internal # pattern.

Therefore :

- if the internal # pattern was selected, this pattern remains on the screen.
- if the genlocked pattern was selected, the external source will be displayed.

Adjust the horizontal phase with the arrow keys until the image is centered in the middle of the raster.

Hint : to check if the hor phase of the image is correctly aligned, switch back to the geometry menu. This text box is always centered in the middle of the raster.

A bar scale and a number indicator (between 0 and 100) on the screen give a visual indication of the horizontal phase adjustment.

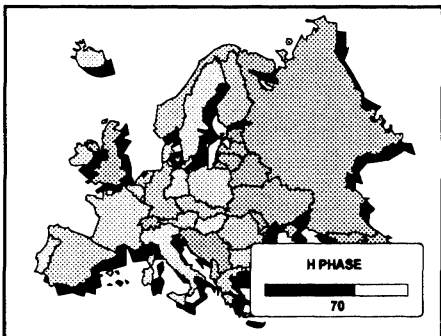

395

ENTER continues to geometry menu .

Correct with right
arrow key

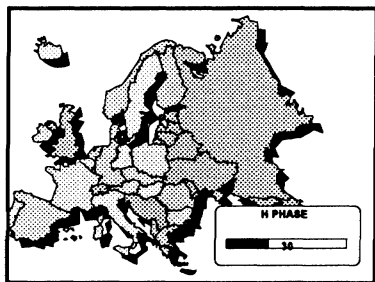

Correct with left
arrow key

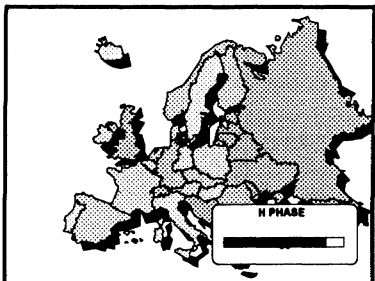

396

Raster Shift Adjustment

The green raster must be centered both horizontally and vertically on the center of the CRT surface. To center the green raster, look into the green lens and use the arrow keys to move the raster.

CAUTION

It is necessary to look into the lenses to perform these adjustments. To avoid eye discomfort while looking into the lenses, reduce the contrast and gradually increase the brightness level until the raster becomes visible on the face of the CRT.

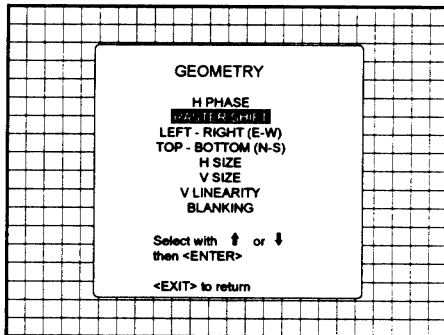

ENTER will select green raster shift adjustment
EXIT returns to random access adjustment mode menu.

Warning : In order to ensure maximum CRT longevity and to avoid CRT damage, do not shift the raster outside the phosphor area of the CRT.

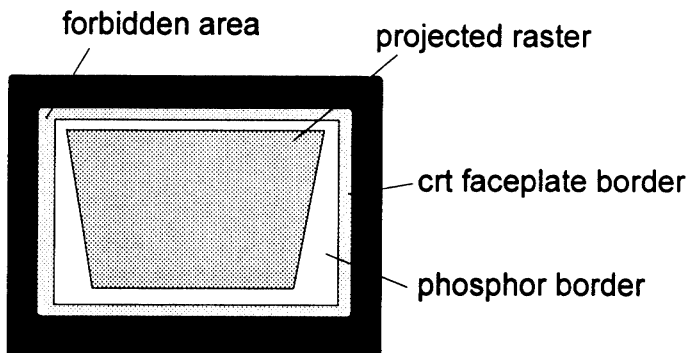

To start the adjustment, use the arrow keys to highlight Raster shift and press ENTER to display the green raster on the phosphor.

RANDOM ACCESS ADJUSTMENT MODE

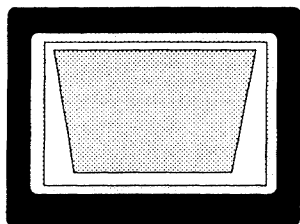

correct raster position

wrong raster position

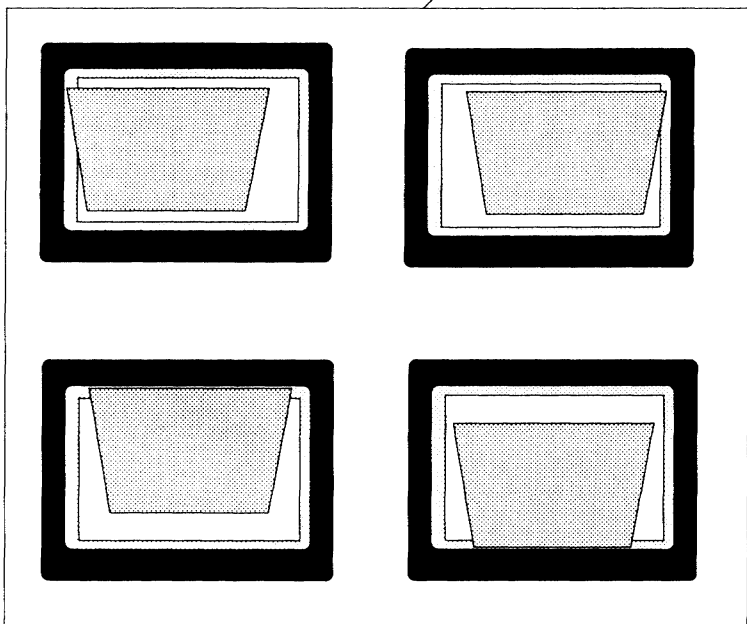

After centering the green raster, continue with red and blue.
Press EXIT to return to the Geometry menu.

Left-Right (east-west) Adjustments

Left-right adjustments affect only the vertical lines of the projected image. Only the green image is displayed while making left-right adjustments. The red and blue images will automatically be corrected in the same manner. Convergence corrections are automatically disabled for the duration of these adjustments.

The following adjustments can be executed

- vertical centerline bow
- vertical centerline skew
- side keystone (left - right)
- side bow (left - right)

Use the arrow keys to highlight **LEFT-RIGHT (EW)** on the geometry menu and then press **ENTER**.

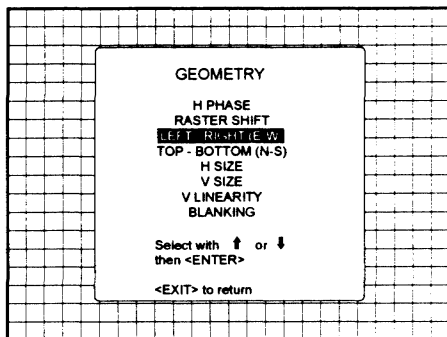

ENTER will select Left-Right adjustment menu

EXIT returns to random access adjustment mode main menu.

ADJUST returns to operational mode

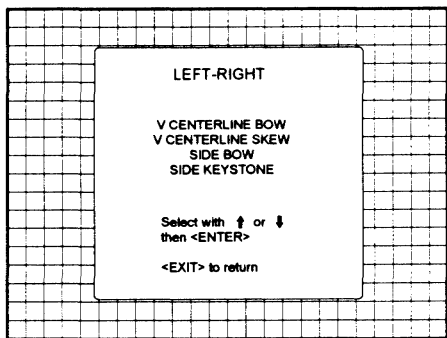

Vertical Centerline Bow Adjustment

The Vertical Centerline Bow function corrects for curvature in the horizontal direction in the middle of the picture for the vertical lines. Use the arrow keys to highlight *V CENTERLINE BOW* on the Left-Right menu and then press **ENTER**.

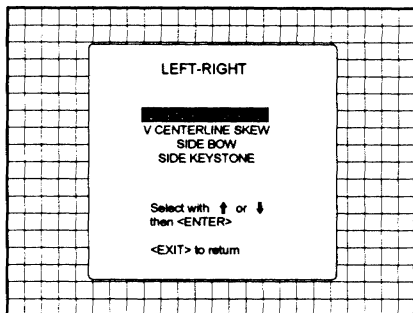

402a

ENTER will select vertical centerline bow adjustment
EXIT will return to Geometry menu
ADJUST returns to operational mode

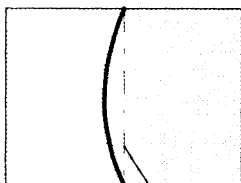
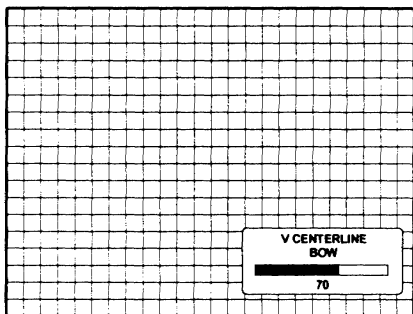

Vertical centerline

Correct with right
arrow key

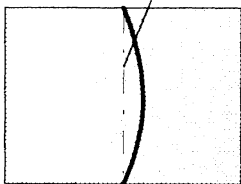

Correct with left
arrow key



ENTER will return to Left-Right
adjustment menu
EXIT will return to Geometry
menu

Vertical Centerline Skew Adjustment

The vertical centerline skew function corrects for tilting of the displayed image. Use the arrow keys to highlight **V CENTERLINE SKEW** on the geometry menu and then press **ENTER**

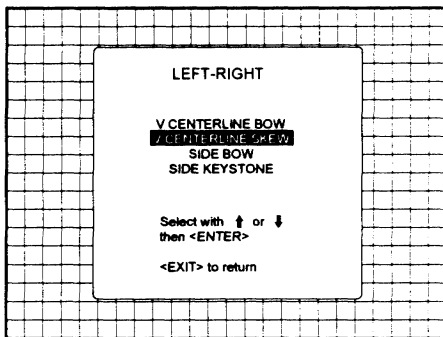

ENTER will select vertical centerline skew adjustment
EXIT will return to Geometry menu
ADJUST returns to operational mode

Adjust with the left and right arrow keys until the vertical centerline is straight. Misalignment of the outer vertical lines will be corrected with the bow and keystone corrections. Press **ENTER** to continue.

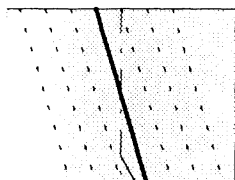
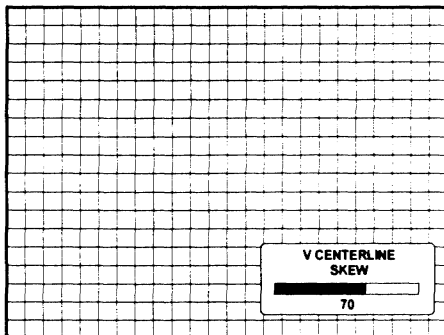

Correct with right arrow key



Vertical centerline

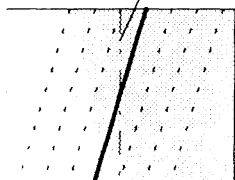

Correct with left arrow key

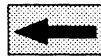

ENTER will return to Left-Right adjustment menu
EXIT will return to Geometry menu

Side Bow Adjustment

The side bow adjustment corrects for curvature occurring at the sides of the displayed image and that for the vertical lines.

Use the arrow keys to highlight *SIDE BOW* on the Geometry menu and then press **ENTER**.

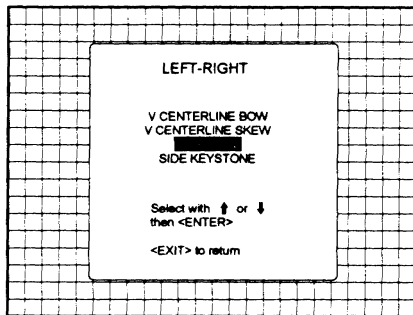

402c

ENTER will select side bow adjustment
EXIT will return to Geometry menu
ADJUST returns to operational mode

Use the left or right arrow key to adjust the side bow of the setup pattern (vertical lines) and press **ENTER** to continue.

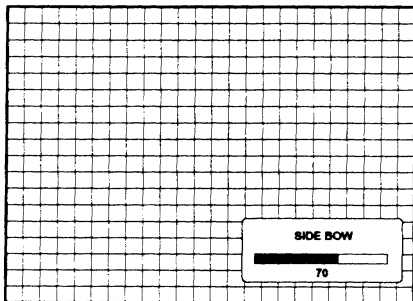

405

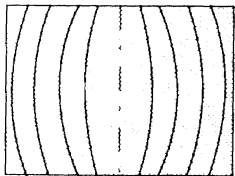

Correct with right
 arrow key

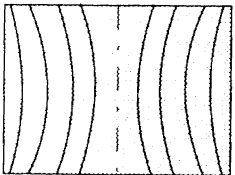
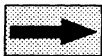

Correct with left
 arrow key

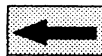

ENTER will return to Left-
 Right adjustment menu
EXIT will return to Geom-
 etry menu

Side Keystone Adjustment

The side keystone adjustment corrects the keystone geometry distortion of the vertical lines on the sides of the image.

Use the arrow keys to highlight *SIDE KEYSTONE* on Left-Right menu and then press **ENTER**.

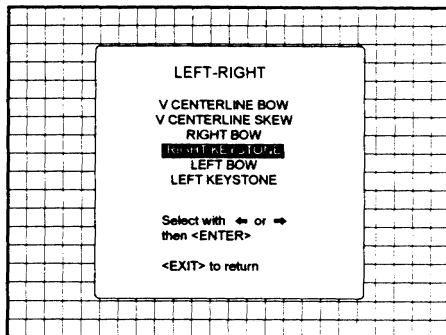

ENTER will select side keystone adjustment
EXIT will return to Geometry menu.
ADJUST returns to operational mode

Use the left or right arrow key to adjust the side keystone (vertical lines) of the setup pattern and press **ENTER** to continue.

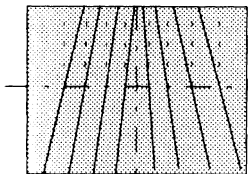
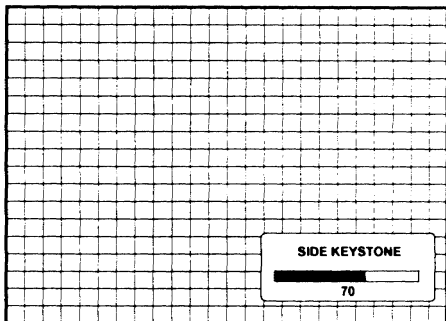

Correct with right arrow key

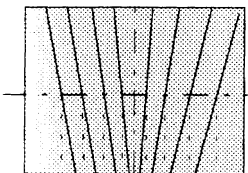

Correct with left arrow key

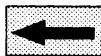

ENTER will return to Left-Right adjustment menu
EXIT will return to Geometry menu

Top-Bottom (north-south) Adjustments

Top-Bottom adjustments affect only the horizontal lines of the projected image. Convergence corrections are automatically disabled for the duration of these adjustments.

Use the arrow keys to highlight *TOP-BOTTOM (N/S)* on the geometry menu and then press **ENTER**.

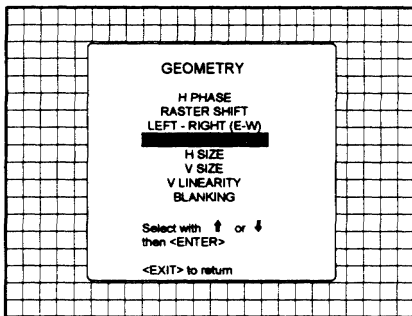

ENTER will select Top-Bottom adjustment menu
EXIT returns to random access adjustment mode menu.
ADJUST returns to operational mode

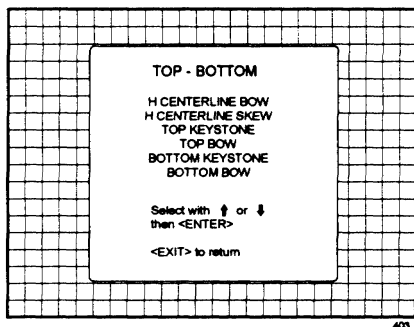

EXIT will return to Geometry

Horizontal Centerline Bow Adjustment

The Horizontal Centerline Bow function corrects for curvature in the vertical direction in the middle of the picture and that for the horizontal lines

Use the arrow keys to highlight **H CENTERLINE BOW** on the **TOP-BOTTOM** menu and then press **ENTER**.

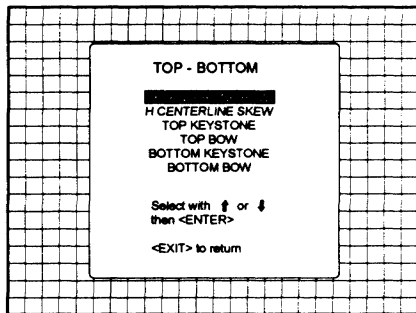

ENTER will select horizontal centerline bow adjustment
EXIT will return to Geometry menu
ADJUST returns to operational mode

Use the up and down arrow keys to adjust the horizontal centerline bow of the setup pattern. A bar scale and a number indicator will give a visual indication of the bow correction.

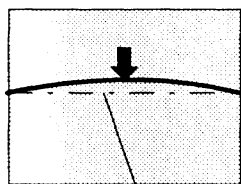
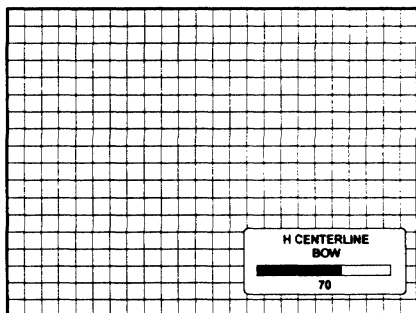

Hor. centerline

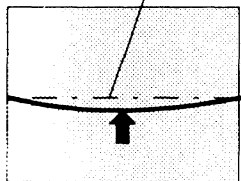

Correct with
down arrow key



Correct with up
arrow key



ENTER will return to Top-Bottom adjustment menu
EXIT will return to Geometry menu

Horizontal Centerline Skew Adjustment

The horizontal centerline skew function corrects for tilting of the horizontal lines in the middle of the image.

Use the arrow keys to highlight *H CENTERLINE SKEW* on the TOP-BOTTOM menu and then press **ENTER**.

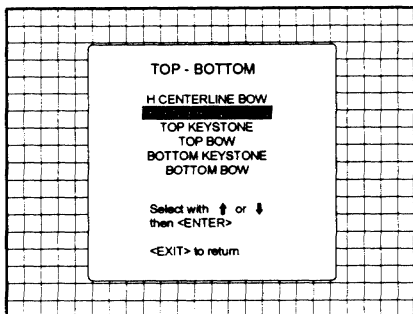

403b

ENTER will select horizontal centerline skew adjustment
EXIT will return to Geometry menu
ADJUST returns to operational mode

Use the up and down arrow keys to adjust the horizontal centerline skew of the setup pattern.

A bar scale and a number indicator will give a visual indication of the skew correction.

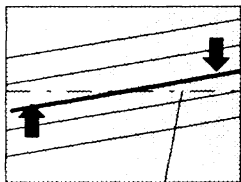
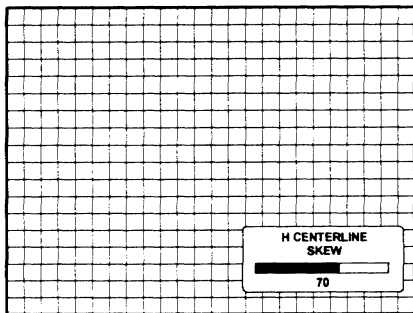

Hor. centerline

Correct with
down arrow key

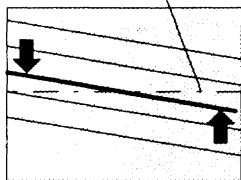
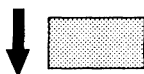

Correct with up
arrow key

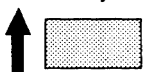

ENTER will return to Top-Bottom adjustment menu
EXIT will return to Geometry menu

Top Keystone Adjustment

The top keystone function corrects for keystone geometry distortion of the horizontal lines in the upper part of the image.

Use the arrow keys to highlight **TOP KEYSTONE** on the **TOP-BOTTOM** menu and then press **ENTER**.

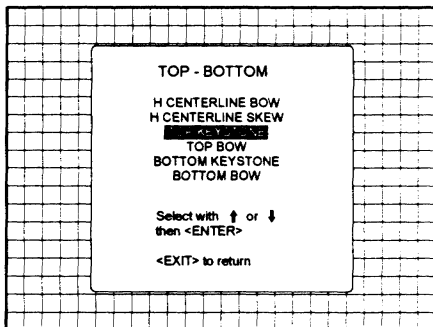

403c

ENTER will select top keystone adjustment
EXIT will return to Geometry menu
ADJUST returns to operational mode

Adjust the horizontal lines in the upper part of the picture with the arrow keys until these lines are straight. Press **ENTER** to continue.

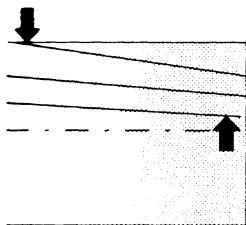
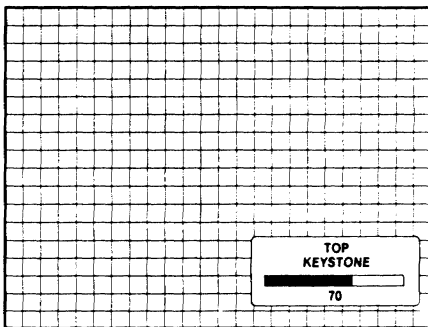

Correct with down arrow key

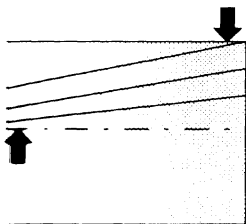
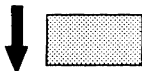

Correct with up arrow key



ENTER will return to Top-Bottom adjustment menu
EXIT will return to Geometry menu

Top Bow Adjustment

The top bow function corrects for curvature occurring in the upper part of the image. Use the arrow keys to highlight **TOP BOW** on the TOP-BOTTOM menu and then press **ENTER**.

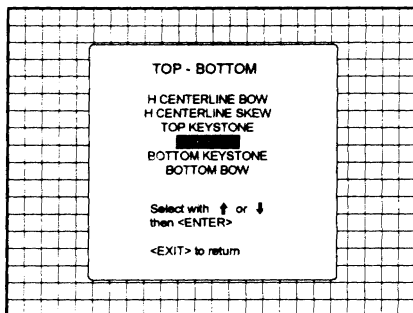

ENTER will select top bow adjustment
EXIT will return to Geometry menu
ADJUST returns to operational mode

Adjust the bow of the horizontal lines in the upper side of the image with the arrow keys until these lines are straight. A bar scale and a number indicator indicate the amount of adjustment.

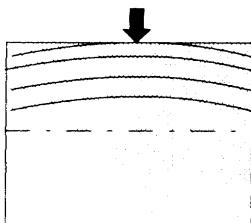
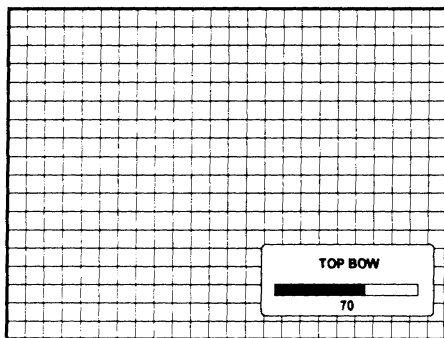

Correct with
down arrow key

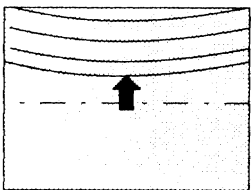

Correct with up
arrow key

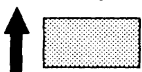

ENTER will return to Top-Bottom adjustment menu
EXIT will return to Geometry menu

Bottom Keystone Adjustment

The bottom keystone function corrects for keystone geometry distortion of the horizontal lines in the lower part of the image.

Use the arrow keys to highlight **BOTTOM KEYSTONE** on the TOP-BOTTOM menu and then press **ENTER**.

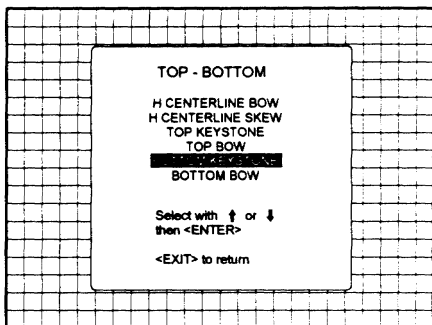

403e

ENTER will select bottom keystone adjustment
EXIT will return to Geometry menu
ADJUST returns to operational mode

Adjust the horizontal lines in the lower part of the picture with the arrow keys until these lines are straight. Press **ENTER** to continue.

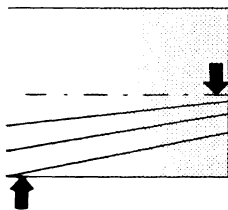
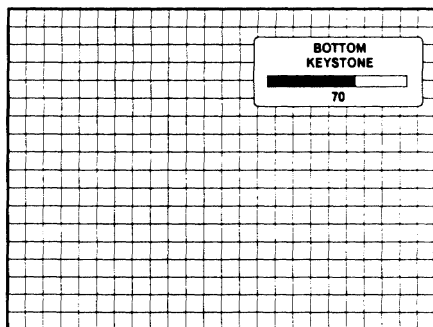

Correct with
down arrow key

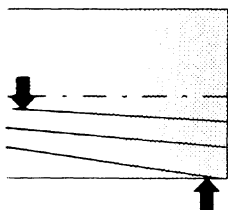

Correct with up
arrow key



ENTER will return to Top-Bottom adjustment menu
EXIT will return to Geometry menu
menu

Bottom Bow Adjustment

The bottom bow function corrects for curvature occurring in the lower part of the image.

Use the arrow keys to highlight **BOTTOM BOW** on the TOP-BOTTOM menu and then press **ENTER**.

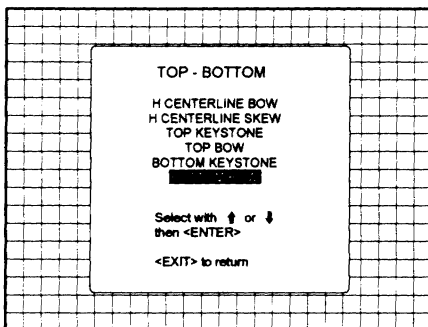

4031

ENTER will select bottom bow adjustment
EXIT will return to Geometry menu
ADJUST returns to operational mode

Use the up and down arrow key to adjust the bottom bow in the lower part of the setup pattern. Adjust until the horizontal lines are straight. A bar scale and a number indicator give a visual indication of the adjustment.

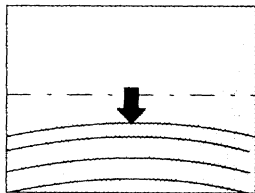
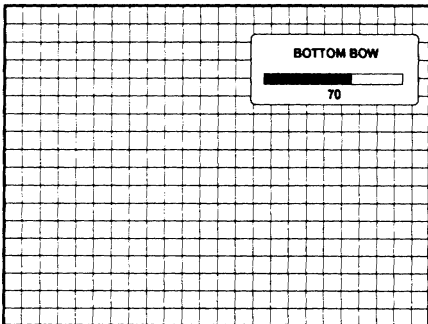

Correct with
down arrow key

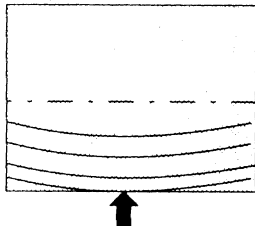

Correct with up
arrow key



ENTER will return to Top-Bottom adjustment menu
EXIT will return to Geometry menu

Horizontal Size Adjustment

Use the arrow keys to highlight **H SIZE** on the Geometry menu and then press **ENTER**.

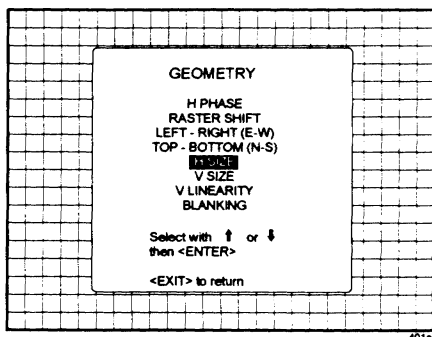

ENTER will select horizontal size adjustment
EXIT returns to random access adjustment mode menu.
ADJUST returns to operational mode

Adjust the horizontal size with the left and right arrow keys until the exact image width is obtained.

Note :

- if the internal # pattern was selected, this pattern remains on the screen.
- if the glocked pattern was

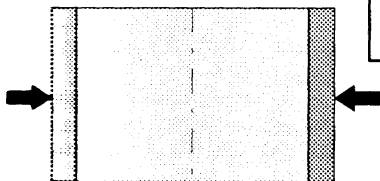
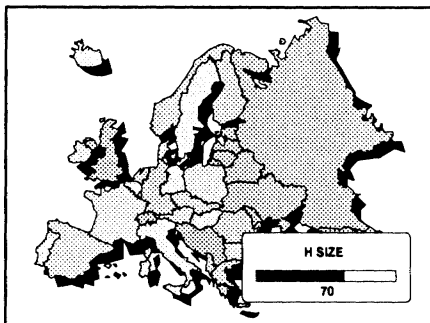

selected, the external source will be displayed.

A bar scale and a number indicator give a visual indication of the horizontal size adjustment.

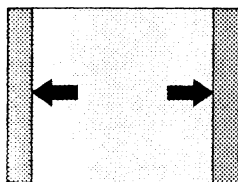

Hint : In order to avoid loss of resolution in the projected image and to ensure maximum CRT longevity, do not use an excessively small horizontal size setting.

EXIT will return to Geometry

Vertical Size Adjustment

Use the arrow keys to highlight **V SIZE** on the Geometry menu and then press **ENTER**.

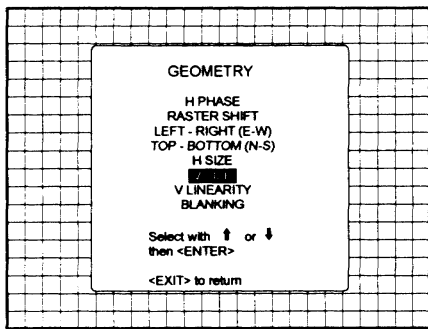

4011

ENTER will select vertical size adjustment
EXIT returns to random access adjustment mode menu..
ADJUST returns to operational mode

Adjust the vertical size with the up or down arrow key until the exact image height is obtained. Note :

- if the internal # pattern was selected, this pattern remains on the screen.
- if the genlocked pattern was

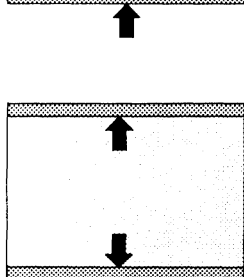
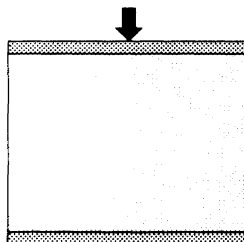
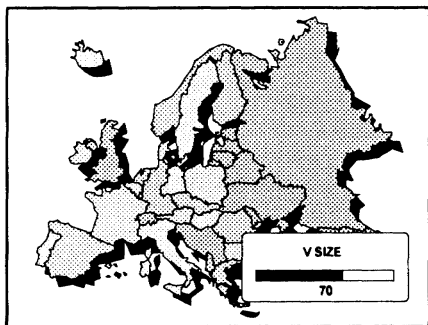

selected, the external source will be displayed. A bar scale and a number indicator give a visual indication of the vertical size adjustment.

Hint : In order to avoid loss of resolution in the projected image and to ensure maximum CRT longevity, do not use an excessively small vertical size setting.

EXIT will return to Geometry

Vertical Linearity Adjustment

Use the arrow keys to highlight *V LINEARITY* on the Geometry menu and then press **ENTER**.

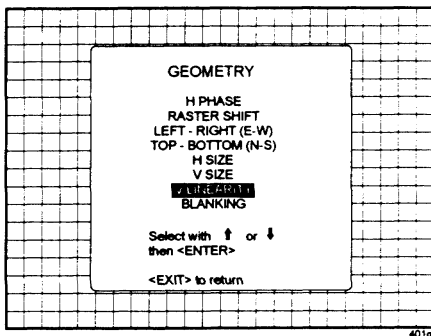

ENTER will select vertical linearity adjustment
EXIT returns to random access adjustment mode menu, menu R1.
ADJUST returns to operational mode

Adjust the vertical linearity with the arrow keys until the distances between the horizontal lines of the set up pattern are equal.

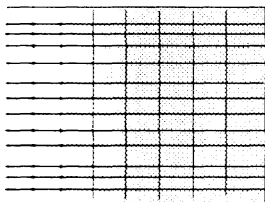
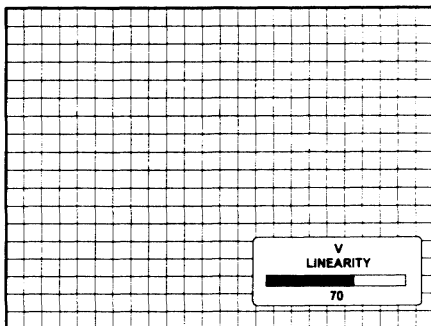

EXIT will return to the Geometry menu

Blanking Adjustments

Use the arrow keys to highlight **BLANKING** on the Geometry menu and then press **ENTER**.

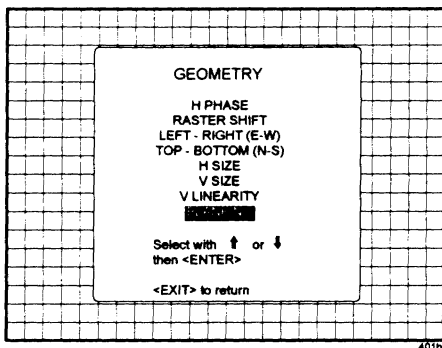

ENTER will select blanking adjustment menu **EXIT** returns to random access adjustment mode menu.
ADJUST returns to operational mode

Blanking adjustments affect only the edges of the projected image and are used to frame the projected image on the screen and to hide or black out unwanted information (or noise). A 0% on the bar scale indicates no blanking.

The following blanking corrections are possible :

- top blanking
- bottom blanking
- left blanking
- right blanking

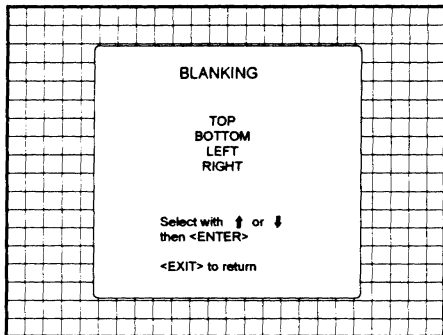

Therefore :

- if the internal # pattern was selected, this pattern remains on the screen.
- if the genlocked pattern was selected, the external source will be displayed.

EXIT will return to Geometry
ADJUST returns to operational mode

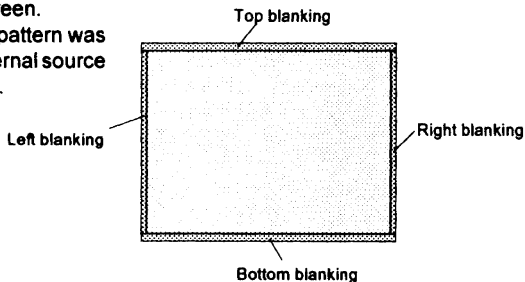

Top Blanking Adjustment

Use the arrow keys to highlight **TOP** on the Blanking menu and then press **ENTER**.

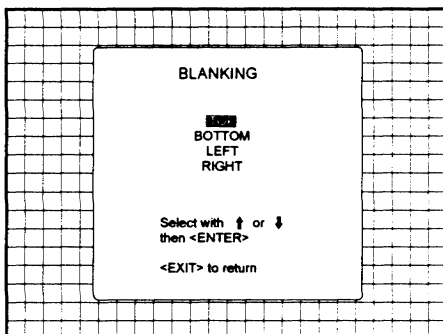

ENTER will select top blanking adjustment
EXIT will return to Geometry menu
ADJUST returns to operational mode

Use the up and down arrow keys to adjust the top blanking. Press **ENTER** to continue

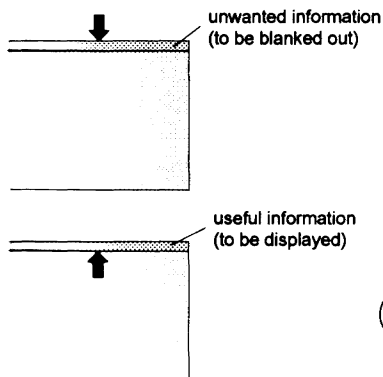
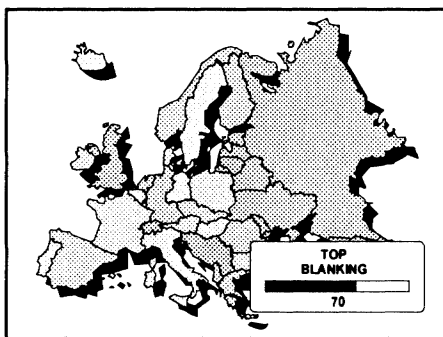

EXIT will return to the Blanking menu

Bottom Blanking Adjustment

Use the arrow keys to highlight **BOTTOM** on the Blanking menu and then press **ENTER**.

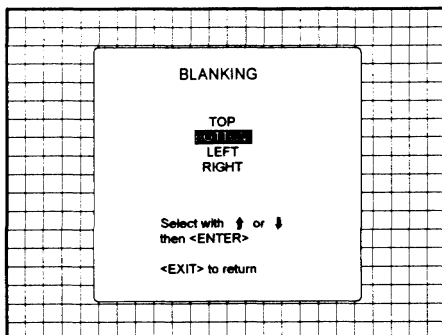

ENTER will select bottom blanking adjustment
EXIT will return to Geometry menu
ADJUST returns to operational mode

Use the up and down arrow keys to adjust the bottom blanking. Press **ENTER** to continue

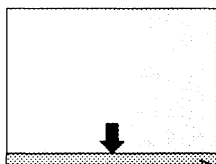
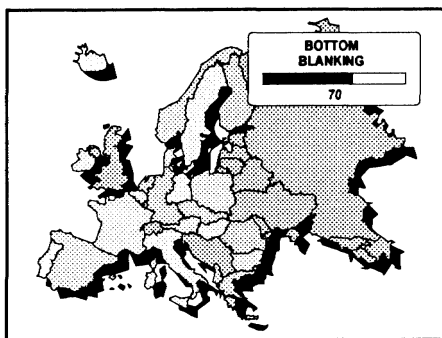

useful information
(to be displayed)

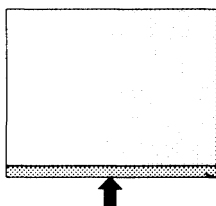

unwanted information
(to be blanked out)

EXIT will return to the Blanking menu

Left Blanking Adjustment

Use the arrow keys to highlight **LEFT** on the Blanking menu and then press **ENTER**.

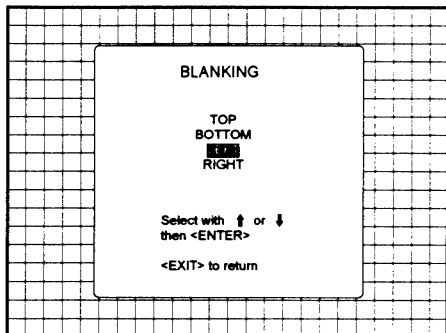

ENTER will select left blanking adjustment
EXIT will return to Geometry menu
ADJUST returns to operational mode

Use the left and right arrow keys to adjust the left blanking. Press **ENTER** to continue

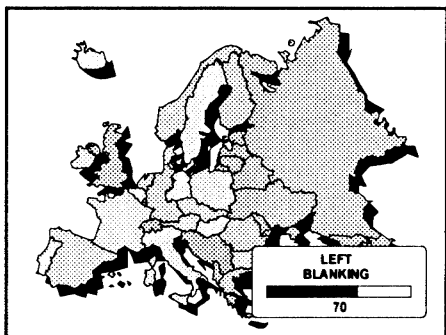

Unwanted information
(to be blanked out)

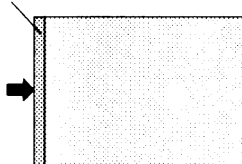

Useful information
(to be displayed)

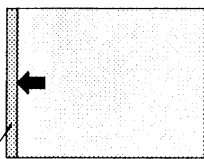

EXIT will return to the Blanking menu

Right Blanking Adjustment

Use the arrow keys to highlight *RIGHT* on the Blanking menu and then press **ENTER**.

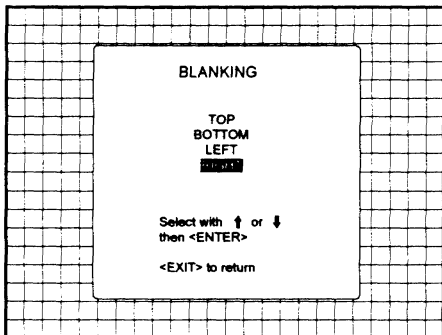

ENTER will select right blanking adjustment
EXIT will return to Geometry menu
ADJUST returns to operational mode

Use the left and right arrow keys to adjust the right blanking. Press **ENTER** to continue

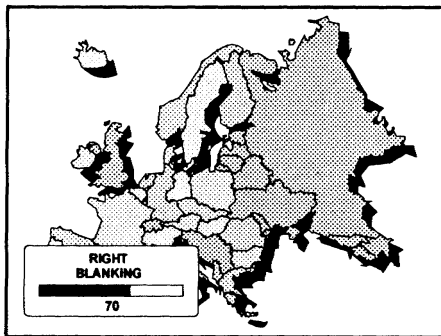

unwanted information
(to be blanked out)

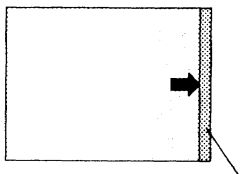
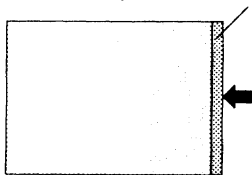

useful information
(to be displayed)

EXIT will return to the Blanking menu

Convergence Adjustment

Convergence adjustments affect both the horizontal and vertical lines of the setup pattern. These adjustments are performed on the red image while superimposed on the green image and then on the blue image while superimposed on the green image.

Note : the green convergence adjustments can be added as an option. When these are available, start always with 'green only'. This option will also be indicated on the convergence menu.

Highlight first 'Green only' when available with the arrow keys and press **ENTER** to display the convergence adjustment menu

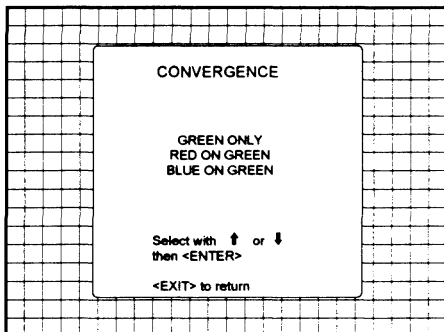

ENTER will display the Convergence menu.
EXIT will return to Random Access Adjustment Mode main menu.
ADJUST returns to operational mode.

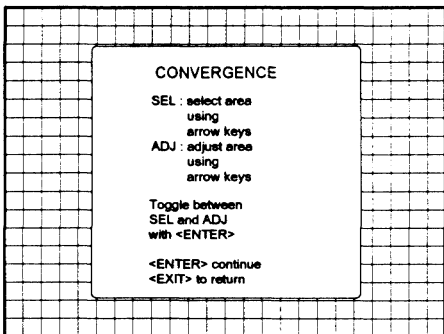

ENTER will continue to convergence adjustment
EXIT returns to convergence menu.

RANDOM ACCESS ADJUSTMENT MODE

The screen area is divided into 13 areas. Use the arrow keys to move the box to the desired zone and then press **ENTER** to begin the convergence adjustment. Start the convergence adjustment with zone one and continue as mentioned in the diagram hereafter.

25	23	9	15	17
24	22	8	14	16
5	4	1	2	3
20	18	6	10	12
21	19	7	11	13

307

Use the arrow keys to make horizontal or vertical convergence adjustments in the selected zone and then press **ENTER** to move the box to another zone or **EXIT** to return to the Convergence menu.

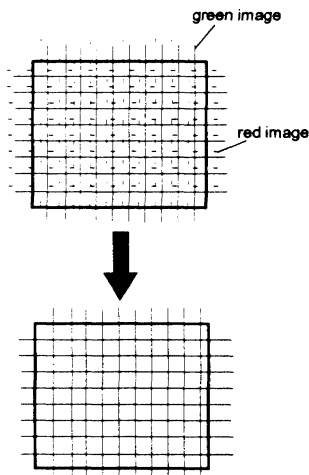
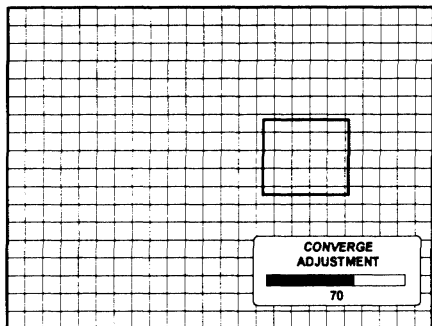

ENTER toggles arrow keys between zone selection and zone adjustment .
EXIT returns to convergence menu

SERVICE MODE

Starting up the service mode

Overview flow chart Service mode

Start up screen

Copy a block

Deletion of blocks

Change password

Run time

Set to midposition

Convergence off

CRT Run in cycle

Dyn. Astigmatism

only for BGR1208 art. no. 90 00891 - 90 00898)

Starting up the service mode.

Use the arrow keys to highlight 'Service' and then press ENTER.

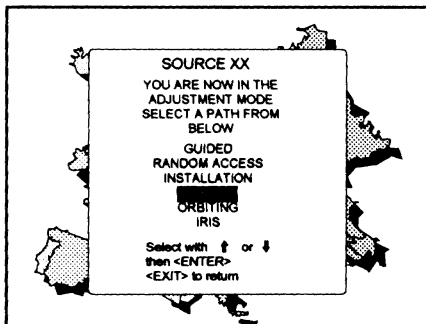

298d

ENTER continues to service mode main menu.

EXIT returns to operational mode.

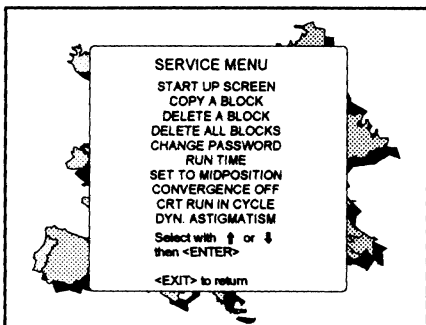

407

Overview flowchart 'Service' mode.

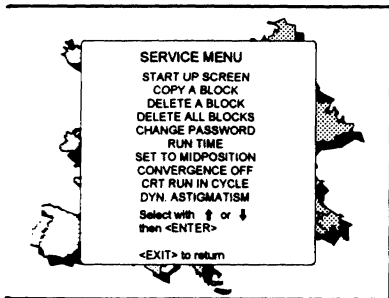

407

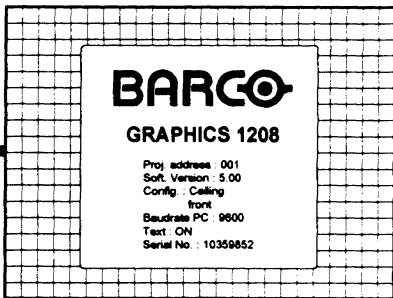

812

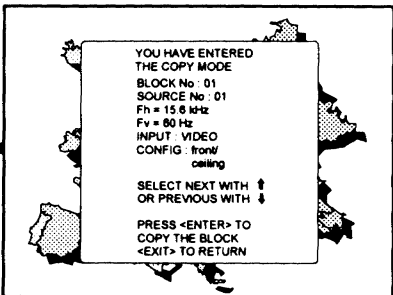

411

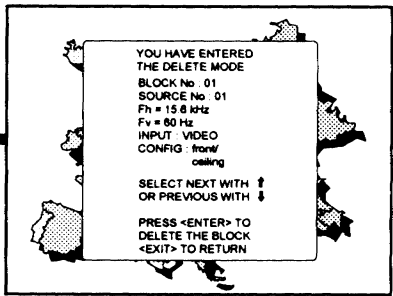

410

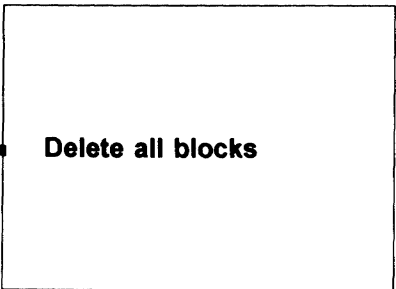

PASSWORD

ENTER NEW PASSWORD

1 0 0 2

USE THE ARROW KEYS
TO SELECT OR
PROGRAM WITH
NUMERIC KEYS

<ENTER> TO CONFIRM

<EXIT> TO RETURN

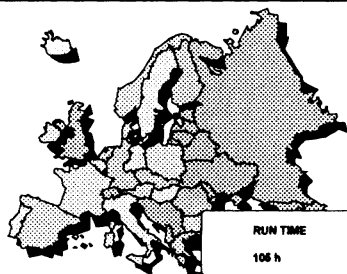
**Set to midposition****Convergence off****CRT run in cycle****Dyn. Astigmatism**

Start up screen

Highlight 'Start up screen' with the arrow keys and press ENTER.

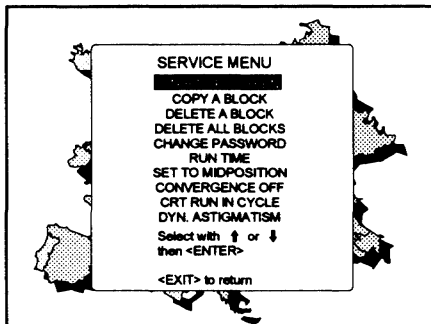

ENTER displays the start up screen.
EXIT returns to the Path selection main menu.

The 'Start up screen' screen gives information concerning :

- projector address. To change the address of your projector, contact a qualified service technician.
- software version.
- configuration.
 - possible installations :
 - * front-ceiling
 - * front-table
 - * rear-ceiling
 - * rear-table

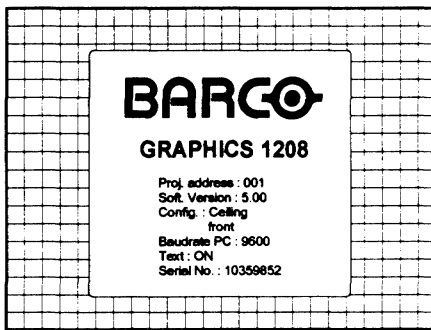

- baud rate PC : transfer speed for communication with a IBM PC (or compatible) or MAC. The baud rate of the projector must be the same as the baud rate of the connected computer. When there is a difference, contact a qualified service technician to make the appropriate changes.

- Text ON/OFF

Indicates in operational mode if the bar scale and number indicator will be displayed and if warnings and failures will be displayed.

ON : displayed

OFF : not displayed

The status can be changed by pressing the 'TEXT' key once on the RCU 800.

- Serial no. : indicates the fabrication number of the projector. This number can be useful when calling for technical assistance.

Copy a block

The Copy a block function copies the settings of a selected block into the active block.

Highlight 'Copy a block' with the arrow keys and press ENTER.

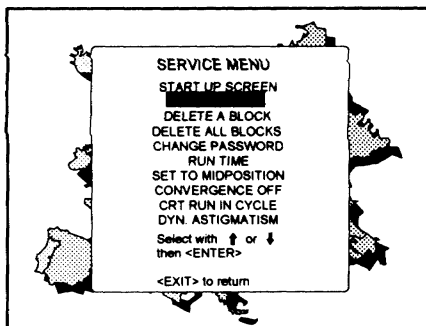

ENTER displays the copy menu
EXIT will returns to the Path selection main menu.
ADJUST will returns to operational mode.

A first block header will be displayed in the copy menu.
 To select the desired block :

1. Use the up and down arrow keys on the RCU800 to scroll through the adjustment blocks. The contents of each block header are displayed on the copy menu.
2. Press ENTER to copy the selected adjustment block. A 'confirmation' screen appear on the screen.
3. If you are sure you wish to copy the block, press ENTER. EXIT returns without copying the block.

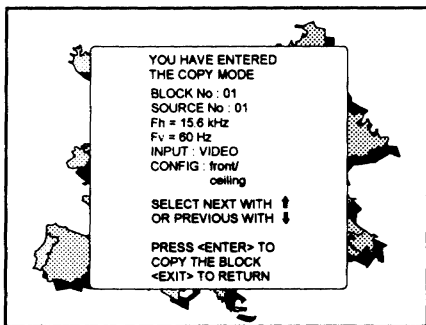

ENTER displays the confirmation menu.
EXIT returns to service mode without copying.

Deletion of blocks

This item is password protected.

The delete function is used to clear all data (settings) from an adjustment block
A delete can be given :

- block by block
- or
- for all blocks.

Deleting block by block

The delete a block function deletes the settings of a selected block.

Highlight 'Delete a block' with the arrow keys and press ENTER.

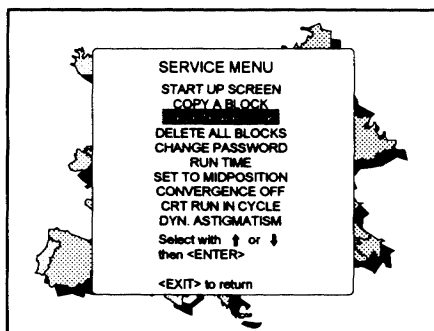

407

ENTER will select the delete menu
EXIT returns to the path selection main menu
ADJUST returns to operational mode..

A first block header will be displayed in the delete menu.

To select the desired block :

1. Use the up and down arrow keys on the RCU800 to scroll through the adjustment blocks. The contents of each block header are displayed on the delete menu.
- 2 Press ENTER to delete the selected adjustment block. A 'confirmation' message will appear on the screen.

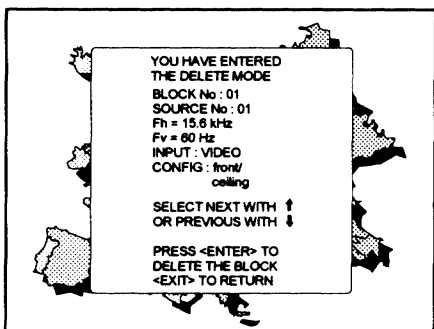

410

3. If you are sure you want to delete the block, press **ENTER**. The deleted block number returns but all fields are blanked. *Once **ENTER** is pressed, the block header and adjustment settings are definitely removed and can not be restored.*

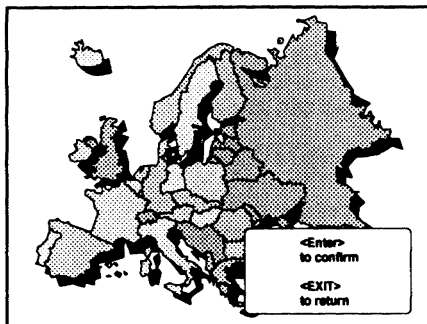

412

4. If another block has to be deleted, use the up and down arrow keys to scroll through the adjustment blocks and repeat the delete procedure as above. Otherwise, press **EXIT** to return to the operational mode.

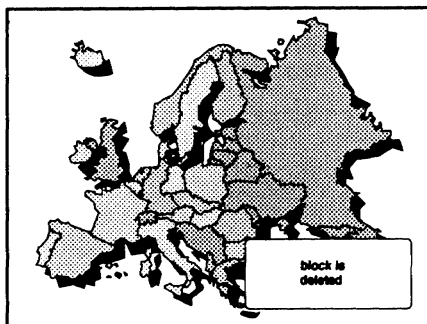

413

Deletion of all blocks

The delete all blocks function *deletes all the settings in all the adjustment blocks.*

Highlight 'delete all blocks' with the arrow keys and press **ENTER**.

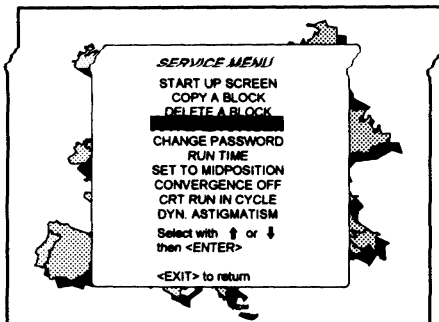

407

ENTER gives a confirmation message before deleting.
EXIT returns to the path selection main menu

If you are certain you wish to delete all blocks, press **ENTER** to confirm, otherwise press **EXIT** to return.

Once **ENTER** is pressed, all block headers and adjustment settings are permanently removed and cannot be restored.

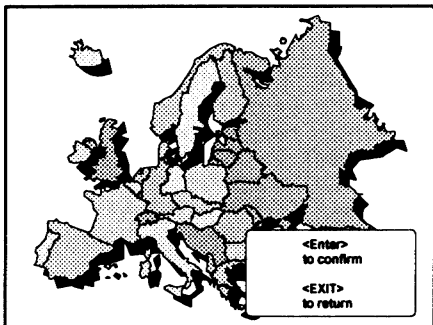

412

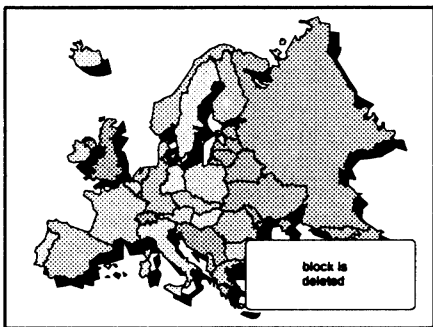

413

Change password

The change password function allows the user to change the *actual password into a new password*.

Highlight 'change password' with the arrow keys and press **ENTER**.

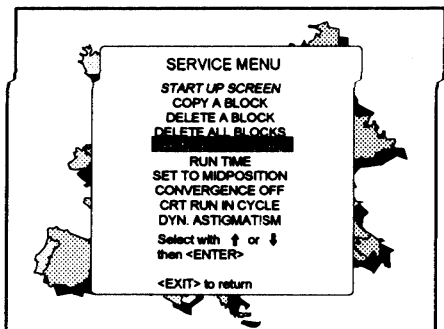

407

ENTER will display the Password menu.
EXIT will return to the Path selection main menu.
ADJUST will return to operational mode.

The current password is displayed. The new password must consist of 4 digits between 0 and 9. Use the left and right arrow keys to select the digits to be changed. Use the numeric keys to enter the new digits. Press **ENTER** to save the new password and to return to the Service mode menu. Press **EXIT** to return to the Service menu without saving the new password.



406

ENTER returns to service mode menu and saves the new password.

EXIT returns to service mode without saving the new password.

Run time

Highlight 'run time' with the arrow keys and press **ENTER** to display the amount of time the projector has played since its first start up at the factory.

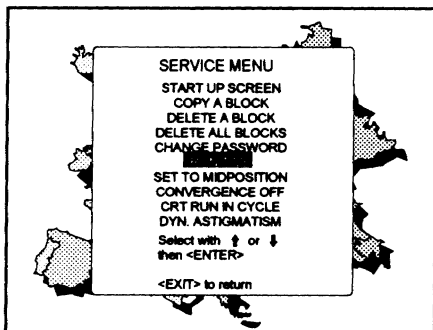

407

ENTER gives the Run time.

EXIT returns to the Path selection main menu.

ADJUST returns to operational mode.

SERVICE MODE

Note : all projectors leave the factory after a burn-in period of approximately 100 hours.

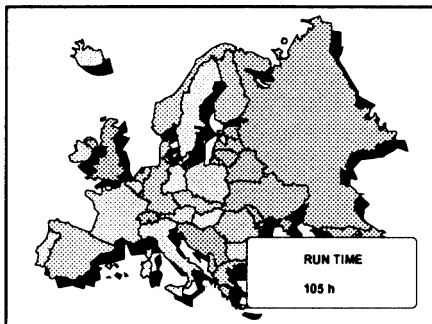

ENTER returns to the Service mode main menu.

Set to midposition

Highlight '*set to midposition*' with the arrow keys and press **ENTER** to set all settings in their midposition.

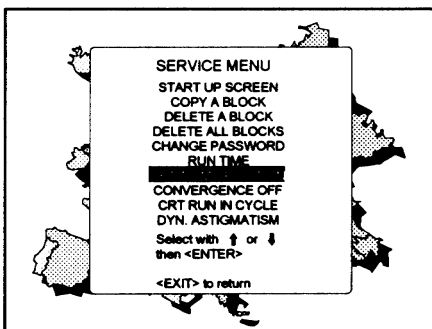

407

ENTER returns to the service mode main menu and sets all settings to their midposition.

EXIT returns to the path selection main menu

ADJUST returns to operational mode.

Convergence off

Highlight '*convergence off*' with the arrow keys and press ENTER to set all convergence settings to their midposition.

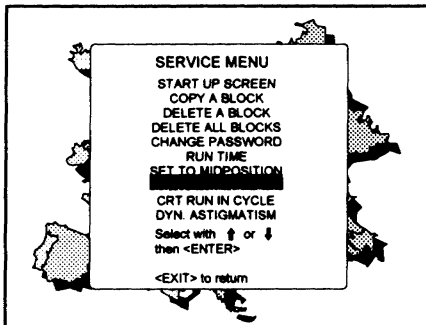

407

ENTER returns to the Service mode main menu and sets all convergence settings to their midposition.

EXIT returns to the path selection main menu

ADJUST returns to operational mode.

CRT run in cycle

The CRT run in cycle option can only be activated when memory blocks on an internal # pattern are available. When one or more such blocks are available, a flashing white image (5sec on, 5 sec off) is generated and that for 5 min on the first internal block. In the next 5 min, a second internal block will be used to generate the flashing white image. The image will also be shifted in a vertical way to prevent a CRT burn in. To quit the CRT run in cycle option, press EXIT.

Highlight '*CRT run in cycle*' with the arrow keys and press ENTER to start .

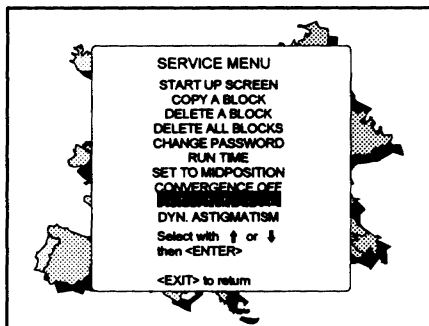

407

ENTER selects the CRT run in cycle option.

EXIT returns to the path selection main menu

If a memory block adjusted on an internal # pattern is available, the CRT run in cycle will start when pressing ENTER. If no such a block is available, the projector cannot run the CRT run in option and leaves the adjustment mode. If you still want to run CRT run in cycle, create first a memory block on an internal # pattern and restart the CRT run in option.

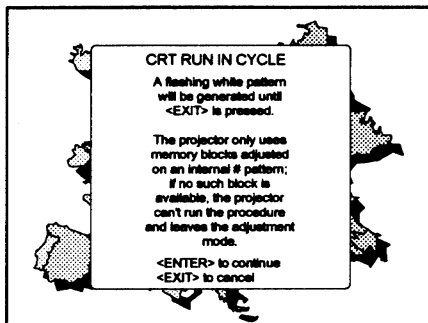

787

ENTER starts the 'CRT run in' when an internal generated # pattern is available.
EXIT returns to the path selection main menu

Dynamic Astigmatism (spot shape adjustment)

The spot shape adjustments correct the spot shape in 8 different areas on the screen and that for the three colors separately.

The spot shape is adjusted according to the axial axes and the diagonal axes when using the arrow keys on the RCU.

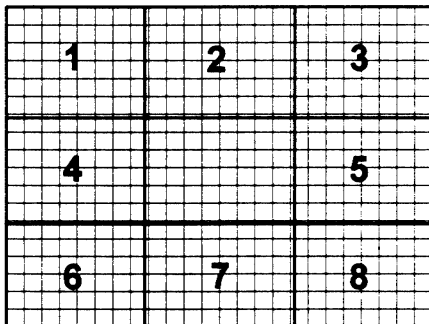

Spot shapes before dynamic astigmatism correction



Diagonal astigmatism correction (use the ↑ and ↓ arrow key)

Axial astigmatism correction (use the ← and → arrow key)

Spot shapes after dynamic astigmatism correction



These adjustments have to be done on a dot pattern (e.g. the internally generated pattern) with standard line frequency (15kHz). The adjustment values are stored in the EEPROM and remain the same for all frequencies.

Follow the next procedure :

Highlight 'Dyn. Astigmatism' with the up or down arrow key and press ENTER to select.

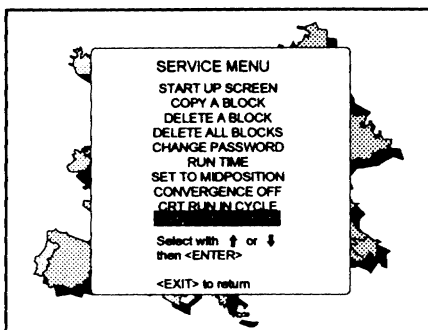

407

ENTER selects the Dyn. Astigmatism color selection menu.

EXIT returns to the path selection main menu

Select the source type, selected source or genlock pattern, by highlighting the color for which the spot shape has to be corrected and press ENTER.

e.g. when selecting RED under 'on genlocked pattern', the projector switches to a genlocked pattern.

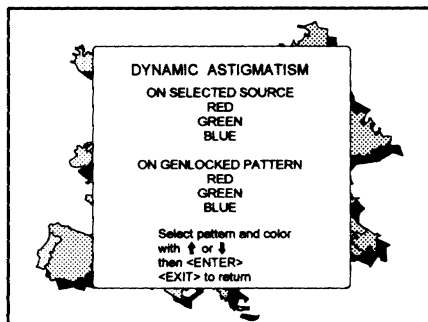

818

ENTER displays the selected color.

EXIT returns to the service main menu.

Press **ENTER** to continue adjustment.

Increase the contrast level to display a bigger spot. Press **ENTER** to continue to **SEL**.

SEL : select the adjustment area on the screen where the spot shape has to be corrected.

Use the arrow keys to select one of the 8 areas. Press **ENTER** to continue to **ADJ**.

ADJ : adjust the spot shape in the axial or diagonal direction when using the arrow keys for the selected area. Adjust until the spot shape is circular.

Use the up and down arrow keys for the diagonal astigmatism adjustment and the left and right arrow keys for the axial astigmatism adjustment. Press **ENTER** to continue selecting a new area.

The adjustment direction (axial or diagonal) and adjustment value are given in a text box on the screen. When all areas are adjusted, press **EXIT** to return to the service main menu.

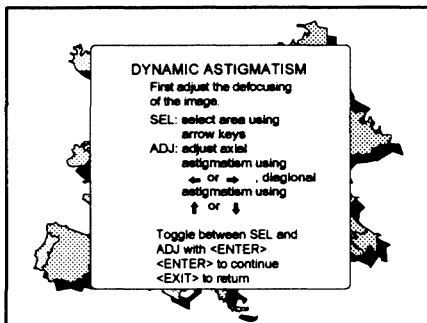

MESSAGES, WARNINGS AND FAILURES

SOURCE 01
Fh= 15.6 kHz
Fv= 050 Hz

When selecting a new source, information about this source will be displayed on the screen. Source number, horizontal and vertical frequencies of the displayed source.

SOURCE 01

Announcement of the selected source.

enter
password
x x x x

Message to enter your password. Password contains 4 digits.

text on

These messages will be displayed on the screen when pushing the TEXT key.

Text ON : the '*bar scale indication*' will be enabled during the change of an analog control in the '*operational mode*' + all warnings and failures will be displayed.

text off

Text OFF : the '*bar scale indication*' will be disabled during the change of an analog control in the '*operational mode*' + all warnings and failures will not be displayed.

PROJECTOR
ADDRESS :
003

Indication of the projector address when activating the 'ADDRESS' button on the RCU with a pencil or other small object.

WARNING :

input not
available

When using the projector with the RCVDS 800, this warning will be displayed when selecting an input slot of an RCVDS where the input board is missing.

WARNING :

**source not
available**

The input is a valid input but the source is not connected to the input terminals or the input source is switched off.

WARNING :

**invalid
key entry**

When a wrong key is pressed on the RCU.

WARNING :

**invalid
code entry**

Message when the entered password is wrong.

WARNING :

**end of ad-
just range**

End of adjustment range.

WARNING :

**input no
longer
available**

Message will be displayed when the input source is no longer available. The following message then appears: *'check input signal or select new source'*.

**check in-
put signal
or select
new source**

Message will be displayed after the message *'input no longer available'*. It asks to check the connections between the source and the projector or to check if the source is switched on.

WARNING :

**input se-
lector not
available**

It warns you to check the power connection or the power status of the RCVDS800.
Next message will appear immediatly on the screen : *'go to stand-by'*.

MESSAGES, WARNINGS AND FAILURES

WARNING :

go to
stand by

Projector will switch to 'stand-by' when the RCVDS 800 is no longer available.

WARNING :
invalid
frequency
input

The entered frequency or applied frequency of the source is out of the projector's range.

WARNING :
default
settings
loaded in
the E2PROM

Adjustment settings are lost. Re-load using Control 800 Software via PC or MAC, or readjust image.

table is
deleted

Message to inform that selected table is deleted. This message will be followed by 'confirm message', on which the user has to answer.

FAILURE
invalid
RWI soft
version

Wrong software version in your projector. Call for technical support.

FAILURE

I2C error
addr. : 7FH3

Hardware failure. Call a qualified service technician for repair.

FAILURE
short
circuit on
I2C bus

Hardware failure. Call a qualified service technician for repair.

FAILURE
RCVDS com-
munication
error

Serial communication error between RCVDS800 and projector.

**FAILURE
RWI commu-
nication
error**

Hardware failure. Call a qualified service technician.

**FAILURE
IRIS commu-
nication
error**

Communication error between IRIS 800 and the projector. Call a qualified service technician.

**WAIT
starting
up
IRIS**

Message during the start up of the IRIS 800. Message will disappear when the IRIS 800 is ready to accept commands.

OPTIONS

IR receiver 800

Hardwired RCU800

Projector control software

RCVDS 800

IRIS 800

Adapter and communication cables

Orbiting Kit

Soft edge matching kit

Contrast modulation kit

Flight case

Suspension system

IR Receiver 800

This infra red receiver unit makes it possible to control the BARCOGRAPHICS 1208 from another room.

There is a communication line with cable between the IR receiver and the projector or the RCVDS 800. The control information from the RCU can now be sent to this IR receiver.

The IR receiver 800 displays the selected source on a 7-segment display.

Order number : 98 27515

Hardwired RCU.

The control signals from the RCU can be sent to the projector via a wired connection.

Assembling a remote cable :

Use a shielded cable with a maximum length of 100 m (330ft) and two mini-jack 2.5 mm connectors (order number : 31 3043).

- Peel back the vinyl covering of the cable on both sides and twist the wire core.

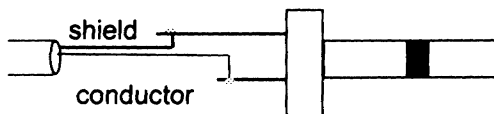

- Solder a jack plug as shown in drawing above to each end of the cable.
 shield = ground
 conductor = data information

When the cable is ready, plug one side in the remote control and the other side in the connector on the rear of the projector labelled 'remote'.

Projector control software

The software is user-friendly and makes full use of : mouse control, pull down menus, dialog boxes.

Two main applications are available with this software : remote control and transferring and receiving data of projector settings.

remote control access. Advantage : address range 0 to 255.

adjustment data : where can it be located when a IBM PC (or compatible) or MAC or Workstation is connected :

- hard memory device with files of settings.
- the contents of the local memory of the computer.
- the contents of the projector.

RCVDS 800

An optional RCVDS 800 source selector makes it possible to connect up to ten sources to the projector. To maximize the flexibility of the projector, an optional expansion module makes it possible to link ten source selectors in series, enabling the simultaneous connection of up to 90 sources to the projector.

IRIS 800

Easy-to-use, high precision automatic convergence system.

Using the IRIS 800's user-friendly onscreen displays, the unit effortlessly aligns the projected image on the screen faster and more accurately than ever previously possible through the conventional 'manual' convergence process.

The flexible design of the IRIS 800 allows it to operate either in a table or ceiling mount installation.

Adapter and communication cables

BARCO provides several cables to connect peripheral equipment to the BARCOGRAPHICS 1208.

a. D9-D9 communication cable

- To connect an IBM PC (or compatible) to the projector. (only if the optional RS232 port is installed.)
- To connect a RCVDS 800 to the BARCOGRAPHICS 1208.
- To connect a IR receiver to the RCVDS800 or to the BARCOGRAPHICS 1208.
- To be used as extension cable for all other adapter cables.

Available length : 5m (16ft), order number 98 27770; 15 m (49ft), order number 98 27560; and 30 m (98ft), order number 98 27570; 30 m (98ft) high quality, order number : 98 27870.

b. Din Mini8-D9 adapter cable.

- To connect a Macintosh computer to the BARCOGRAPHICS 1208.
- Available length : 1 m, order number 98 27640.

c. D25-D9 adapter cable

- To connect a workstation to the BARCOGRAPHICS 1208.
- Available length : 1 m, order number 98 27630

d. D9 - BNC Cable adapter

- To connect a second RGB source to Port 3 the BARCOGRAPHICS 1208.
- Order number 98 27840.

Orbiting Kit

Static pictures are very often shown on large screen projectors, especially in process control and presentation applications. Due to the fact that the same picture information is shown for a long period in the same place, picture tubes can be damaged by 'local burn-in'. To avoid this problem, a special Orbiting circuit is available which moves the picture very slowly around a predefined screen area. The cycle time is very long to make the movement of the projected image imperceptible. The use of the orbiting kit is described in appendix A.

Order number : 98 27780

Soft edge matching kit

Multi-screens are popular for many applications. In these installations, the goal is to obtain a contiguous matched image, forming one homogenous view. The soft edge matching feature provides a solution to the annoying side effects when adjusting two or more projected images next to each other. To improve this junction, both images must be overlapping within a certain percentage of the total screen width. During the overlapping period, both video signals are modulated by appropriate waveforms so that the resulting light output equals the rest of the image. The use of the soft edge matching kit is described in appendix B.

Order number : 98 27810

Contrast modulation kit

The contrast modulation kit is designed to improve overall light output uniformity and to overcome the inherent color shift errors, normally associated with CRT projection. The laws of physics applied to projection optics dictate that the center of the projected image will be brighter than the corners, this phenomenon is normally referred to as 'corner fall off'. Due to the normal off-axis projection of the red and blue images, CRT projection displays a phenomenon referred to as 'color shift', whereby one side of the image is redish and the other blueish. By modulating the amplitude of the video signal with appropriate waveforms we are able to overcome both problems.

The use of this contrast modulation kit is described in appendix C.

Order number : 98 27800

Flight case

Sturdy, easily transportable flight case, for the packing of the BARCO 1200 projectors

Order number : 98 27650

Suspension system

Barco's suspension system allows any 800 and 1000 series projector to be mounted from the ceiling, adapting the projector perfectly to the local mounting requirements.

Order number : 98 27340

Orbiting

Static pictures are very often shown on large screen projectors, especially in process control and presentation applications. Due to the fact that the same picture information is shown for a long period on the same place, picture tubes can be damaged by 'local burn-in'. To avoid this problem, BARCO has designed special Orbiting circuitry which moves the picture very slow around a predefined screen area. The orbiting circuitry has been designed using a very long cycle time to make the movement of the projected image imperceptible.

Adjustment procedure :

The orbiting path is automatically added to the Path selection menu when installed. Press **ADJUST** to enter the adjustment mode.

The Path Selection menu will be displayed.

Highlight **ORBITING** with the arrow keys and press **ENTER**.

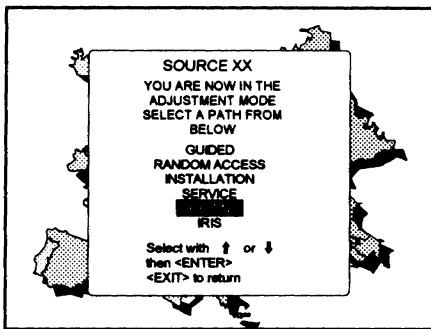

298e

ENTER continues to the Master Orbiting menu.
EXIT returns to operational mode.
ADJUST returns to operational mode.

Orbiting mode toggle switches

The orbiting module is provided with a three pins connector for connection with the BARCO's BCI link option module, used in multiple projector installations. For Orbiting, one projector operates as master whereas the others operate as slave.

Master/slave toggle

Highlight '**CHANGE TO SLAVE**' with the arrow keys and press **ENTER** to set the projector as Slave.

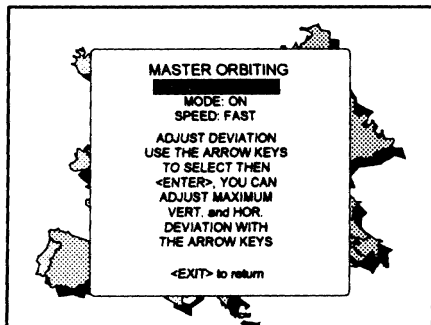

296a

Highlight '**CHANGE TO MASTER**' with the arrow keys and press **ENTER** to set the projector as Master.

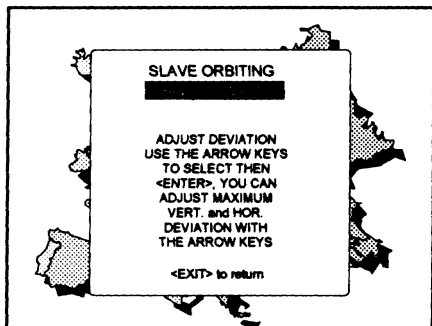

297a

Orbiting ON/OFF toggle (only in Master Orbiting)

Highlight '**MODE : ON**' with the arrow keys and press **ENTER** to set the ORBITING OFF.

Highlight '**MODE : OFF**' with the arrow keys and press **ENTER** to set the ORBITING ON.

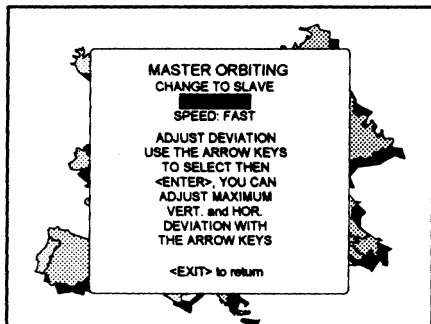

298a

ENTER toggles between mode on and off.
EXIT returns to the Path selection menu.

Orbiting speed toggle (only in MASTER Orbiting)

Highlight '**SPEED : SLOW**' with the arrow keys and press **ENTER** to set the ORBITING SPEED to Fast.

Highlight '**SPEED : FAST**' with the arrow keys and press **ENTER** to set the ORBITING SPEED to Slow

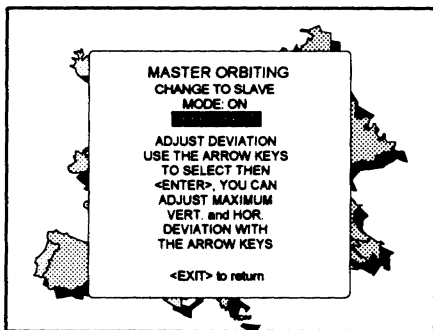

ENTER continues to Set up Orbiting
EXIT returns to path selection menu
ADJUST returns to operational mode.

Orbiting alignment

Preparation :

Before proceeding to the alignment of the Orbiting default settings, be sure that the Horizontal Phase and the Raster shift are correctly aligned with the Orbiting mode set to OFF.

This alignment must be performed in case of a multiple projector installation with Master and Slave projectors in order to ensure a correct operation of the Orbiting for all projectors.

Adjustment procedure stand alone projector :

Highlight '**ADJUST DEVIATION**' with the arrow keys and press **ENTER**.

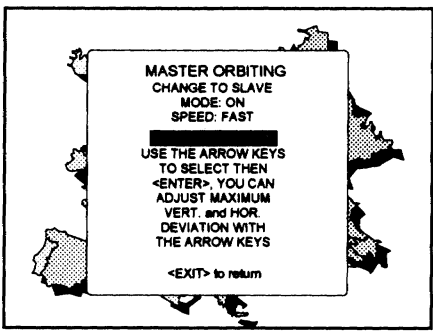

When adjusting the horizontal and the vertical deviation, the picture moves in the corresponding direction, allowing the set up of the deviation without orbiting operation.

Press the left (right) or up (down) arrow key to toggle between Hor. and Vert. deviation adjustment.

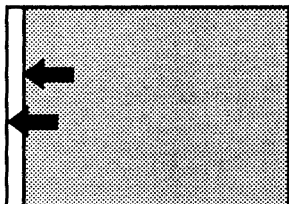

Adjust horizontal deviation with left and right arrow key.

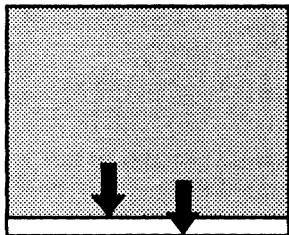

Adjust vertical deviation with up and down arrow key.

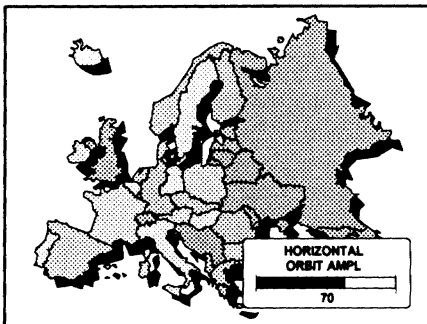

299

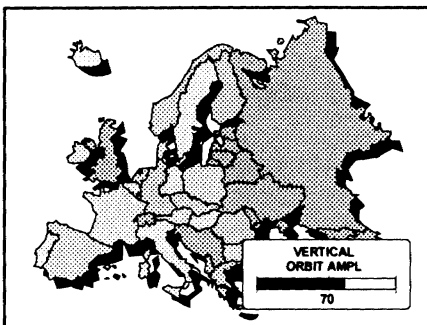

300

ENTER will select the Orbiting adjustment menu.

EXIT returns to the Path selection menu.

Adjustment procedure multiple projector installations :

Important : to allow corrections in the deviation alignments of the slave projectors, never adjust the deviations of the master projector to its maximum.

Default setting of the Master projector see 'Stand alone projector'.

Highlight '*ADJUST DEVIATION*' with the arrow keys and press **ENTER**.

When adjusting the horizontal and the vertical deviation, the picture moves in corresponding direction, allowing the set up of the deviation without orbiting operation.

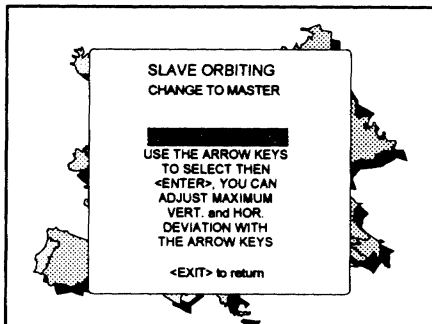

297b

Press the left (right) or up (down) arrow key to toggle between Hor. and Vert. deviation adjustment.

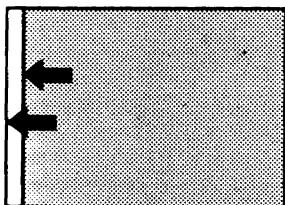

Adjust horizontal deviation with left and right arrow key.

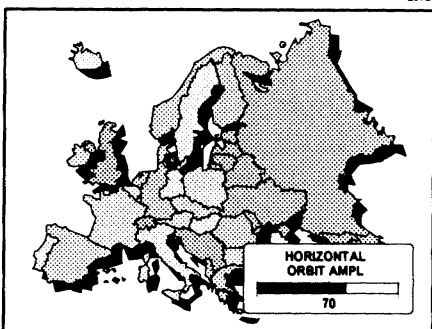

299

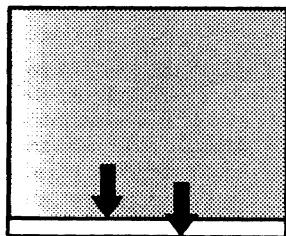

Adjust vertical deviation with up and down arrow key.

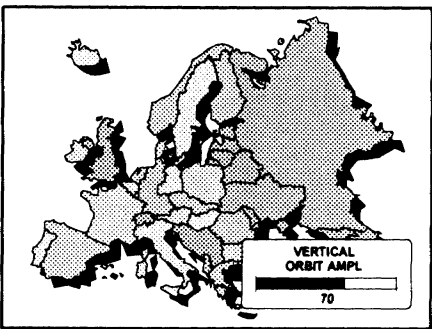

300

ENTER will select the orbiting adjustment menu.

EXIT returns to the Path selection menu.

Soft edge matching

Multi-screens are popular for many applications. In these installations, the goal is to obtain a contiguous matched image, forming one homogenous view. The soft edge matching feature provides a solution to the annoying side effects when adjusting two or more projected images next to each other. To improve this junction, both images must be overlapping within a certain percentage of the total screen width. During the overlapping period, both video signals are modulated by appropriate waveforms so that the resulting light output equals the rest of the image.

Picture with hard edging



Picture with overlapping



Picture with soft edging



Basic concept

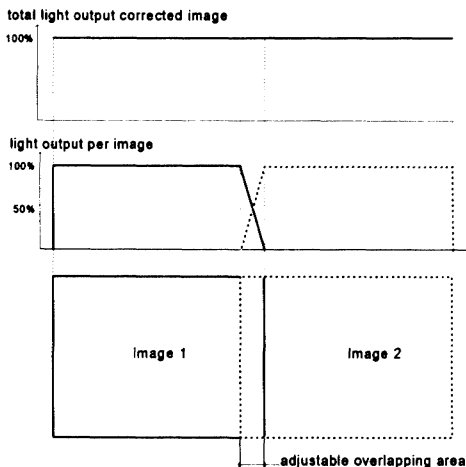

Adjustment procedure :

Start up the adjustment mode by pressing **ADJUST** (see also chapter 'Start up of the adjustment mode')

Highlight *Random access* with the arrow keys and press **ENTER** to start up the random access adjustment mode (see also chapter Random access adjustment mode). The *random access adjustment mode main menu* will be displayed.

When the *Soft edge matching option* is installed, the projector automatically detects this option and displays the selection (activation) line in the random access adjustment mode main menu.

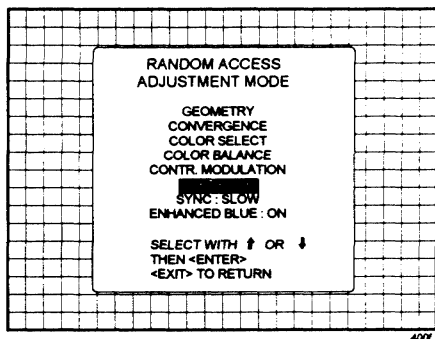

Highlight **SOFT EDGE** with the arrow keys and press **ENTER** to select.

The soft edge correction menu offers the possibility to display a horizontal test pattern and a vertical test pattern. When the test patterns are ON, the 'real' soft edge is disabled, marking lines for the start and stop position of soft edging and the overlapping area are displayed. When the test patterns are OFF, the 'real' soft edge is enabled again.

ENTER displays the soft edge matching menu.

EXIT returns to the Path selection menu.

ADJUST returns to operational mode.

Note : blanking corrections must be set to display a normal video image.

Each overlap area (left and right) is determined by a start (stop) position and an area width.

The start (stop) position for the top (bottom) overlap area is determined by the blanking adjustment.

Highlight *HTESTMODE* and press **ENTER**.

The test image is enabled to adjust the start (stop) position and the area width.

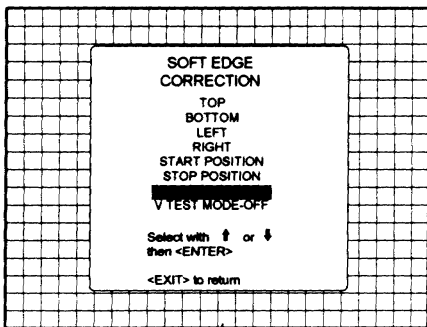

339g

ENTER toggles between H test mode OFF and ON.
EXIT returns to the random access adjustment mode main menu.
ADJUST returns to operational mode.

The test image is projected on the normal image

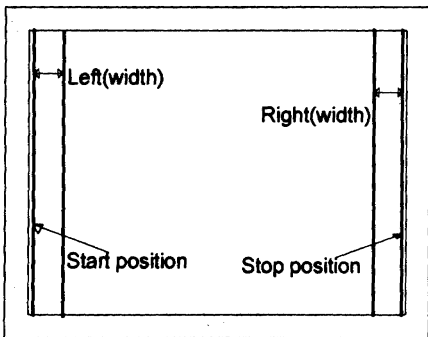

415

Raster
 Image
 ————— Visible lines

Start position

Highlight *START POSITION* with the arrow keys and press **ENTER**.

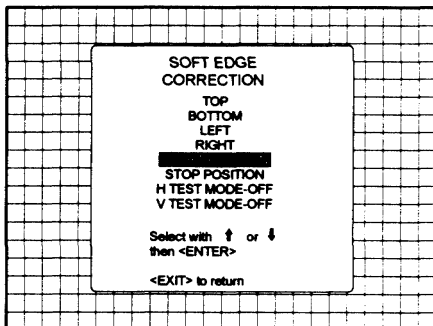

139a

ENTER displays the normal image superimposed with the internal generated test signal.

EXIT returns to the random access adjustment mode main menu.

ADJUST returns to operational mode.

Adjust the first left line of the generated test image to determine the image border. This image border is the start position of the soft edge area.

Note : when the start position is not visible by the first image display, adjust with the arrow keys until the line becomes visible. Adjust then until the start position is correct.

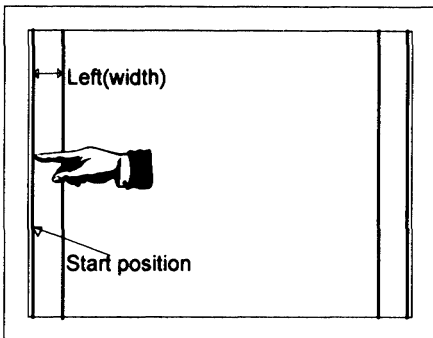

415a

ENTER displays the soft edge menu.

Left image area

Highlight *LEFT* with the arrow keys and press **ENTER**.

The normal image superimposed with the test pattern will be displayed.

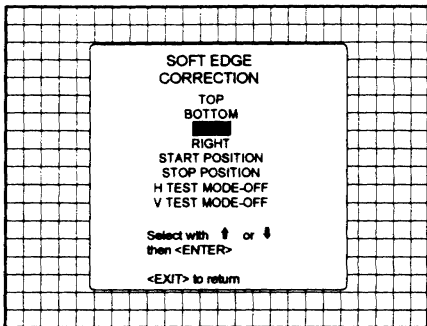

330c

ENTER displays the normal image superimposed with the internal generated test signal.

EXIT returns to the random access adjustment mode main menu.

ADJUST returns to operational mode.

Adjust the left soft edge area width by moving with the arrow keys the second test pattern line towards its desired position.

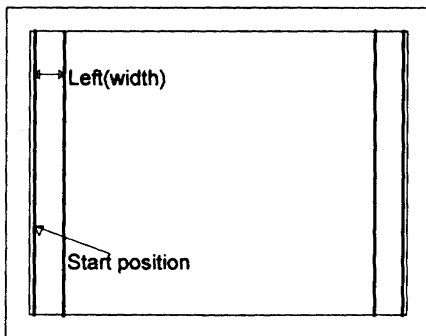

415a

ENTER returns to the soft edge correction menu.

Stop position

Highlight *STOP POSITION* with the arrow keys and press **ENTER**.

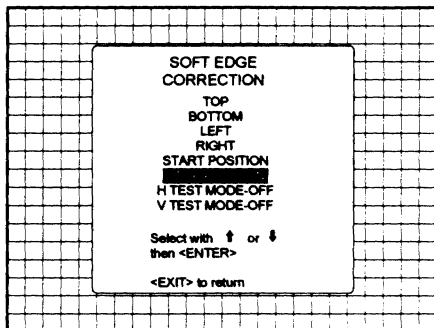

339f

ENTER displays the normal image superimposed with the internal generated test signal.
EXIT returns to the random access adjustment mode main menu.
ADJUST returns to operational mode.

Adjust the last right line of the generated test image to determine the image border. This image border is the end position of the right soft edge area.

Note : when the stop position is not visible by the first image display, press on the arrow keys until the line becomes visible. Adjust then until the stop position is correct.

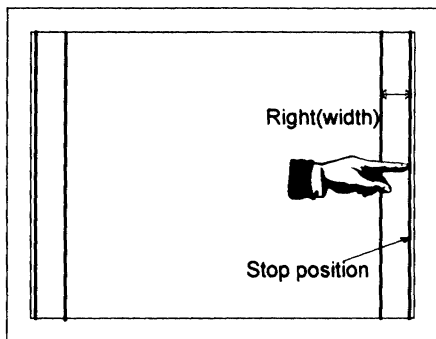

415b

ENTER displays the soft edge menu.

Right image area

Highlight *LEFT* with the arrow keys and press **ENTER**.

The normal image, superimposed with the test pattern will be displayed.

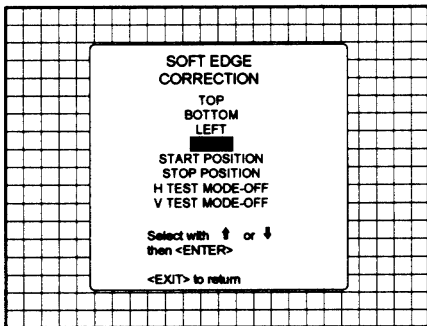

ENTER displays the normal image superimposed with the internal generated test signal.

EXIT returns to the random access adjustment mode main menu.

ADJUST returns to operational mode.

Adjust the right soft edge area width by moving with the arrow keys the second test pattern line towards its desired position.

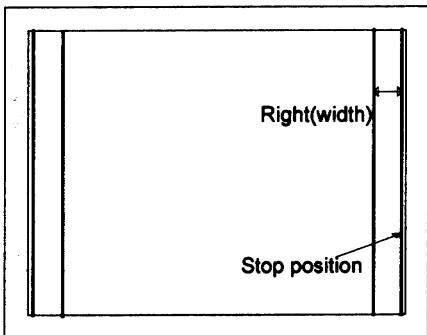

ENTER returns to the soft edge correction menu.

Vertical test mode

Highlight 'V TEST MODE' and press ENTER.

The test image is enabled to adjust the start (stop) position and the area width.

When switching the V test mode to On, the H test mode will switch to OFF.

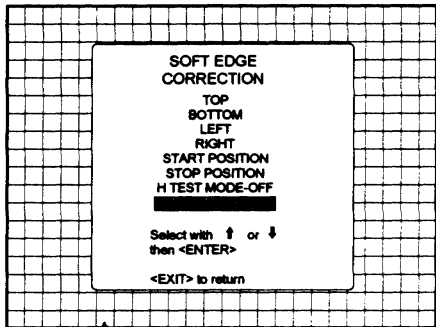

338h

ENTER toggles between V test mode OFF and ON.

EXIT returns to the random access adjustment mode main menu.

ADJUST returns to operational mode.

The test image is projected on the normal image. The start (stop) position is determined by the blanking controls. The blanking adjustment is also the image border for the begin (end) position of the soft edge area. Adjust the blanking for a normal video image.

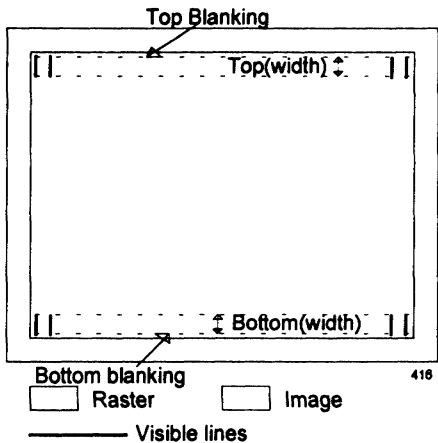

Top soft edge area adjustment

Highlight *TOP* with the arrow keys and press **ENTER**.

The normal image, superimposed with the test pattern will be displayed.

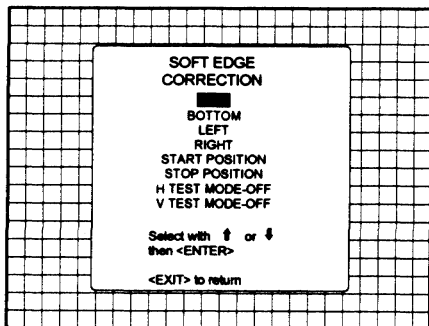

330a

ENTER displays the normal image superimposed with the internal generated test signal.

EXIT returns to the random access adjustment mode main menu.

ADJUST returns to operational mode.

Adjust the top soft edge area width by changing the length of the internal generated lines with the arrow keys.

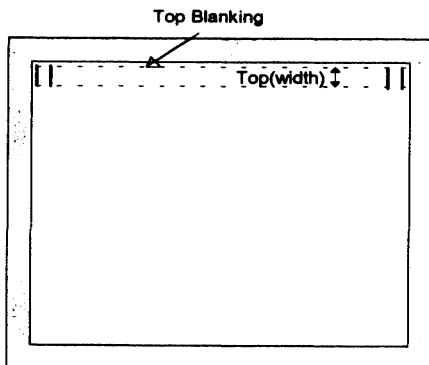

410a

ENTER returns to the soft edge correction menu.

Bottom soft edge area adjustment

Highlight *BOTTOM* with the arrow keys and press **ENTER**.

The normal image, superimposed with the test pattern will be displayed.

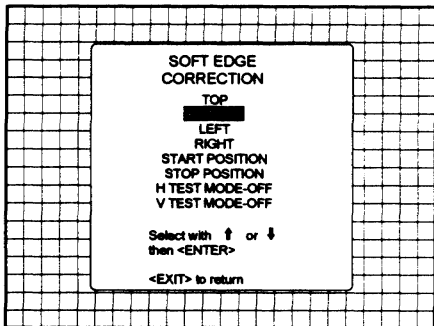

330b

ENTER displays the normal image superimposed with the internal generated test signal.

EXIT returns to the random access adjustment mode main menu.

ADJUST returns to operational mode.

Adjust the bottom soft edge area width by changing the length of the internal generated lines with the arrow keys.

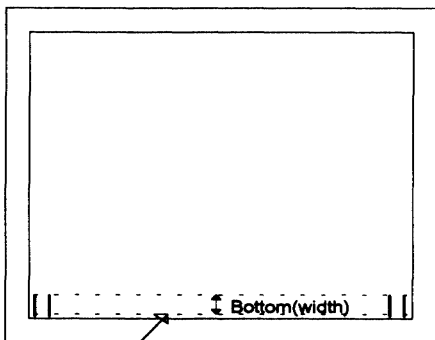

Bottom blanking

410b

ENTER returns to the soft edge correction menu.

Contrast modulation

Today multi-screens are very popular for many applications e.g. simulation business. In this installations, the goal is to obtain a continuous matched image, forming one homogeneous view. The viewer wants to see an overall light output uniformity.

The laws of physics applied to projection optics dictates that the center of the projected image will be brighter than the corners, this phenomenon is normally referred to as 'corner fall off'. Secondly, due to the normal off-axis projection of the red and blue images, CRT projection displays a phenomenon referred to as 'color shift', whereby one side of the screen is redish an the other blueish.

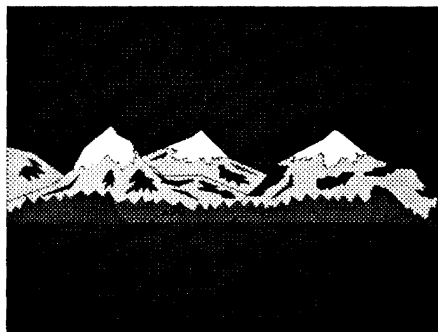

Picture without
contrast modulation

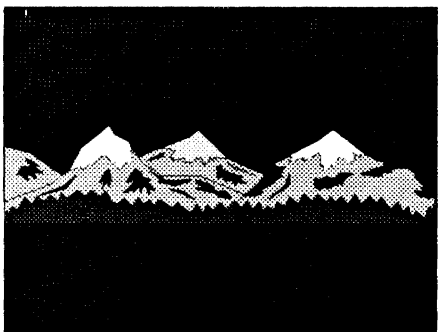

Picture with
contrast modulation

Basic concept

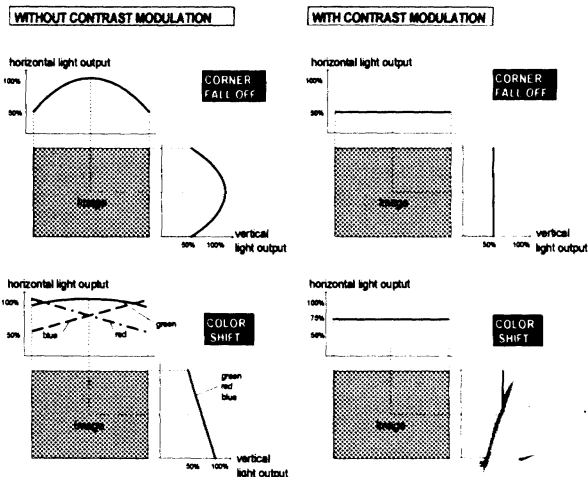

Adjustment procedure :

Start up the adjustment mode by pressing **ADJUST** (see also chapter 'Start up of the adjustment mode')

Highlight *Random access* with the arrow keys and press **ENTER** to start up the random access adjustment mode (see also chapter Random access adjustment mode). The *random access adjustment mode main menu* will be displayed.

When the *contrast modulation option* is installed, the projector automatically detects this option and displays the selection (activation) line in the random access adjustment mode main menu.

Highlight **CONTR. MODULATION** with the arrow keys and press **ENTER** to select.

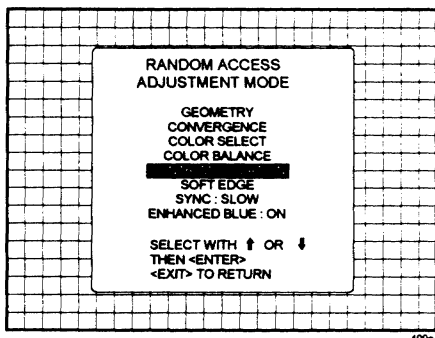

Note : An external generated white image will be useful during the adjustment.

Note : be sure the horizontal phase is correctly adjusted. The image must be centered on the raster with the horizontal phase adjustment, otherwise it is not possible to adjust the contrast modulation correctly.

ENTER selects the contrast modulation menu.
EXIT returns to the Path selection menu.
ADJUST returns to operational mode.

The first 3 adjustments (horizontal red, green, blue) are used for horizontal light equalisation for the three specific colors separately. This compensates the error due to the different horizontal position of the picture tubes. One side of the image is reddish and the other side is blueish. This phenomenon is called *Color shift*.

The *VERTICAL* adjustment affects the three colors at the same time and corrects the vertical error in light output due to the projection angle (10.5 degrees).

Left-right (horizontally) and top-bottom (vertically) adjustments improves the 'hot spot' in the center of the screen.

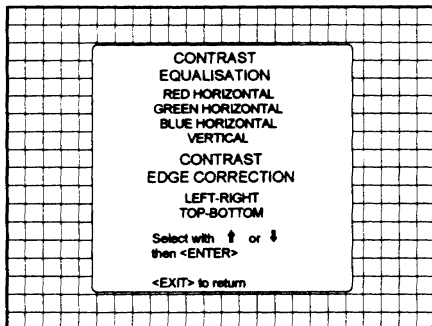

Contrast equalisation ('Color Shift')

Highlight *RED HORIZONTAL* with the arrow keys and press **ENTER**. Only a red image is displayed. Use the arrow keys to equalise the light output on the left and right side of the image. The best result is obtain on a white image by looking on the left and the right side until both or equal, or by using a very sensitive light meter.

ENTER returns to the contrast modulation menu.

Repeat this adjustment for green and blue. by selecting first Green horizontal and than Blue horizontal.

Remark : When the end of adjustment range is reached for red and blue, the green image will be displayed too, to give you the message 'end of adjustment range'. The green image stays active until a new selection is made.

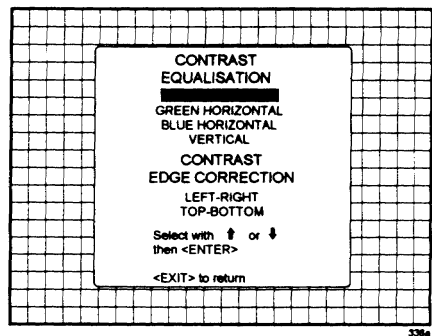

ENTER displays the red image.
EXIT returns to the Random access adjustment mode main menu
ADJUST returns to operational mode.

Highlight **VERTICAL** with the arrow keys and press **ENTER**. This adjustment is done for on all three colors at the same time.

Use the arrow keys to equalise the vertical light output and press **ENTER** to continue.

The best result is obtain on a white image by looking on the top and the bottom side until both or equal, or by using a very sensitive light meter.

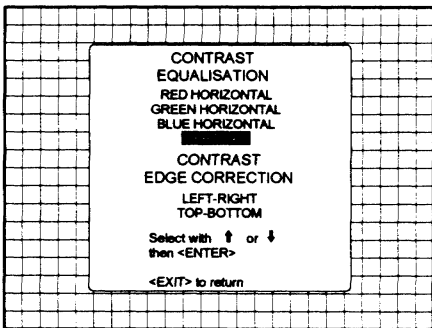

ENTER selects the Vertical contrast equalisation option.
EXIT returns to the Random access adjustment mode main menu.
ADJUST returns to operational mode.

Contrast edge correction ('hot spot')

Highlight **LEFT-RIGHT** with the arrow keys and press **ENTER** to start the horizontal 'hot spot' correction in the center of the screen. Adjust with the arrow keys for the same light output in the corners as in the center of the image.

This left-right adjustment must be done in combination with the top-bottom adjustment as both adjustments influence each other.

Note : these adjustments will reduce the total light output, so do not over adjust.

Hint : A bar scale of 10 - 15 for both adjustments gives a good result.

Press **ENTER** to return to the contrast modulation menu.

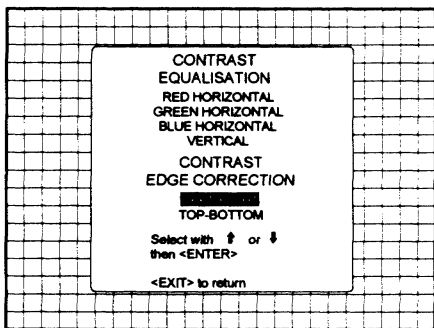

ENTER starts the left-right contrast edge correction.
EXIT returns to the Random Access adjustment main menu.
ADJUST returns to operational mode.

Highlight *TOP-BOTTOM* with the arrow keys and press **ENTER** to start the vertical *'hot spot'* correction in the center of the screen. Adjust with the arrow keys for the same light output in the corners as in the center of the image.

This top-bottom adjustment must be done in combination with the left-right adjustments as both adjustments influence each other.

Note : these adjustments will reduce the total light output, so do not over adjust.

Hint : A bar scale of 10 - 15 for both adjustments gives a good result.

Press **ENTER** to return to the contrast modulation menu.

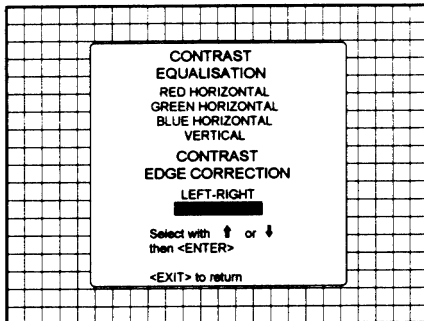

ENTER starts the top-bottom contrast edge correction.

EXIT returns to the Random Access adjustment main menu.

ADJUST returns to operational mode.

Battery replacement in the RCU.

Remove the battery cover on the backside of the remote control by pushing the indicated handle a little to the bottom of the RCU. Lift up the top side of the cover at the same time (fig. 1).

Remove the battery from the compartment and disconnect the contact plate (fig. 2). Connect a new 9 V battery (type Block E, e.g. 6F22S or equivalent) to the contact plate. Insert the battery back into the compartment and put the cover back.

Attention : when a new battery is installed, the projector address must be reprogrammed before using the RCU.

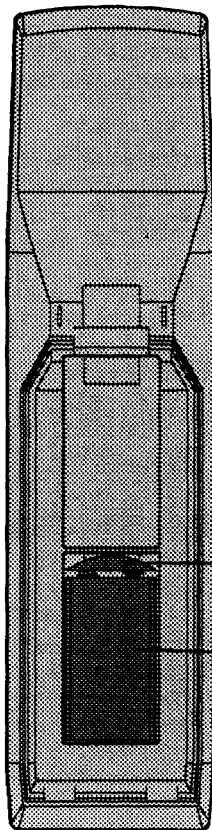

Contact plate

Battery

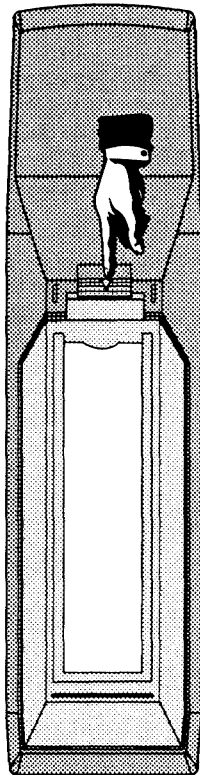

fig.1

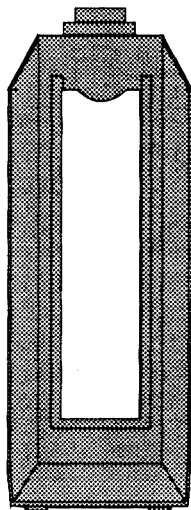

fig.2

310a DRW

Adjustment Blocks

As the BARCOGRAPHICS 801 is digitally controlled, all geometry and convergence adjustments are stored in the projector's memory as numeric values. These numeric values are used to control digital potentiometers which in turn, control the projector. Each source connected to the projector has a unique set of adjustment data which is automatically downloaded into the projector's digital potentiometers as the source is selected. This set of adjustment data is referred to as an "adjustment block".

An adjustment table is automatically created for a source when the source is first connected to the projector and the adjust mode is entered. If other sources have already been connected to the projector and geometry and convergence adjustments have been performed on these sources, the projector will use Linear Digital Interpolation to create a new block for the new source. This block will provide an initial set of adjustments for the new source that have been calculated by the projector from "previous experience".

The projector's memory has the capacity to store 32 adjustment blocks. The adjustment block consists of two parts, the block header and the data representing the convergence and geometry adjustments of the source the block corresponds to. The block header contains the basic characteristics of the source and the projector configuration used to display the source.

<i>Block Header</i>	<i>example of block header</i>
Block number	01
Source number	01
Horizontal frequency	15.6 kHz
Vertical frequency	50 Hz
Input type	video
Scan inversion switch configuration	front/ceiling

The data representing the geometry and convergence adjustments for the source follows the block header.

Source numbers 90 - 99

Source numbers 90 - 99 do not correspond to physical inputs to the projector or RCVDS800. They are used to assign an additional adjustment block to a source. This additional adjustment block may contain different geometry and convergence settings, sync fast/slow positions and enhanced blue on/off settings. The relationship between source numbers 0 - 9 and 90 - 99 (projector with RCVDS) or 1 - 5 and 91 - 95 (stand-alone projector) is shown in the diagram below.

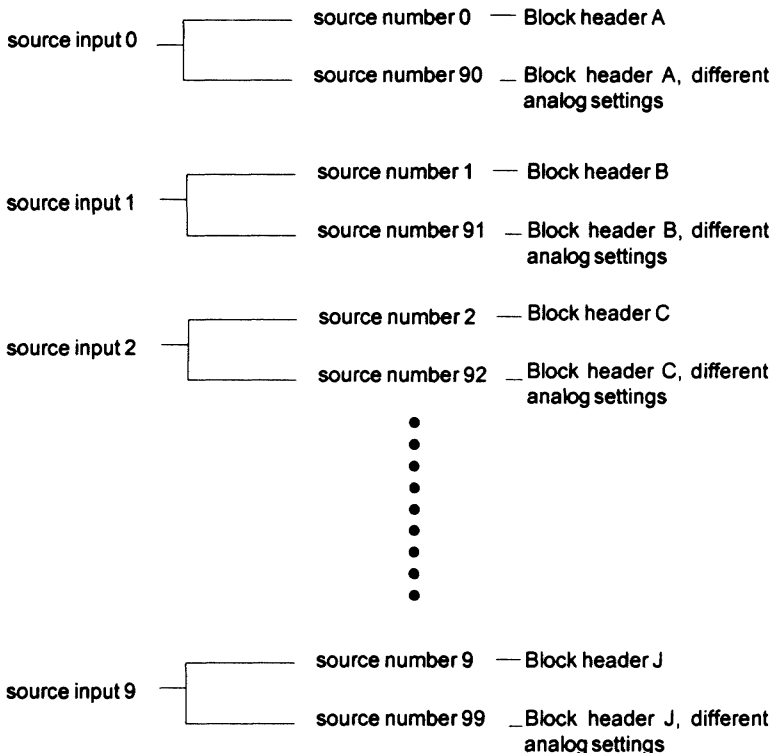

The alternate adjustment block for sources 0 - 9 (projector with RCVDS) or 1 - 5 (stand-alone projector) is activated by selecting the corresponding source number 0 - 9 (projector with RCVDS) or 1 - 5 (stand-alone projector). Once this source number is selected, the alternate block of adjustment data is in use and may be modified via the adjust mode of the projector. The alternate adjustment block is automatically stored.

Follow the steps below to create a second adjustment block for a source between 0 and 9.

1. Select the source between 0 and 9 that the second adjustment block is to be created for.
2. Select the corresponding source number between 90 and 99. The adjustment block for the source number between 0 and 9 is copied to the corresponding source number between 90 and 99.
3. Enter the adjust mode and make any desired changes (geometry, convergence, sync fast/slow, enhanced blue on/off) to the second adjustment block.
4. Exit the adjust mode.

Note : the above also applies to source number 1 - 5 and 91 - 95 of a stand alone projector (no RCVDS)

MATERIAL SAFETY DATA SHEET

Form Approved
Bureau Budget No. 45-R0338

MANUFACTURER'S NAME AND FSCM (Federal Supply Code for Manufacturer's)
BARCO n.v.

EMERGENCY PHONE NO.
32-56-368211

ADDRESS (Number, Street, City, State, and ZIP Code)

Noordlaan 5 B-8520 KUURNE

SECTION I

CHEMICAL NAME AND SYNONYMS
Ethylenglycol & water

TRADE NAME AND SYNONYMS
Cooling liquid 512333

CHEMICAL FAMILY
Polyalcohols

FORMULA
 $C_2H_4O_2 + H_2O$

FEDERAL STOCK NUMBER (FSN)

GROSS WEIGHT (LBS)

OUTSIDE PACKAGE DIMENSIONS

MIL-STD-1341/NATIONAL FIRE PROTECTION ASSOCIATION STD 704M SIGNAL

FLAMMABILITY.....

HEALTH.....

REACTIVITY.....

SPECIFIC HAZARD.....

SECTION II HAZARDOUS INGREDIENTS

PAINTS, PRESERVATIVES, AND SOLVENTS	%	TRESHOLD LIMIT VALUE (Units)	ALLOYS AND METALLIC COATINGS	%	TRESHOLD LIMIT VALUE (Units)
PIGMENTS	/		BASE METAL	/	
CATALYST	/		ALLOYS	/	
VEHICLE	/		METALLIC COATINGS	/	
SOLVENTS	/		FILLER METAL PLUS COATING OR CORE FLUX	/	
ADDITIVES	/		OTHERS	/	
OTHERS	/				
HAZARDOUS MIXTURES OF OTHER LIQUIDS, SOLIDS, OR GASES				%	TRESHOLD LIMIT VALUE (Units)

SECTION III PHYSICAL DATA

BOILING POINTS (°C)	106°C	SPECIFIC GRAVITY (H₂O = 1)	1.08
VAPOR PRESSURE (mm Hg)	3.75mm Hg	PERCENT VOLATILE BY VOLUME (%)	/
VAPOR DENSITY (AIR = 1)	2.1	EVAPORATION RATE (..... = 1)	/
SOLUBILITY IN WATER	∞		
APPEARANCE AND ODOR			

SECTION IV FIRE AND EXPLOSION HAZARD DATA

FLASH POINT (Method used)	FLAMMABLE LIMITS	LOWER EXPLOSIVE LIMIT	UPPER EXPLOSIVE LIMIT
EXTINGUISHING MEDIA			
SPECIAL FIRE FIGHTING PROCEDURES			
UNUSUAL FIRE AND EXPLOSION HAZARDS			

SECTION V HEALTH HAZARD DATA	TRESHOLD LIMIT VALUE <i>100ppm</i>		
	EFFECTS OF OVEREXPOSURE		
	EMERGENCY AND FIRST AID PROCEDURES		
SECTION VI REACTIVITY DATA	STABILITY	UNSTABLE	CONDITIONS TO AVOID
		STABLE	X
	INCOMPATIBILITY (Materials to avoid)		
	HAZARDOUS DECOMPOSITION PRODUCTS		
SECTION VII SPILL OR LEAK PROCEDURES	HAZARDOUS POLYMERIZATION	MAY OCCUR	X
		WILL NOT OCCUR	
	CONDITIONS TO AVOID		
	STEPS TO BE TAKEN IN CASE MATERIAL IS RELEASED OR SPILLED		
SECTION VIII - SPECIAL PROTECTION INFORMATION	RESPIRATORY PROTECTION (Specific type)		
	VENTILATION	LOCAL EXHAUST	SPECIAL
		MECHANICAL (General)	OTHER
	PROTECTIVE GLOVES		EYE PROTECTION
SECTION IX SPECIAL PRECAUTIONS	OTHER PROTECTIVE EQUIPMENT		
	PRECAUTIONS TO BE TAKEN IN HANDLING AND STORING		
	<i>Harmful if swallowed</i>		
	<i>Keep out of the reach of children</i>		
OTHER PRECAUTIONS			
<i>To avoid from oxidants</i>			

THE INFORMATION CONTAINED HEREIN IS BASED ON DATA CONSIDERED ACCURATE. HOWEVER, NO WARRANTY IS EXPRESSED OR IMPLIED REGARDING THE ACCURACY OF THE DATA, OR THE RESULTS TO BE OBTAINED FROM THE USE THEREOF. VENDOR ASSUMES NO RESPONSIBILITY FOR INJURY TO VENDEE OR THIRD PERSONS PROXIMATELY CAUSED BY THE MATERIAL IF REASONABLE SAFETY PROCEDURES ARE NOT ADHERED TO AS STIPULATED IN THE DATA SHEET. ADDITIONALLY, VENDOR ASSUMES NO RESPONSIBILITY FOR INJURY TO VENDEE OR THIRD PERSONS PROXIMATELY CAUSED BY ABNORMAL USE OF THE MATERIAL EVEN REASONABLE SAFETY PROCEDURES ARE FOLLOWED. FURTHERMORE, VENDEE ASSUMES THE RISK IN HIS USE OF THE MATERIAL.

Insert card for RCU

BARCO PROJECTORS

BV701
BD701

BD5000 (use the non-filled
side up)

RCU	
INPUT SOURCES	
PROJECTOR	
1	Video
2	S-Video
3	RGsB/RGB-S
4	RGsB/RGB3S
5	Component
6	Component+3L

RCU	
INPUT SOURCES	
PROJECTOR	
1	
2	
3	
4	
5	
6	
7	

INPUT SOURCES	
RCVDS	
1	
2	
3	
5	
6	
7	
8	
9	
10	

INPUT SOURCES	
RCVDS	
1	
2	
3	
5	
6	
7	
8	
9	
10	

99 75045

99 75045



BARCO PROJECTORS

BG801-BD801
RG801-RD801
BG1200-BG1208
BD1101

* Optional

BV1200HD

* Standard

BV1600HD

* Not Available

RCU	
INPUT SOURCES	
PROJECTOR	
1	Video
2	S-Video
3	RGB Analog
4	RGsB
5	RGB-S
6	RGsB*
7	RGB-3S*

RCU	
INPUT SOURCES	
RCVDS	
1	
2	
3	
5	
6	
7	
8	
9	
10	

INPUT SOURCES	
RCVDS	
1	
2	
3	
5	
6	
7	
8	
9	
10	

11	
12	
13	
14	
15	
16	
17	
18	
19	
20	

99 75046

99 75046



BARCO nv/Projection Systems
Noordlaan 5
B-8520 Kuurne
Belgium

Printed in Belgium